

*Building the pre-eminent vertically integrated **Lithium** business in Ontario, Canada*

# **PRELIMINARY ECONOMIC ASSESSMENT DELIVERS STRONG ECONOMICS & MINING LEASE GRANTED FOR SEYMOUR**

## **Cautionary Statement**

The Preliminary Economic Assessment (PEA) referred to in this announcement is a preliminary technical and economic study of the potential viability of developing the Seymour Lithium Project, Root Lithium Project and Lithium Conversion Facility by developing both Seymour and Root mines, constructing a concentrate processing facility at Seymour and constructing a lithium conversion plant at Thunder Bay. The PEA referred to in this announcement is based on lower-level technical and preliminary economic assessments and is insufficient to support estimation of Ore Reserves or to provide assurance of an economic development case at this stage, or certainty that the conclusions of the PEA will be realised.

Approximately +/-70.0% of the Life-of-Mine production is in the Indicated Mineral Resource category and +/-30.0% is in the Inferred Mineral Resource Category. The Company has concluded it has reasonable grounds for disclosing a Production Target, given that the PEA assumes that in the first 12 years of the 15 years of operation, the majority of each year's production (with the exception of year 5) is derived from the Indicated Resource category. The inferred Mineral Resource is not the determining factor in determining the viability of the Seymour Lithium Project, Root Lithium Project and Lithium Conversion Facility.

There is a low level of geological confidence associated with Inferred Mineral Resources and there is no certainty that further exploration work will result in the determination of further Measured or Indicated Mineral Resources or that the Production Target or preliminary economic assessment will be realised. The PEA is based on the material assumptions outlined elsewhere in this announcement. These include assumptions about the availability of funding. While the Company considers all the material assumptions to be based on reasonable grounds, there is no certainty that they will prove to be correct or that the range of outcomes indicated by the PEA will be achieved.

To achieve the potential mine development outcomes indicated in the PEA, funding in the order of CAD\$282 million is required for Stage 1, CAD\$ 1,064 million is required for Stage 2 and a further CAD\$467 million is required for Stage 3, representing a total of \$1,821 million that will likely be required to fund the three stages considered in this study. Investors should note that there is no certainty that the Company will be able to raise funding when needed, however the Company has concluded it has a reasonable basis for providing the forward-looking statements included in this announcement and believes that it has a "reasonable basis" to expect it will be able to fund the development of the Project based on the staged funding strategy which involves a combination of strategic partnering and strategic debt, as well as equity financing and funding from available government infrastructure funds. It is also possible that such funding may only be available on terms that may be dilutive to, or otherwise affect the value of the Company's existing shares. It is also possible that the Company could pursue other strategies to provide alternative funding options. Given the uncertainties involved, investors should not make any investment decisions based solely on the results of the PEA. While the Company believes it has a reasonable basis for funding the three stages of development, if insufficient funding precluded the development of the Stage 2 Lithium Hydroxide Conversion facility, the Company believes it has a reasonable basis to raise financing to support the development of Stages 1 and 3 only.

## HIGHLIGHTS

- Mining Lease granted over proposed Seymour mine construction area for a term of 21 years
- Combined mine and concentrator development delivers **NPV \$1,189M CAD (USD\$894M)**
- Excellent economics confirmed in the PEA for both project development options with the potential to become the first lithium concentrates and chemical producer in Ontario
- Definitive Feasibility Study (DFS) for Seymour now underway, targeting Financial Investment decision (FID) ahead of planned construction activities in 2024
- Further resource growth expected in calendar year 2024

## MINE AND CONCENTRATOR DASHBOARD

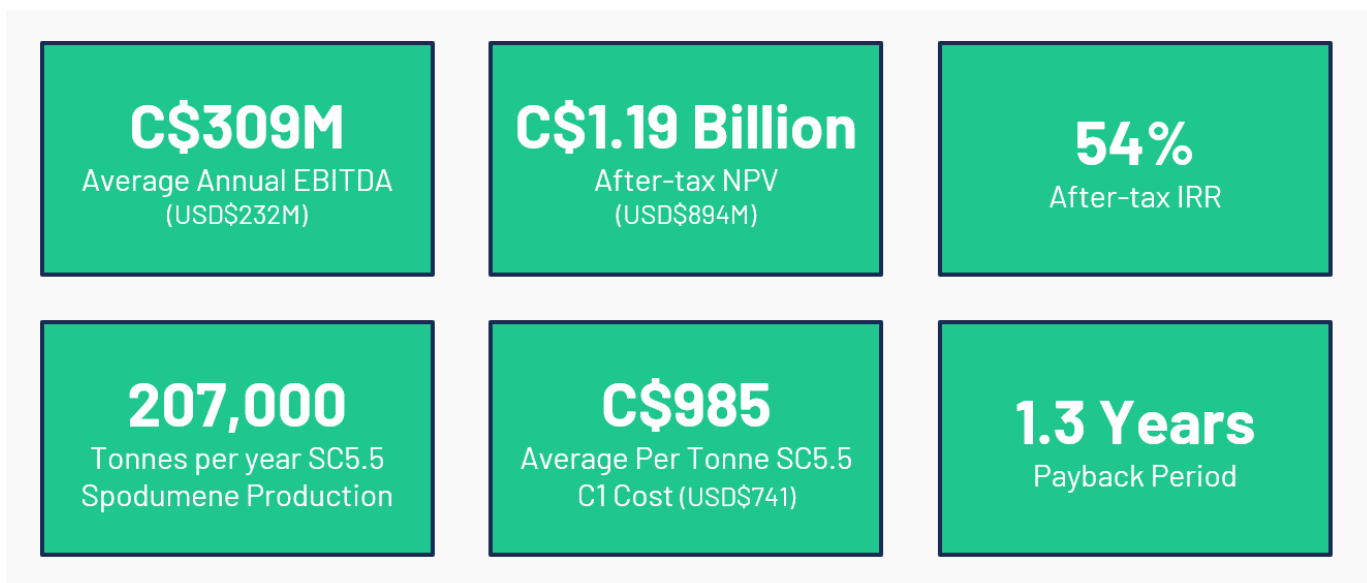

## PRELIMINARY ECONOMIC ASSESSMENT (PEA) SUMMARY

- **PEA considers two development options:**
  - Mine and concentrator development (Seymour and Root) producing saleable SC5.5 concentrates, and
  - Integrated project with construction of a converter to produce battery grade Lithium hydroxide from Seymour, Root and other spodumene concentrates
- **Combined Seymour & Root Mine and Spodumene Concentrators**
  - Combined open pit mining strategies culminating in 15 years of mine production, with phased capex for two mines and concentrators.
  - LOM average concentrate production of **207ktpa at 5.5% Li<sub>2</sub>O**
  - Initial start-up capex of **CAD \$216M (USD \$162M)**
  - Second phase capex of **CAD \$467M (USD \$351)**

- Overall contingency included **CAD \$77M (USD \$58M)**
- After-tax NPV of **CAD \$1,189M (USD \$894M)**, IRR of **54%**, total LOM revenue of **CAD \$7,958M (USD \$5,984M)**
- **Initial Capex to NPV ratio 5.5:1**
- 25% offtake committed from Seymour to LGES for first 5 years of production
  
- **Integrated Lithium Project – Mine, Concentrators & Chemical Conversion Facility**
  - Mine concentrator development feeding SC5.5% to conversion facility located in Thunder Bay, Ontario
  - Average Lithium Hydroxide Monohydrate production of 24,400tpa
  - Start-up capex of **CAD \$1,064M (USD \$800M)**
  - Contingency included **CAD \$210M (USD \$158M)**
  - After-tax NPV of **CAD \$1,506M (US \$1,132M)**, IRR of **27%**, total LOM revenue of **CAD \$14,230M (US \$10,699M)**
  
- **Strategic participation and government funding options**
  - Strategic funding options currently being assessed for mine and concentrators, along with potential operators for Lithium Conversion facility
  - Strategic Innovation Fund (SIF) application lodged and assessment ongoing
  - Further initiatives announced under Critical Minerals Infrastructure Fund (CMIF) recently for up to \$1.5B for critical minerals projects
  - Potential Critical minerals processing equipment tax rebate at 30%
  
- **Further potential for production expansion and increases in Mineral Resources underway, with a substantial drilling planned for 2024**

Green Technology Metals Limited (**ASX: GT1**)(**GT1 or the Company**), a Canadian-focused multi-asset lithium business, is pleased to announce the completion of its Preliminary Economic Assessment (**PEA**) that features vertically integrated mines, concentrators and a Lithium Hydroxide Conversion facility (**Converter or Integrated Project**). The Project has compelling projected economics due to attractive capital and operating costs, short transportation distances, minimal royalties and low corporate income taxes.

***“We are pleased to deliver our PEA which initially includes the Mines and Concentrators in North-Western Ontario, confirming a strong NPV and robust project delivery strategy with low capital hurdles to get GT1 first into production within the province of Ontario.***

***The second part of the PEA includes the conversion of Lithium concentrates to Lithium chemicals which are currently unavailable in North America and will play a critical role in closing the supply chain from mine to electric vehicle, all Ontario Made”.***

***The success of GT1’s Strategy includes collaboration between Indigenous Partners, Communities, Government, Industry, and all Stakeholders. Working together, the actions in this strategy will build a stronger, more resilient business and promote local communities”.***

-GT1 Chief Executive Officer, Luke Cox

## Executive Summary

The comprehensive PEA has been conducted by a team of highly experienced and reputable industry personnel both within GT1 and independent consultants from Canada and Australia. This includes contributions from Entech Mining, Primero Group, Nordmin Engineering, and Englobe. The PEA draws on the Mineral Resource Estimates of the Seymour Lithium Project, amounting to 10.3 million metric tons at 1.03% Li<sub>2</sub>O (comprised of 6.1 Mt at 1.25% Li<sub>2</sub>O indicated and 4.2 at 0.7% Li<sub>2</sub>O inferred) and the Root Lithium Project, with a Mineral Resource Estimate of 14.6 million metric tons at 1.21% comprised of 9.4Mt @ 1.30% Li<sub>2</sub>O Indicated and 5.2Mt at 1.03% Li<sub>2</sub>O Inferred).

The PEA validates the company's potential to emerge as a large-scale, cost-effective producer of lithium concentrates and chemicals, emphasizing environmentally sustainable production of SC5.5 spodumene concentrate and Lithium Hydroxide (LiOH). The favorable location in Northwestern Ontario, a tier-one global mining jurisdiction for lithium exploration and development, with proximity to existing infrastructure, mid and downstream suppliers in the electric vehicle supply chain and major high-tech population centers yields considerable cost savings and a competitive edge in the market.

The PEA analysis considers two project development options. Both options emphasize the generation of substantial net cash flows throughout the Life of Mine (LOM). These cash flows will be directed towards funding subsequent stages of the project. The company firmly believes in the continual growth of the mineral resources in the coming years, driven by both organic and inorganic expansion. This growth is anticipated to secure additional years of feed to both concentrators and the proposed Lithium Hydroxide conversion facility, primarily sourced from GT1's proprietary mines extending the projects lifespan.

The first option involves Spodumene Production from the Seymour and Root mines and concentrators without the converter, covering 15 years of mine/concentrate feed exclusively from the 100% owned projects. The second option encompasses an integrated project of the mines, concentrators, and a Lithium Hydroxide Conversion facility. This option is currently designed for a 15-year Life of Mine (LOM) confined to the current Mineral Resource Estimates for both the Seymour and Root projects, which the company foresees significant expansion through ongoing exploration efforts in the upcoming years, in line with the resource growth attributed over the past 2 years.

GT1 is optimistic that the conversion facility has the potential to operate for an additional 10 years beyond the current scope of this PEA and that an extension to LOM will yield an improved NPV for the integrated project. This extended operational period would surpass the current resource estimates and potentially incorporate additional supply of SC5.5 feed from North American-based suppliers which GT1 remains actively engaged in discussions for this strategy.

Both options are independently feasible.

Additionally, this strategy is supported by local and provincial government bodies, along with strategic partners including the Thunder Bay Community Economic Development Commission (CEDC) who are actively committed to fostering economic opportunities for the city. This includes providing support for various lithium resource projects in the region and the establishment of a lithium hydroxide facility within the city. GT1 envisions that this development scenario will result in a surplus of feed from both new and existing mineral resources in the region surrounding the Converter, making it available as a feedstock over the remaining 10-year period.

The financial projections used in the study rely on a weighted average spodumene concentrate price of US\$2,029/t SC5.5 FOB Thunder Bay drawing on the average price forecasts provided by Fastmarkets, a prominent price reporting agency in the lithium sector.

The projects have been strategically divided into three distinct stages of development designed to lower the capital barrier for entering production. This not only positions the Company as a producer but also establishes project cash flow, aligning with GT1's overarching strategy of being the 'first' producer in Ontario'. Moreover, this strategy facilitates project assessment and enables strategic partners to engage in the comprehensive supply chain of lithium chemical supply developed by GT1 in Ontario

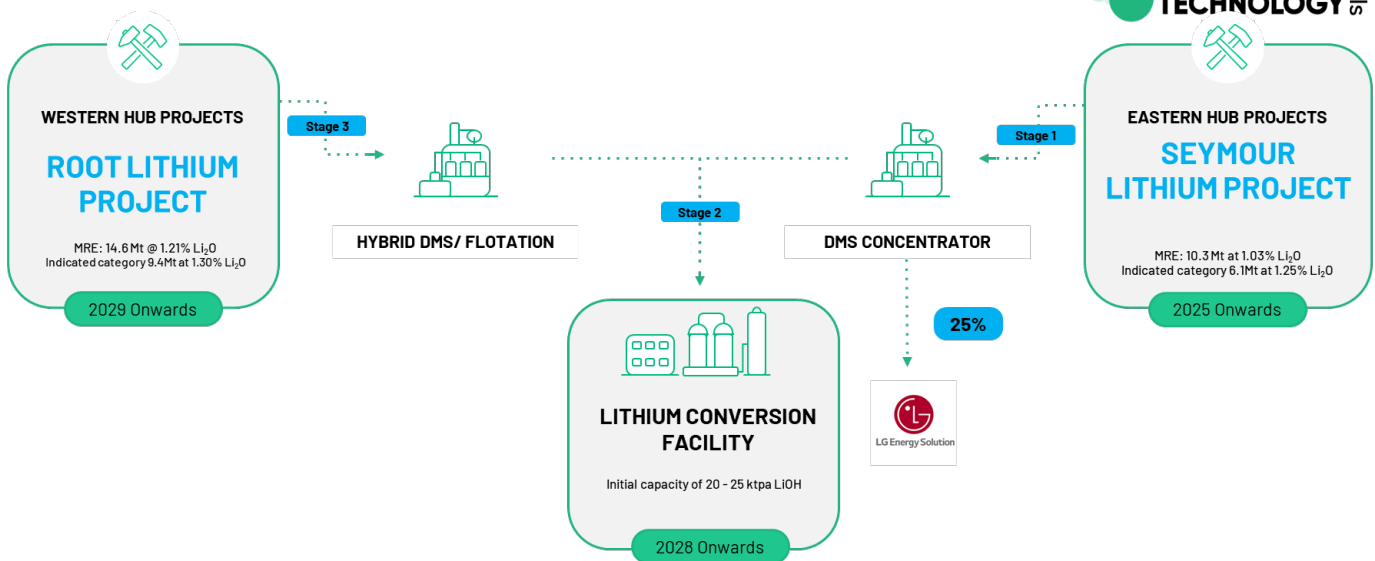

**Figure 1: 3-stage vertically integrated strategy**

Following the completion of the vertically Integrated Scoping Study, the Company will initiate three separate studies, each aligned with a specific project stand and individual workstream to enable differing development timelines as required by the overall strategy. At a corporate level the 3 projects will transition into separate business lines, enabling investment into to each of the businesses separately.

**Stage 1 - Definitive Feasibility Study: Seymour Mine and Concentrator - Q2 2024**

**Stage 2 - Preliminary Feasibility Study: Lithium Conversion Facility - Q4 2024**

**Stage 3 - Preliminary Feasibility Study: Root Mine and Concentrator - Q2 2025**

## ECONOMIC ANALYSIS

A detailed financial model and discounted quarterly cash flow (DCF) has been developed to complete the economic assessment of the project and is based on current (Q4 2023) price projections and cost estimates.

**Option 1: Mine and Concentrators** evaluates the economics of Spodumene production from both the Seymour Project and the Root Project over their respective mine lives, without the Converter. It includes all capital and operating costs for mining and concentrator operations and based on selling SC5.5 to external parties.

**Option 2: Integrated Project** evaluates the economics of the Integrated project that includes the mines, concentrators and Lithium Hydroxide facility, over a 15-year mine life. This option confined to the current Mineral Resource Estimates for both the Seymour and Root projects that the company foresees significant expansion through ongoing exploration efforts in the upcoming years. The study incorporates a flat CAD:USD exchange rate of 0.75 for the PEA.

Base Case Financial Results	Unit of Measure	Option 1 Spodumene Production	Option 2 Integrated
Project Length	Y	15	15
After-Tax NPV @ 8%	CAD (M)	1,189	1,506
After-Tax IRR	%	54	27
After-Tax Payback Period	Y	1.3	3.3

**Table 1: Financial Results**

Operating Parameters Mine and Concentrator		Units	Total
Mill feed mined (inc prestrip)	<b>Mt</b>		20.4
Waste mined (inc prestrip)	<b>Mt</b>		451.7
Total material mined (inc prestrip)	<b>Mt</b>		472.1
Mine life	<b>years</b>		15
Average strip ratio (waste:ore) excluding pre-strip	<b>(w:o)</b>		21.1
Seymour	<b>(w:o)</b>		17.3
Root	<b>(w:o)</b>		23.2
LOM average annual ore production	<b>Mtpa</b>		1.46
LOM Average Li <sub>2</sub> O grade (undiluted)	<b>% Li<sub>2</sub>O</b>		1.09
Concentrator Throughput (maximum) – Seymour	<b>Mt</b>		1.5
Concentrator Throughput (maximum) – Root	<b>Mt</b>		1.5
Concentrator Ramp Up – Seymour	<b>mths</b>		6
Concentrator Ramp Up – Root	<b>mths</b>		9
Spodumene Concentrate Produced	<b>Mt</b>		2.9
Spodumene Concentrate Grade	<b>%</b>		5.5
Average Li <sub>2</sub> O recovery (65% Seymour & 75% Root)	<b>%</b>		71.6
Conversion Facility			
LiOH Converter Throughput	<b>kt</b>		180
LiOH Converter Ramp Up	<b>mths</b>		24
LiOH:H <sub>2</sub> O Recovery	<b>%</b>		92
Average annual (LiOH) Production (dry)	<b>kt</b>		24.4

**Table 2: Operating Parameters**

Operating and Capital Costs	Mining and Concentrators CAD million	Integrated Project CAD million
Gross revenues (SC5.5 and LiOH)	7,958	14,230
Royalties and Transportation	-858	-434
<b>Net revenues</b>	<b>7,100</b>	<b>13,796</b>
Raw Materials		-2,208
Operational Expenditure	-2,770	-4,300
<b>EBITDA</b>	<b>4,331</b>	<b>7,288</b>
Capital expenditure (pre-production)	-749	-1,812
Sustaining and deferred capital	-137	-154
Gross profit before tax (EBT)	<b>3,445</b>	<b>5,322</b>
Tax	-896	-1,384
<b>Net Profit After Tax (NPAT)</b>	<b>2,549</b>	<b>3,938</b>

**Table 3: Totals - Operating and Capital Costs**

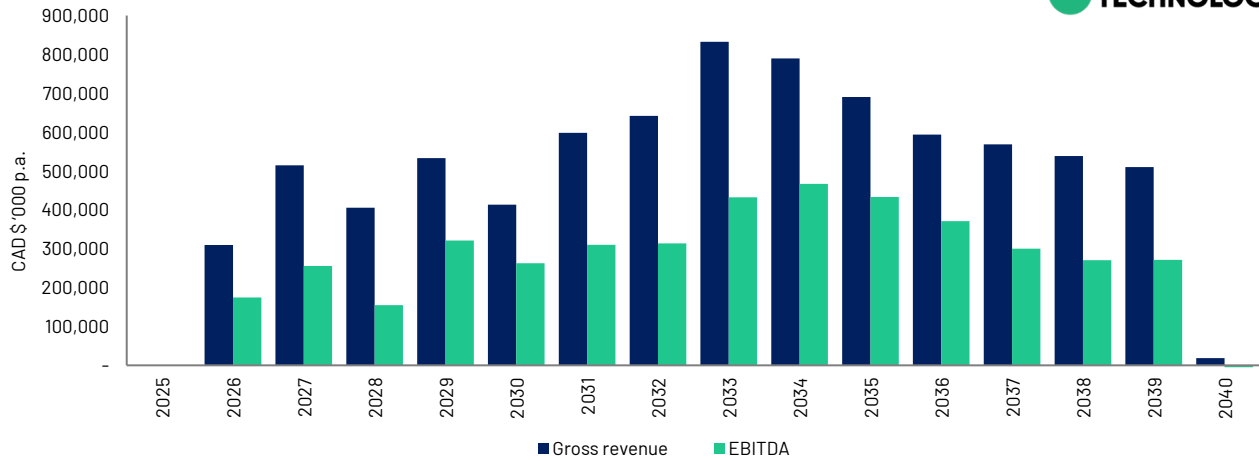

Figure 2: Mine & Concentrator - Gross Revenue / EBITDA

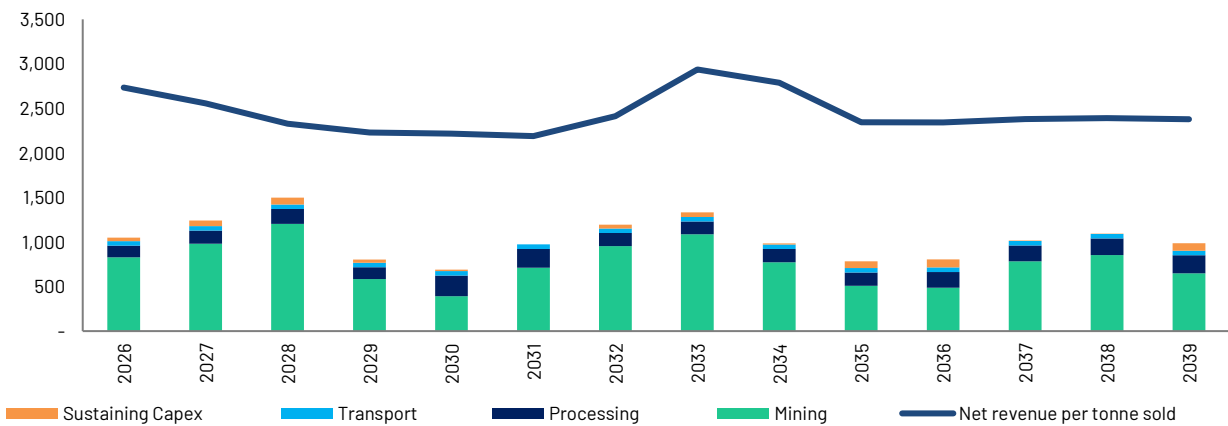

Figure 3: Mine & Concentrator - Unit Revenue/Operating cost/tonne

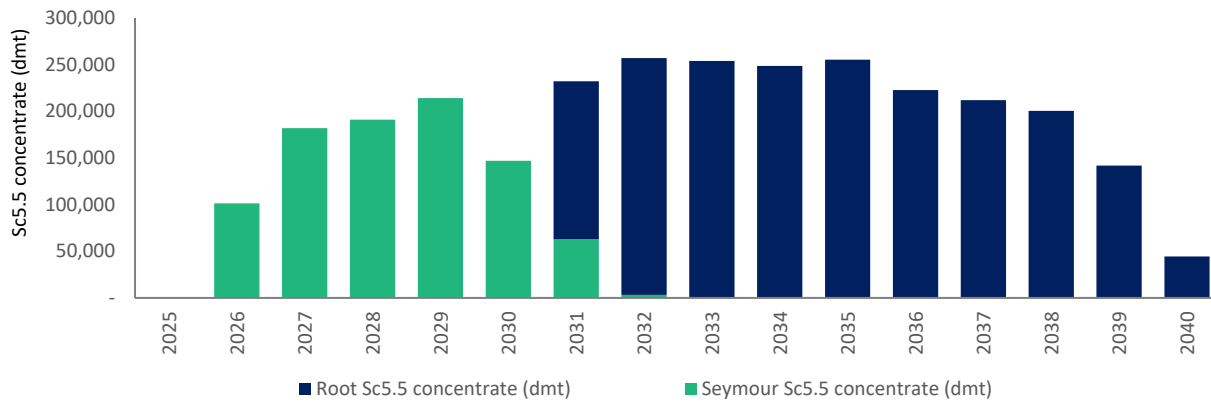

Figure 4: Annual Concentrator Production Sc5.5 (dmt)

## CAPITAL EXPENDITURE

Seymour and Root Projects		Seymour	Root
Area		Capital (CAD)	Capital (CAD)
Site General		21M	37M
Mining		1M	1M
Processing Plant		69M	138M
Site Infrastructure		23M	43M
Camp		7M	7M
Storage Facilities		24M	25M
Seymour Concentrator Indirects		38M	70M
Owners Cost		5M	9M
<b>Sub-total</b>		<b>188M</b>	<b>329M</b>
Contingency (15%)		28M	49M
<b>Total inc Contingency</b>		<b>216M</b>	<b>378M</b>
Mining Pre-Production		53M	79M
Plant and Admin Pre-Production		13M	10M
<b>Total inc Pre-Production and Contingency</b>		<b>282M</b>	<b>467M</b>

Contingency is set at 15%.

**Table 4: Seymour and Root Projects**

Conversion Facility Area	Capital (CAD)
LiOH Plant	607M
Site Infrastructure	27M
Tailings Disposal	0.4M
Lithium Hydroxide Indirects	168M
8100 - Owners Cost	38M
<b>Sub-total</b>	<b>840M</b>
Contingency (25%)	210M
<b>Total inc Contingency</b>	<b>1,050M</b>
Plant Pre-Production	13M
<b>Total inc Pre-Production</b>	<b>1,064M</b>

Contingency is calculated at 25% and is based on the accuracy of study design and pricing.

**Table 5: Conversion Facility**



## FINANCING<sup>1</sup>

### Stage 1 – Seymour Mine

Initial capital will be staged over an 18-month development timeframe and will be sourced through a number of different strategies to ensure procurement and construction milestones are met. The initial start-up capital for plant and processing infrastructure will be \$216M CAD which includes for 15% contingency.

There is substantial demand for long-term offtake in North America and it's the Company's strategic objective to maximise the value of this offtake to support a balanced capital structure and an alignment of interest between end-user partners and key financial stakeholders. The company intends to seek minority asset-level investment from strategic groups associated with the battery minerals supply chain in Ontario and surrounding jurisdictions and has commenced a number of confidential discussions in respect to this. A debt funding package will be structured to complement the asset-level investments with the co-operation of the selected strategic partners and their network of financiers. It is expected this will also allow the opportunity for government funding schemes to participate through the various infrastructure and critical minerals initiatives currently being offered by both Provincial and Federal Canadian government schemes, such as the Critical Minerals Infrastructure Fund (CMIF), Export Development Canada (EDC) and the Canadian Infrastructure Bank (CIB). The company has been in consistent contact with all three of these agencies and is currently assessing funding opportunities under application.

The financing structures currently being contemplated by the company include for asset level investment from strategic groups associated with the battery minerals supply chain in Ontario and surrounding jurisdictions. This will be complemented by sourced debt funding from these strategic groups that have the opportunity to provide club style debt, along with their asset level investment from foreign infrastructure banks and corporate financing groups. This will also allow the opportunity for government funding schemes to participate alongside as senior debt providers.

Pre-development costs including pre-strip for the Seymour mine will be CAD\$69M and will be funded from debt and equity sourced later through the development stage in mid-2025, prior to production commencement late that year. Pre-strip will enable the production to be ramped up to full production within the first 6 months of operation.

The chart below provides an indicative breakdown of the Company's financing strategy, noting this is preliminary in nature and each funding component may be higher or lower subject to the Board of Directors view of the risk and return trade-off for shareholders.

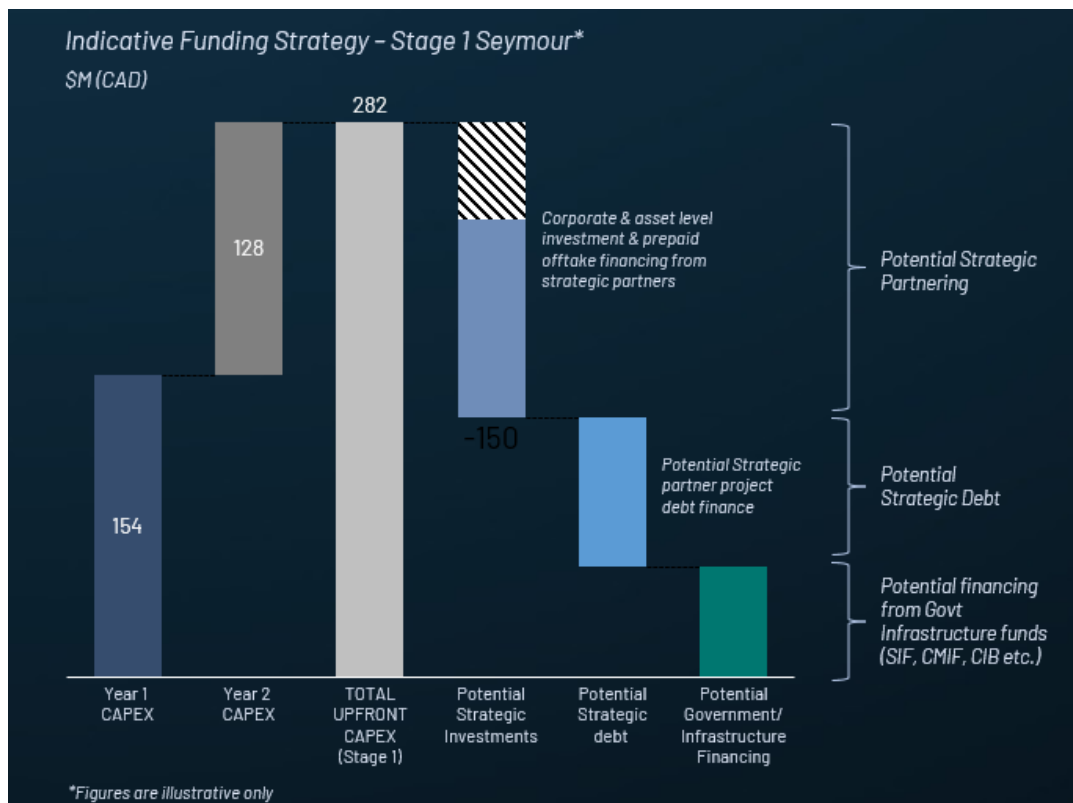

**Figure 5: Indicative potential funding structure for Stage 1 Seymour financing**

<sup>1</sup> GT1 may be required to conduct equity raisings that may be dilutive to existing holders or impact the value of existing securities

## Stage 2 – Lithium Hydroxide Conversion Facility

Financing will be completed over a 3-year period, staged to provide funding to ensure design, equipment procurement and construction milestones are met through the development phases. For the purpose of this study, the assumed milestones and financing commitment levels are based on an owner-operated model that provides funding as required based on these timeframes, similar to current projects being executed globally. No allowance has been made for timing constraints or additional requirements from strategic operator led funding regimes.

Discussions with strategic operators have commenced with GT1 having received initial structuring proposals that would entail investment for majority ownership (including the provision of funding) in the Conversion Facility by experienced operators that are currently producing Lithium Hydroxide and other battery chemicals. These would take the form of Joint venture structures with one or more partners potentially earning up to 60-70% of the equity in the Conversion Facility alongside GT1 as a minority shareholder in the facility. These structures are not finalised, nor are the processes advanced to indicate any future investment and all discussions are at concept level only at this stage. The potential however does provide for clear indication of the appetite to be part of GT1’s strategy based on Lithium supply chain in Ontario.

Complementing these strategic operator and funding initiatives will also include Government funding based on the Strategic Innovation Funding (SIF) application submitted by GT1 in 2022 to Invest Canada through the Innovation, Science and Economic Development (ISED) team. Ongoing discussions for this level of funding have been proceeding since the application with further updates and news expected in 2024.

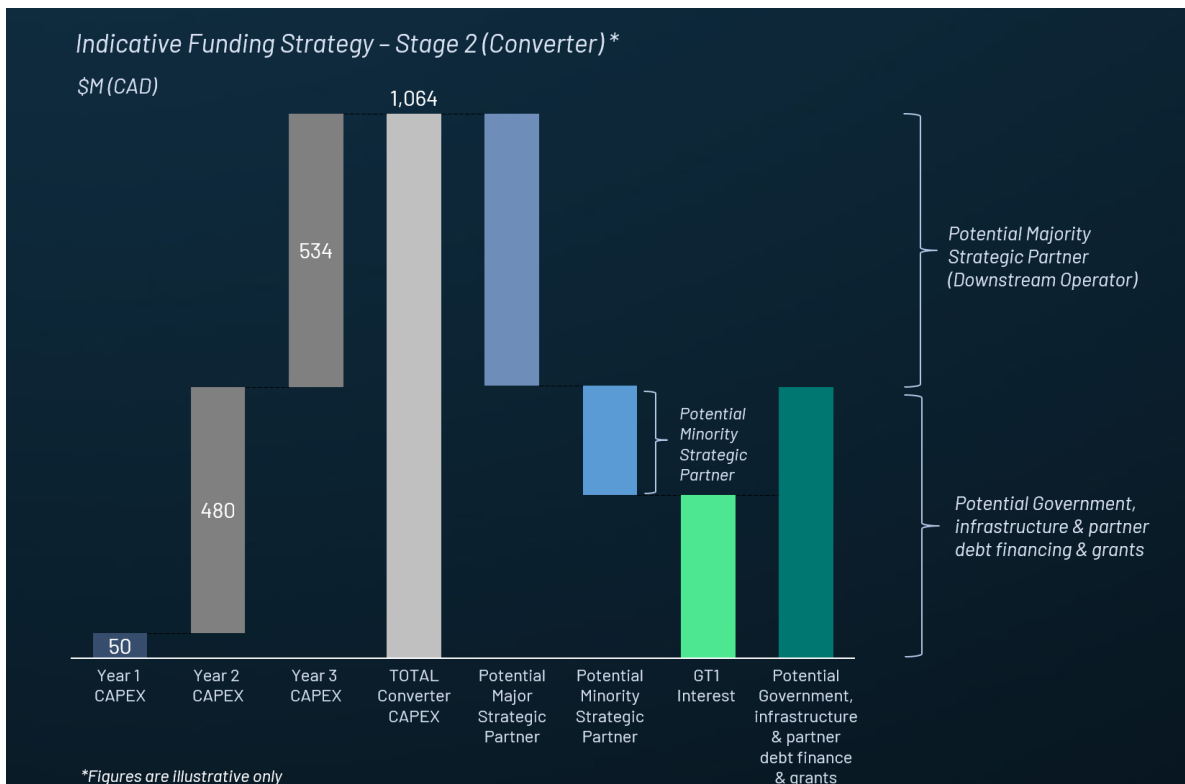

**Figure 6: Indicative Potential funding structure for Integrated strategy**

## Stage 3 – Root Mine & Concentrator

Currently, financing for the Root mine and concentrator development is phased over 2 years in years 5 and 6 of operation respectively. As the company is expected to be in a solid financial position at this stage, with the majority of start-up capital returned/paid back, the financing for Root has been assumed to be available through a conventional debt/working capital facility available to the company, and a similar potential asset level investment to Seymour.

## SENSITIVITY ANALYSIS

Sensitivity analysis has been performed on both economic cases studied that conclude similar drivers that have the major effect on the study outcomes. Assumed pricing values are the largest contributing factor to swing assumptions in Net Present Value of both projects studied. Pricing is next followed by processing parameters throughput or volume processed and the metallurgical recoveries of the contained metal.

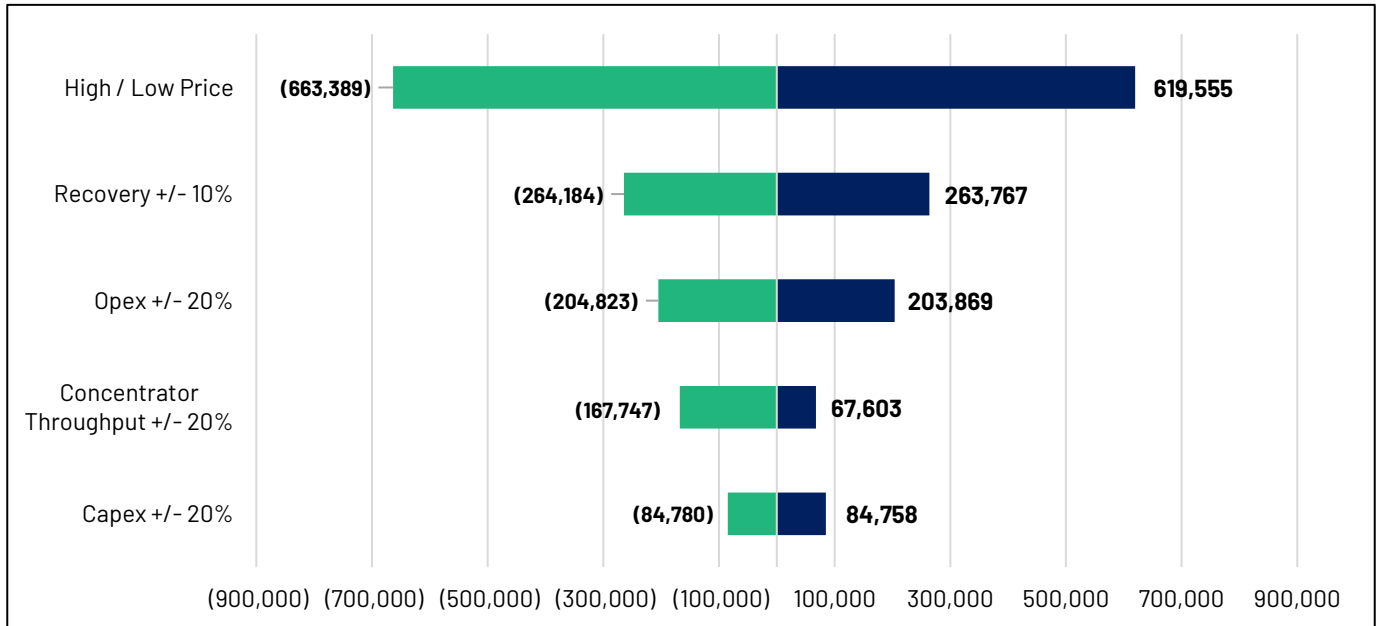

Figure 7: Mining and Concentrator sensitivity analysis

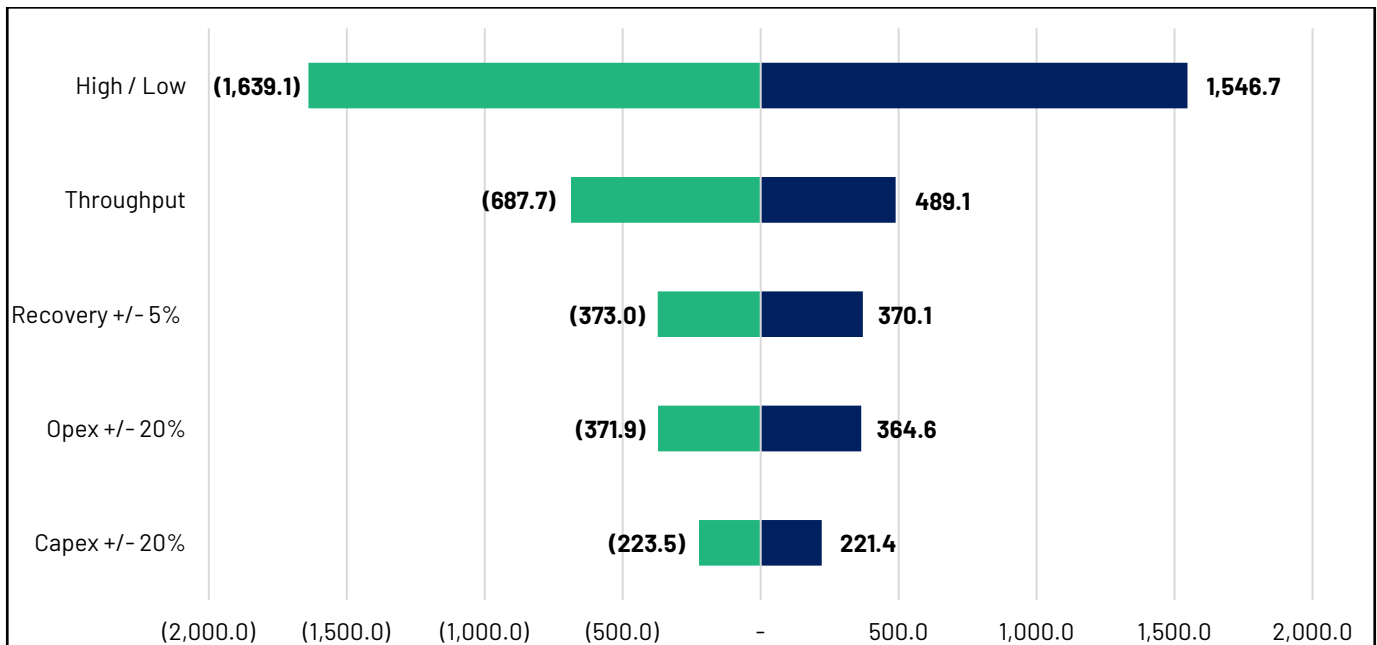

Figure 8: Integrated project sensitivity analysis

## MARKET OUTLOOK

GT1 has utilised the services of Fastmarkets, a leading independent lithium industry consultancy expert to provide a basis for the long-term lithium price forecasts for the PEA. Fastmarkets is a cross-commodity price reporting agency (PRA) in the metals and mining, new generation energy, agriculture, and forest products markets. The nature of the Fastmarkets industry predictions and market analysis is volatile in the current market situation given the expanding Lithium supply chain. Given these industry fluctuations in pricing GT1 has modelled several different pricing forecasts which define pricing as the key parameter for sensitivity as shown in the sensitivity tornado charts above in figure 6 & 7.

For the purposes of this study, the most recent pricing forecast from Fastmarkets (October 2023) has been used which uses an average spodumene concentrate price of USD\$2,029 FOB Thunder Bay. This pricing is based on the Fastmarkets average forecast price spanning from 2026 to 2032 and is adjusted for a 5.5% Li<sub>2</sub>O spodumene concentrate (SC 5.5) product. Further details regarding the lithium price forecast can be found in Figure 8.

The Lithium Hydroxide (LiOH:H<sub>2</sub>O) pricing is also based on this same report produced by Fastmarkets for battery grade product with an average price being applied in this study of USD\$25,460 per tonne FOB Thunder Bay.

The major financial assumptions, not detailed within this report, that have been utilised in the two scenarios are listed in Appendix B. Commodity forecasts are based on a Fastmarkets long term pricing study of 6.0% Li<sub>2</sub>O Spodumene Concentrate product and Battery Grade Lithium Hydroxide product undertaken in Q4 2023. The price used for SC5.5 was based on a pro rata of the SC6 price on Lithium volume. Hydroxide prices are assumed to be FOB from Thunder Bay. Details on the derivation of this price forecast are given in figure 9. The sensitivity analysis examines the high and low range that were identified in the Fastmarkets study.

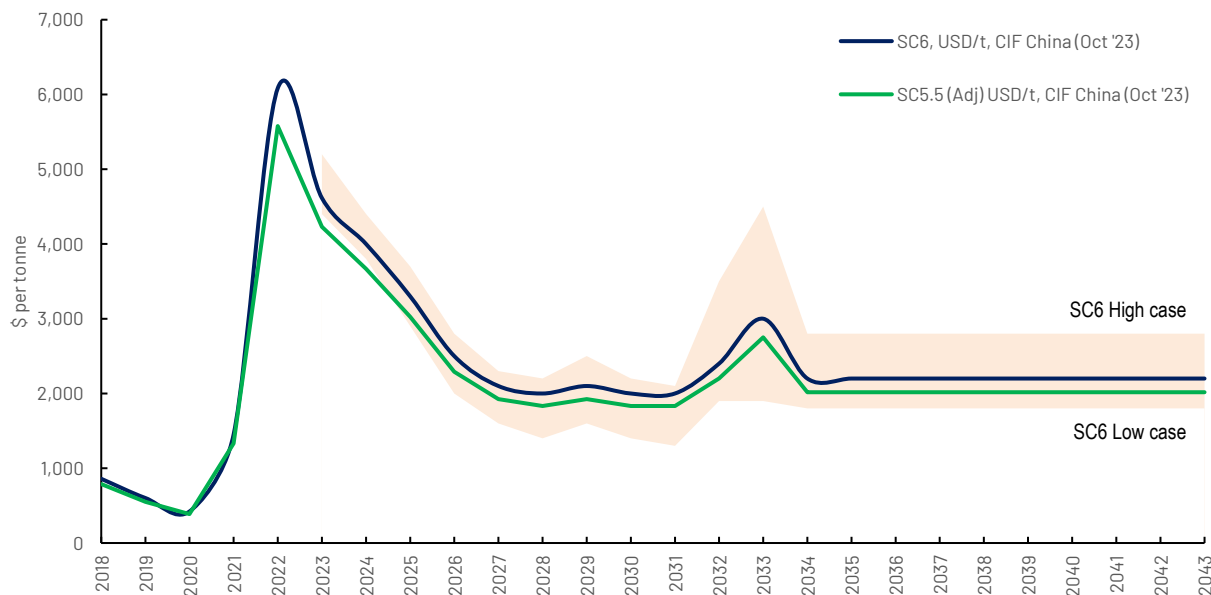

**Figure 9: Fastmarkets Pricing Forecast (Spodumene)**

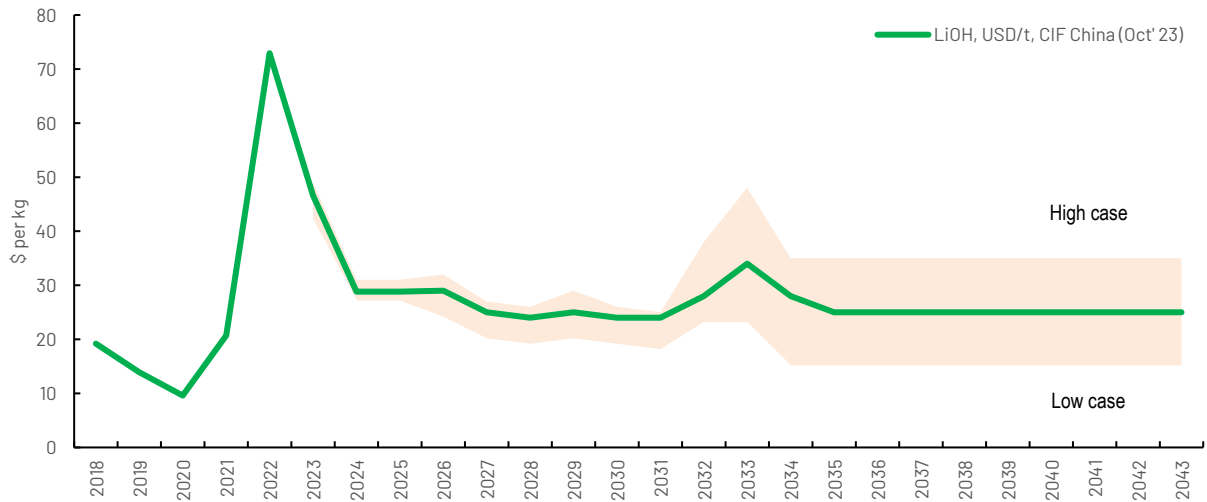

**Figure 10: Fastmarkets Pricing Forecast (Lithium Hydroxide)**

FastMarkets Price Forecast	2026	2027	2028	2029	2030	2031	2032	2033	2034	2035 onwards
LiOH(USD/tonne)	29,000	25,000	24,000	25,000	24,000	24,000	28,000	34,000	28,000	25,000
SC6(USD/tonne)	2,500	2,100	2,000	2,100	2,000	2,000	2,400	3,000	2,200	2,200
SC5.5(USD/tonne)	<b>2,292</b>	<b>1,925</b>	<b>1,833</b>	<b>1,925</b>	<b>1,833</b>	<b>1,833</b>	<b>2,200</b>	<b>2,750</b>	<b>2,017</b>	<b>2,017</b>

**Table 6: Yearly Price Assumptions**

## Seymour Permitting and Approvals

The permitting process continues on schedule, marked by the recent significant achievement of successfully obtaining the Mining Lease for the Seymour Lithium Project from the Department of Mines for a period of 21 years. The mining lease covers the proposed mining and processing construction areas of the Project and is a prerequisite before any project development activities. The granted Mining Lease for Seymour represents a significant achievement in de-risking the Project on the path toward development and production.

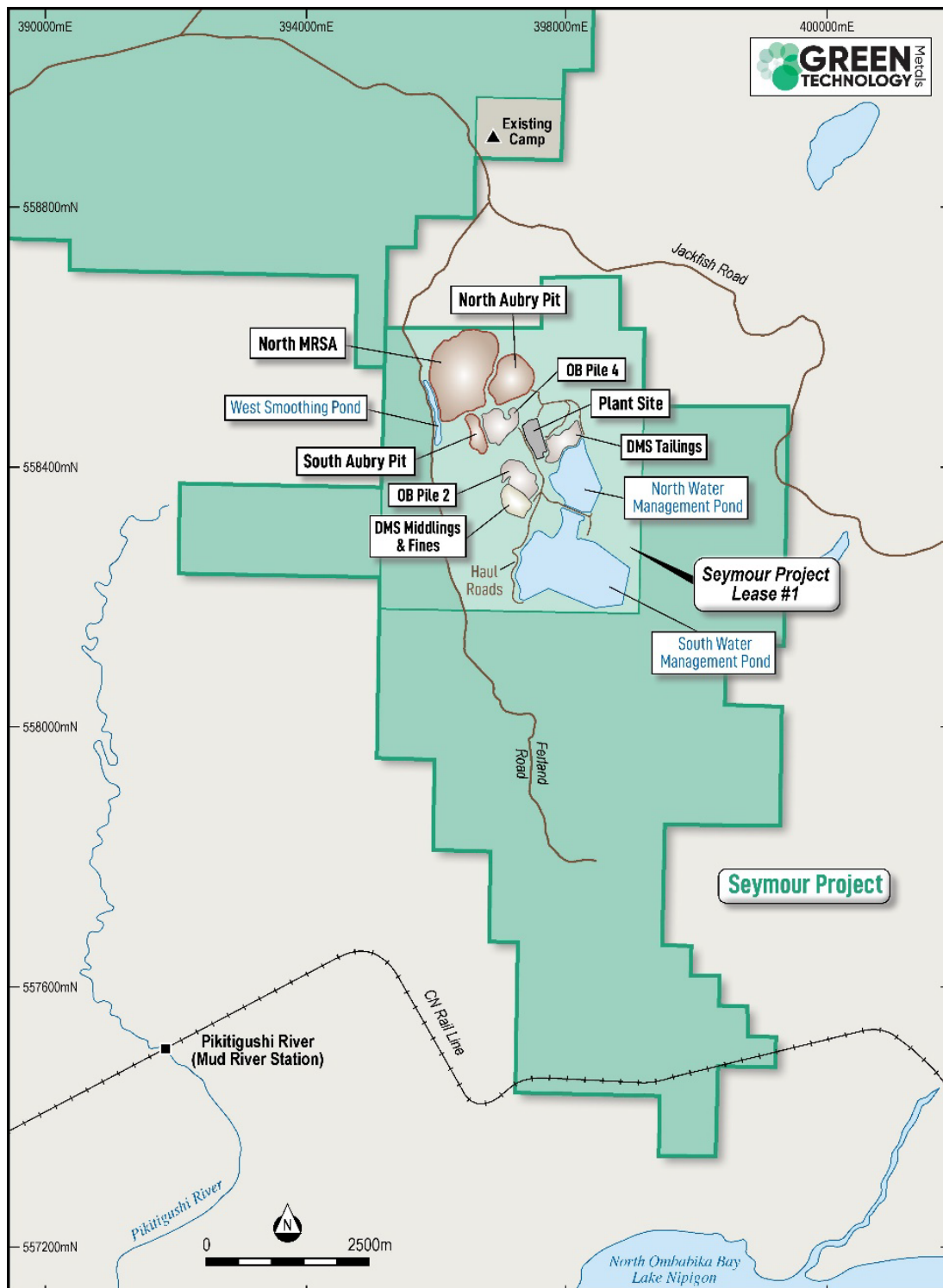

Figure 11: Seymour proposed layout and granted mining lease area

Additionally, in September 2023, marking 7 months post-submission, the company obtained its Environmental Assessment (EA) category determination from the Ministry of Natural Resources and Forestry (MNR). The determination clarifies the scope and procedures for the EA process that is required to be completed before MNR can issue permits for the project and this process is targeted to be completed in Q1 2024.

The company continues to prioritise engagement with Indigenous communities and government bodies as it works towards securing the remaining permits required to commence construction at the project. Presently, the company is working with First Nations in preparation for the timber harvesting that is planned to commence in the first quarter of 2024, contingent upon obtaining the necessary approvals in line with the project schedule.

GT1 maintains a positive relationship with pertinent government agencies and are active in discussions related to pre-submission consultation with relevant government departments for the permits listed in figure 12. Notably, GT1 is currently in discussions with the Ministry of Environment, Conservation and Parks (MECP) and is awaiting a determination regarding the potential necessity for permits under the Endangered Species Act. The company look forward to providing updates in the permitting process as it advances in the coming months.

Agency	Permit / Approval	Status
Ministry of Mines	Mining Lease – Mine Site	Approved
	Mining Lease – Camp	Submitted for approval
	Mining Lease – Stage 2	Submitted for approval
	Indigenous Consultation and Accommodation	Underway
	Closure Plan	Draft currently being used to facilitate consultation process
Ministry of Natural Resources and Forestry	Class Environmental Assessment Environmental Assessment category determination - Consultation - <b>underway</b>	Received
	Construction Permits Stage 1 - Permit to remove timber ( <b>Submitted for approval</b> ) - Lake and Rivers Improvement Act approval ((location approval; plans and specifications approval)	Underway
	Construction Permits Stage 2	Underway
	Overall Benefit Permit Determination if a permit is required is in progress by the Ministry	Planning
Ministry of Environment, Conservatory and Parks	Permit to Take Water	Application submission Q1 2024
	Air Environmental Compliance Approval	Application submission Q1 2024
	Sewage Environmental Compliance Approval	Application submission Q3 2024

**Figure 12: Indicative permitting schedule for the Seymour Lithium Project. All timing assumptions are indicative and subject to change.**

## Future work streams & opportunities

Given the favorable outcomes of the PEA, GT1 will move ahead to further study project enhancement opportunities through various work streams. The various project stages will now be separated and progressed individually within their own project and timelines. The timeline priorities will be in accordance with the stage set out below:

**Stage 1 – Seymour** (Eastern Hub) will proceed to DFS phase of assessment to enable optimization of the current designs, delivery strategy and economics and to enable a financial investment decision (FID) in Q3 2024.

- Focus on increasing mineral inventory and subsequently mine life by further exploration of Junior Lake projects and surrounding Seymour tenements. Every additional year of material feed will have a substantial effect on project economics and add additional feed tonnage to the proposed stage 2 development in Tunder Bay.
- Geotechnical study to steepen Overall Slope Angle and significantly reduce waste removal and subsequent costs
- Whittle shell selection to reduce strip ratios and total material movement as a function of ore recovery
- Mining cost model optimisation focusing on ore and waste CAD contractor rates to reduce overall mining costs
- Detailed staged cutback pit design to smooth grade, total material movement and equipment selection
- Open Pit and underground cross-over study to recover the remaining resource inventory at Seymour

- Infill drilling and conversion of resources to reserve for upcoming DFS.
- Continue with DFS concentrator testwork, and piloting of 100 tonne bulk sample to optimize flow sheet design and ensure economic evaluations.
- Further logistical studies to confirm supply chain logistics and optimization of transport costs.
- Water storage and site run-off treatment facility optimization
- Continue strategic partnership negotiations and lock down funding sources/strategy for Seymour initial capex, including government funding initiatives.

These work streams are currently budgeted for and will be completed for the release of the proposed DFS, although drilling and resource upgrades may not be completed.

**Stage 2 – Thunder Bay** – Lithium Conversion Facility to proceed to a Preliminary Feasibility Study (PFS) to further progress the development pathway in conjunction with potential operational partners. As part of those work streams the following is also proposed as a result of the study.

- Complete bench scale conversion work to produce Lithium Hydroxide
- Continue site selection assessment studies, and remediation costs/conditions associated with those locations in Thunder Bay
- Supply bulk concentrate sample to strategic operational processing partners to confirm flowsheet development and partnering process selection.
- Continue market assessment on production of hydroxide or carbonate and purity requirements.
- Commence basic engineering on plant site layouts, and utilities confirmation – including power study and early contract discussions with power providers.
- Phasing out low grade feed from Seymour with high grade feed from Root, ultimately increasing the grade during this transition period
- Continue strategic partnering, government funding and offtake discussions to further inform the PFS works streams, and financial structuring for future development.

The company envisage that the strategic partnering process will be completed by Q3 2024, with ultimate outputs being available to complete the proposed PFS on the conversion facility.

**Stage 3 – Root** (Western Hub) to proceed to a Preliminary Feasibility Study (PFS) phase of assessment. As the timeframe for permitting is governed by baseline studies and potential federal permitting approvals this work can be progressed at a slower rate. Additional works and tradeoffs that can be looked at in conjunction with the study:

- Continued drilling and exploration of both Root Bay East and West targets to further understand the regional geological setting, geo-metallurgy of the region along with building additional tonnage at resource level. The Root system and surrounding deposits have significant potential to upgrade and continue towards the exploration target of 25Mt. This will include preliminary assessment of underground scenarios and 'Root Deep's' prospects, targeting the deeper extensions of the orebody at Root Bay.
- Geotechnical study to steepen Overall Slope Angle and significantly reduce waste removal and subsequent costs.
- Detailed staged cutback design to smooth grade, total material movement and equipment selection.
- New pit design and ramp system to increase overall slope angle and reduce subsequent waste removal costs.
- Additional variability metallurgical testing to support a PFS for both Root Bay and McCombe pits.
- Optimised flow sheet development for coarser direct flotation – potential 'hydroflotation' and continued metallurgical testwork programs to optimize recovery.
- Ore sorting work to establish dilution reduction for open pit scenario.



## Indigenous Partners Acknowledgement

We express our gratitude to our Indigenous partners for granting us the privilege to operate on their Traditional Territory. We are dedicated to acknowledging and honoring those who have inhabited, traversed, and congregated on these lands since time immemorial. Green Technology Metals is steadfast in its commitment to safeguarding Indigenous heritage and endeavors to cultivate and promote a relationship with Indigenous Peoples that is founded on principles of mutual trust, respect, reciprocity, and collaboration, in alignment with the spirit of reconciliation.

*This ASX release has been approved for release by the Board.*

## KEY CONTACTS

### Investors

Luke Cox

### Chief Executive Officer

info@greentm.com.au

+61 8 6557 6825

### Media

Jacinta Martino

### Investor Relations and Media

ir@greentm.com.au

+61 430 147 046

## Green Technology Metals (ASX:GT1)

GT1 is a North American-focussed lithium exploration and development business with a current global Mineral Resource estimate of 24.9Mt at 1.13% Li<sub>2</sub>O.

Project	Tonnes (Mt)	Li <sub>2</sub> O (%)
<b>Root Project</b>		
<b>Root Bay</b>		
Indicated	9.4	1.30
Inferred	0.7	1.14
<b>McCombe</b>		
Inferred	4.5	1.01
<b>Total</b>	<b>14.6</b>	<b>1.21</b>
<b>Seymour Project</b>		
<b>North Aubry</b>		
Indicated	6.1	1.25
Inferred	2.1	0.8
<b>South Aubry</b>		
Inferred	2.0	0.6
<b>Total</b>	<b>10.3</b>	<b>1.03</b>
<b>Combined Total</b>	<b>24.9</b>	<b>1.13</b>

The Company's main 100% owned Ontario lithium projects comprise high-grade, hard rock spodumene assets (Seymour, Root, Junior and Wisa) and lithium exploration claims (Allison, Falcon, Gathering, Pennock and Superb) located on highly prospective Archean Greenstone tenure in north-west Ontario, Canada. All sites are proximate to excellent existing infrastructure (including clean hydro power generation and transmission facilities), readily accessible by road, and with nearby rail delivering transport optionality. Targeted exploration across all three projects delivers outstanding potential to grow resources rapidly and substantially.



<sup>1</sup> For full details of the Seymour Mineral Resource estimate, see GT1 ASX release dated 21 November 2023, *Seymour Resource Confidence Increased - Amended*. For full details of the Root Mineral Resource estimate, see GT1 ASX release 18 October 2023, *Significant resource and confidence level increase at Root, Global Resource Inventory now at 24.5Mt*. The Company confirms that it is not aware of any new information or data that materially affects the information in that release and that the material assumptions and technical parameters underpinning this estimate continue to apply and have not materially changed.

## APPENDIX A: IMPORTANT NOTICES

### Competent Person's Statements

The information in this report that relates to Exploration Results pertaining to the Project is based on, and fairly represents, information and supporting documentation either compiled or reviewed by Mr Stephen John Winterbottom who is a member of Australian Institute of Geoscientists (Member 6112). Mr Winterbottom is the General Manager – Technical Services of Green Technology Metals. Mr Winterbottom has sufficient experience which is relevant to the style of mineralisation and type of deposit under consideration and to the activity which he is undertaking to qualify as a Competent Person (CP) as defined in the 2012 Edition of the Joint Ore Reserves Committee (JORC) "Australasian Code for Reporting of Exploration Results, Mineral Resources and Ore Reserves". Mr Winterbottom consents to the inclusion in the report of the matters based on his information in the form and context in which it appears. Mr Winterbottom holds securities in the Company.

The information in this report relating to Metallurgical results is based on information reviewed by Mr Andrew Siemon (Member AusIMM). Mr Siemon has sufficient experience which is relevant to the treatment of the deposit(s) under consideration and to the activity which he is undertaking to qualify as a Competent Person as defined by the 2012 Edition of the Australasian Code for reporting of Exploration Results, Mineral Resources and Ore Reserves. Mr Siemon consents to the inclusion of the data in the form and context in which it appears in this release. Mr Siemon is the Principal Process Metallurgist of the Consulting Company and does not hold securities in the Company.

### No new information

Except where explicitly stated, this announcement contains references to prior exploration results and mineral resources all of which have been cross-referenced to previous market announcements made by the Company. The Company confirms that it is not aware of any new information or data that materially affects the information included in the relevant market announcements.

The information in this report relating to the Mineral Resource estimate for the Seymour Project is extracted from the Company's ASX announcement dated 17 and 21 November 2023. GT1 confirms that it is not aware of any new information or data that materially affects the information included in the original announcement and that all material assumptions and technical parameters underpinning the Mineral Resource estimate continue to apply.

The information in this report relating to the Mineral Resource estimate for the Root Project is extracted from the Company's ASX announcements dated 17 October 2023. GT1 confirms that it is not aware of any new information or data that materially affects the information included in the original announcement and that all material assumptions and technical parameters underpinning the Mineral Resource estimate continue to apply.

The Mineral Resource estimates underpinning the production target have been prepared by a competent person in accordance with the 2012 edition of the JORC Code.

## **Forward Looking Statements**

Certain information in this document refers to the intentions of Green Technology Metals Limited (ASX: GT1), however these are not intended to be forecasts, forward looking statements or statements about the future matters for the purposes of the Corporations Act or any other applicable law. Statements regarding plans with respect to GT1's projects are forward looking statements and can generally be identified by the use of words such as 'project', 'foresee', 'plan', 'expect', 'aim', 'intend', 'anticipate', 'believe', 'estimate', 'may', 'should', 'will' or similar expressions. There can be no assurance that the GT1's plans for its projects will proceed as expected and there can be no assurance of future events which are subject to risk, uncertainties and other actions that may cause GT1's actual results, performance or achievements to differ from those referred to in this document. While the information contained in this document has been prepared in good faith, there can be given no assurance or guarantee that the occurrence of these events referred to in the document will occur as contemplated. Accordingly, to the maximum extent permitted by law, GT1 and any of its affiliates and their directors, officers, employees, agents and advisors disclaim any liability whether direct or indirect, express or limited, contractual, tortious, statutory or otherwise, in respect of, the accuracy, reliability or completeness of the information in this document, or likelihood of fulfilment of any forward-looking statement or any event or results expressed or implied in any forward-looking statement; and do not make any representation or warranty, express or implied, as to the accuracy, reliability or completeness of the information in this document, or likelihood of fulfilment of any forward-looking statement or any event or results expressed or implied in any forward-looking statement; and disclaim all responsibility and liability for these forward-looking statements (including, without limitation, liability for negligence).

## APPENDIX B: PRELIMINARY ECONOMIC ASSESSMENT



---

# Preliminary Economic Assessment

DATE:

7 December 2023

# Preliminary Economic Assessment

## CONTENTS PAGE

1	EXECUTIVE SUMMARY .....	3
1.1	PROPERTY DESCRIPTION.....	4
1.2	ACCESSIBILITY, CLIMATE, LOCAL RESOURCES AND INFRASTRUCTURE .....	5
1.3	HISTORY.....	6
1.4	GEOLOGICAL SETTINGS, MINERALIZATION AND DEPOSIT.....	6
1.4.1	SEYMOUR PROPERTY .....	6
1.4.2	ROOT PROPERTY .....	8
1.5	EXPLORATION.....	9
1.5.1	SEYMOUR.....	9
1.5.2	ROOT .....	9
1.6	SAMPLE PREPARATION, ANALYSIS AND SECURITY .....	10
1.7	DATA VERIFICATION.....	10
1.8	METALLURGICAL TESTING AND MINERAL PROCESSING .....	10
1.8.1	SEYMOUR CONCENTRATOR TESTWORK .....	10
1.8.2	ROOT CONCENTRATOR TESTWORK .....	15
1.9	MINERAL RESOURCE ESTIMATE .....	17
1.10	ORE RESERVE ESTIMATES.....	19
1.11	MINING METHODS .....	19
1.11.1	PRODUCTION TARGET .....	19
1.11.2	MINERAL RESOURCE MODEL .....	20
1.11.3	MINING METHODS .....	20
1.12	PROCESSING AND RECOVERY METHODS .....	35
1.12.1	STAGE 1 SEYMOUR .....	35
1.12.2	STAGE 2 LITHIUM HYDROXIDE CONVERSION PLANT DESCRIPTION.....	36
1.12.3	STAGE 3 ROOT.....	37
1.13	INFRASTRUCTURE .....	38
1.13.1	STAGE 1 SEYMOUR .....	38
1.13.2	STAGE 2 CONVERSION FACILITY .....	43
1.13.3	STAGE 3 ROOT.....	47
1.14	MARKET ANALYSIS .....	49
1.14.1	LITHIUM SUPPLY AND DEMAND .....	49
1.14.2	LITHIUM PRICING .....	50
1.15	ENVIRONMENTAL STUDIES AND PERMITTING .....	51
1.16	CAPITAL AND OPERATING COSTS .....	53
1.16.1	STAGE 1 –SEYMOUR INITIAL CAPEX.....	54
1.16.2	STAGE 2 – CONVERSION INITIAL CAPEX.....	54

---

1.16.3	STAGE 3 –ROOT INITIAL CAPEX .....	55
1.16.4	SUSTAINING AND CLOSURE CAPEX .....	55
1.16.5	MINING OPERATING COSTS .....	56
1.16.6	STAGE 1 – SEYMOUR OPEX .....	56
1.16.7	STAGE 2 – CONVERSION FACILITY OPEX .....	57
1.16.8	STAGE 3 – ROOT OPEX.....	57
1.17	ECONOMIC MODEL AND SENSITIVITY ANALYSIS .....	58
1.17.1	FINANCIAL ASSUMPTIONS .....	59
1.17.2	TECHNICAL ASSUMPTIONS.....	60
1.17.3	SENSITIVITY ANALYSIS.....	61
1.18	INTERPRETATION AND CONCLUSIONS .....	62
1.19	RECOMMENDATIONS.....	63

## LIST OF TABLES

TABLE 1- 3	JUNE 2023 SEYMOUR MINERAL RESOURCE ESTIMATE FIGURES .....	17
TABLE 1-4	SEPTEMBER 2023 ROOT MINERAL RESOURCE ESTIMATE FIGURES.....	17
TABLE 1-5	SLOPE DESIGN PARAMETERS .....	21
TABLE 1-6	OPTIMISATION INPUTS AND PARAMETERS .....	22
TABLE 1-7	WASTE ROCK VOLUMES.....	23
TABLE 1-8	DESIGN ASSUMPTIONS .....	23
TABLE 1-9	OPTIMISATION SHELL TO PIT DESIGN – NORTH AUBRY .....	24
TABLE 1-10	OPTIMISATION SHELL TO PIT DESIGN – SOUTH AUBRY.....	24
TABLE 1-11	OPTIMISATION SHELL TO PIT DESIGN – ROOT BAY .....	24
TABLE 1-12	OPTIMISATION SHELL TO PIT DESIGN – MCCOMBE.....	25
TABLE 1-13	MINING SCHEDULE .....	33
TABLE 1-14	2023 PEA PRODUCTION TARGET (ENTECH, 2023) .....	35
TABLE 1-15	STAGE 1 SEYMOUR INITIAL CAPEX SUMMARY .....	54
TABLE 1-16	STAGE 2 CONVERSION FACILITY INITIAL CAPEX SUMMARY .....	54
TABLE 1-17	STAGE 3 ROOT INITIAL CAPEX SUMMARY .....	55
TABLE 1-18	SUSTAINING AND CLOSURE CAPEX SUMMARY .....	55
TABLE 1-19	TOTAL CAPITAL AND OPERATING MINING COSTS .....	56
TABLE 1-20	CONCENTRATOR: SPODUMENE PROCESSING PLANT OPEX SUMMARY – STAGE 1 – SEYMOUR PROJECT ....	56
TABLE 1-21	CONVERSION FACILITY OPEX SUMMARY .....	57
TABLE 1-22	SPODUMENE PROCESSING PLANT OPEX SUMMARY – STAGE 3 – ROOT BAY AND MCCOMBE PROJECT .....	58
TABLE 1-23	PROJECT RETURNS.....	59
TABLE 1-24	PROFIT & LOSS SUMMARY .....	59
TABLE 1-25	YEARLY PRICE ASSUMPTIONS .....	60
TABLE 1-26	FINANCIAL ASSUMPTIONS .....	60
TABLE 1-27	PROJECT PRODUCTION SUMMARY .....	61

## LIST OF FIGURES

FIGURE 1: INTEGRATED PROJECT STRATEGY .....	4
FIGURE 2: ROOT AND SEYMOUR PROPERTY LOCATION .....	5
FIGURE 3: AUBRY INTERPRETED PEGMATITES WITH OVERLAYED PIT DESIGNS .....	7
FIGURE 4: ROOT BAY DEPOSIT EXTENTS. ....	8
FIGURE 5: ROOT AND SEYMOUR REGIONAL GEOLOGICAL SETTING.....	9
FIGURE 6: GRADE RECOVERY CURVE FOR DMS / HLS LABORATORY TESTS FOR THREE COMPOSITES .....	12
FIGURE 7: DENSE MEDIA SEPARATION CONCENTRATE MAGNETIC RESPONSE .....	13
FIGURE 8: HLS TEST RESULTS (PURPLE CURVE) WITH SEYMOUR PREDICTED RECOVERY (GREEN CURVE).....	14
FIGURE 9: ROTARY KILN START (LHS) AND END (RHS) BULK CALCINATION TEST COMP 2 .....	16
FIGURE 10: OBLIQUE VIEW NORTH AUBRY BLOCK MODEL AND PIT DESIGN .....	18
FIGURE 11: OBLIQUE VIEW ROOT BAY BLOCK MODEL AND PIT DESIGN .....	18
FIGURE 12: OBLIQUE VIEW MCCOMBE BLOCK MODEL AND PIT DESIGN .....	19
FIGURE 13: PLAN VIEW OF PROPOSED PIT DESIGN - NORTH AUBRY.....	27
FIGURE 14: SECTION VIEW OF PROPOSED PIT DESIGN - NORTH AUBRY .....	27
FIGURE 15: LONG SECTION VIEW OF PROPOSED PIT DESIGN - NORTH AUBRY .....	28
FIGURE 16: PLAN VIEW OF PROPOSED PIT DESIGN - SOUTH AUBRY .....	28
FIGURE 17: SECTION VIEW PROPOSED PIT DESIGN - SOUTH AUBRY.....	29
FIGURE 18: LONG SECTION OF PROPOSED PIT DESIGN - SOUTH AUBRY .....	29
FIGURE 19: PLAN VIEW OF PROPOSED PIT SHELL - ROOT BAY .....	30
FIGURE 20: SECTION VIEW OF PROPOSED PIT SHELL FOR ROOT BAY.....	30
FIGURE 21: LONG SECTION VIEW OF PROPOSED PIT SHELL FOR ROOT BAY .....	31
FIGURE 22: PLAN VIEW OF PROPOSED PIT DESIGN - MCCOMBE .....	31
FIGURE 23: SECTION VIEW OF PROPOSED PIT DESIGN - MCCOMBE .....	32
FIGURE 24: LONG SECTION VIEW OF PROPOSED PIT DESIGN - MCCOMBE.....	32
FIGURE 25: MINED VOLUME BY MINING AREA (TOTAL).....	33
FIGURE 26: END OF YEAR ROM STOCKPILE TONNES AND $Li_2O$ GRADE BALANCE .....	34
FIGURE 27: MINED FEED MATERIAL TONNES AND $Li_2O$ TONNES BY MINING AREA .....	34
FIGURE 28: SEYMOUR PROJECT (STAGE 1) SIMPLIFIED CONCENTRATOR FLOW SHEET.....	36
FIGURE 29: SIMPLIFIED LITHIUM HYDROXIDE CONVERSION PLANT FLOWSHEET (CARBONATION LEACH).....	37
FIGURE 30: ROOT PROJECT (STAGE 3) SIMPLIFIED CONCENTRATOR FLOW SHEET .....	38
FIGURE 31: SEYMOUR PROJECT PROPOSED INFRASTRUCTURE .....	40
FIGURE 32: SEYMOUR CONCENTRATOR & MINE SERVICES AREA .....	41
FIGURE 33: SEYMOUR CRUSHING 3D SNAPSHOT (CLADDING REMOVED).....	42
FIGURE 34: DMS 3D SNAPSHOT (CLADDING REMOVED).....	42
FIGURE 35: LITHIUM HYDROXIDE CONVERSION PLANT LAYOUT .....	44
FIGURE 36: 3D MODEL OF THE LITHIUM HYDROXIDE CONVERSION PLANT.....	45
FIGURE 37: LITHIUM HYDROXIDE CONVERSION PLANT - SITE LOCATION.....	46
FIGURE 38: ROOT LAYOUT .....	47
FIGURE 39: ROOT CONCENTRATOR .....	48
FIGURE 40: ROOT GRINDING AND FLOTATION .....	49
FIGURE 41: LITHIUM SUPPLY AND DEMAND BALANCE .....	50
FIGURE 42: FASTMARKETS PRICING FORECAST (LITHIUM HYDROXIDE).....	51
FIGURE 43: FASTMARKETS PRICING FORECAST SPODUMENE CONCENTRATE.....	51
FIGURE 44: INDICATIVE PERMITTING SCHEDULE FOR THE SEYMOUR LITHIUM PROJECT.....	53
FIGURE 45: MINE AND CONCENTRATORS SENSITIVITY ANALYSIS .....	62
FIGURE 46: INTEGRATED PROJECT SENSITIVITY ANALYSIS.....	62

# Preliminary Economic Assessment

## 1 EXECUTIVE SUMMARY

Green Technology Metals Ltd (the **Company** or **GT1**) (ASX: GT1) is building a vertically integrated lithium business in Ontario to supply Lithium Chemicals into the North American electric vehicle (EV) supply chain. GT1's development strategy is to establish a regional supply chain with multiple mine and processing hubs feeding a central lithium conversion facility targeting the delivery of sustainable long-term lithium chemicals supply.

GT1 commissioned a Preliminary Economic Study evaluating two project development options:

- **Option 1: Mine and Concentrators** evaluates the economics of Spodumene production from both the Seymour Project and the Root Project over their respective mine lives, without a Converter. It includes all capital and operating costs for mining and concentrator operations and based on selling SC5.5 to external parties.
- **Option 2: Integrated Project** evaluates the economics of the Integrated project that includes the mines, concentrators and Lithium Hydroxide facility, over a 15-year mine life. This option is confined to the current Mineral Resource Estimates for both the Seymour and Root projects that the company foresees significant expansion through ongoing exploration efforts in the upcoming years.

The study was successfully completed in collaboration with internal staff with expertise in mine development, permitting and processing and a consortium of consultants both locally in Ontario and globally with a diverse range of specialised knowledge in various aspects of Lithium project development.

These consultants include; Englobe - specialists in Environmental and Geotechnical Engineering, Entech - with expertise in mine Geotechnical, planning and scheduling, Primero Group - specialising in Processing and Nordmin logistics and infrastructure engineering specialists. The valuable contributions from these companies have enabled GT1 to compile and finalise a comprehensive study.

GT1's project's are situated in Northwestern Ontario, a Tier-One global mining jurisdiction for lithium exploration and development, with proximity to existing infrastructure, mid and downstream suppliers in the electric vehicle supply chain and major high-tech population centers.

The vertically integrated approach (**Integrated Project**) is defined in Figure 1 and has three (3) distinct stages of development designed to lower the capital hurdle into production and facilitate the transition of the business into a producer. By implementing this strategy, the company aligns project cash flow with the broader goal of becoming the first producer in Ontario and enables project assessment and strategic partners to participate in the overall supply chain of Lithium Chemical supply being built out by GT1 in Ontario.

- **Stage 1** - Initially developing the North and South Aubury deposits at the Seymour project location or '**Eastern Hub**', processing ore through a DMS only concentrator to produce a spodumene concentrate ( $\text{Li}_2\text{O}$ ) for sale for the first three years of operation and feed for the converter thereafter, while storing middlings in a dry stacked storage facility for potential future processing.
- **Stage 2** - Developing a Lithium Conversion facility located in Thunder Bay approximately 320km from Seymour that will process the concentrate ores through a chemical conversion facility to produce a Lithium Hydroxide Monohydrate ( $\text{LiOH}\cdot\text{H}_2\text{O}$ ) chemical at battery grade purity, suitable for use in the electric vehicle supply chain in North America.
- **Stage 3** - Development of mines and a 'hybrid' style concentrator involving DMS and Flotation situated at the Western Hub or Root project, fed from the Root Bay and McCombe deposits to ensure consistent feed to the proposed conversion facility once the current mine life at Seymour has depleted.

The PEA is currently designed for a 15-year Life of Mine (**LOM**), utilising feed exclusively sourced from GT1's 100% owned projects. The study is presently confined to the Mineral Resources of the Seymour and Root projects, with the company foreseeing significant expansion through ongoing exploration efforts in the upcoming years. This includes the current extensive exploration program at the Root Bay deposit, as well as the planned drilling programs at the recently acquired Junior Lithium project along with other tenements that remain under-explored.

GT1 remains active in acquiring additional properties in proximity to both regional hubs, that may form part of the overall strategy and mine life inventory. GT1's growing geological understanding and assessment of the project areas remains



positive due to the number of fertile spodumene bearing pegmatites that have been uncovered during exploration success in the designated project areas.

The Company is optimistic about the converter facility's potential to operate for an additional 10 years beyond the scope of the current study. This extension is anticipated to yield an improved NPV for the integrated project. The extended operational period would surpass the current resource estimates from Stage 1 and Stage 3, potentially incorporating additional supply of SC5.5 feed from North American-based suppliers and the company is actively engaged in discussions with potential partners to implement this strategic expansion.

Additionally, the Thunder Bay Community Economic Development Commission (CEDC) is actively committed to fostering economic opportunities for the city. This includes providing support for various lithium resource projects in the region and the establishment of a lithium hydroxide facility within the city. GT1 envisions that this development scenario will result in a surplus of feed from both new and existing mineral resources in the region surrounding the Conversion facility, making it available as a feedstock over the remaining life of the Conversion facility.

GT1 has a clear strategy for future offtake agreements from the Seymour project, with 25% of spodumene concentrate or lithium hydroxide equivalent production already committed to LG Energy Solution for the first 5 years of production that will assist in financing the development of the Seymour project. GT1 will continue to engage with trading partners, strategic operators and mid/downstream manufacturers to allocate concentrate and chemical offtakes, and development partners in all stages of the strategy to ensure the appropriate level of investment, financing and alignment in the supply chain to build a complete North American Lithium Chemical supply business.

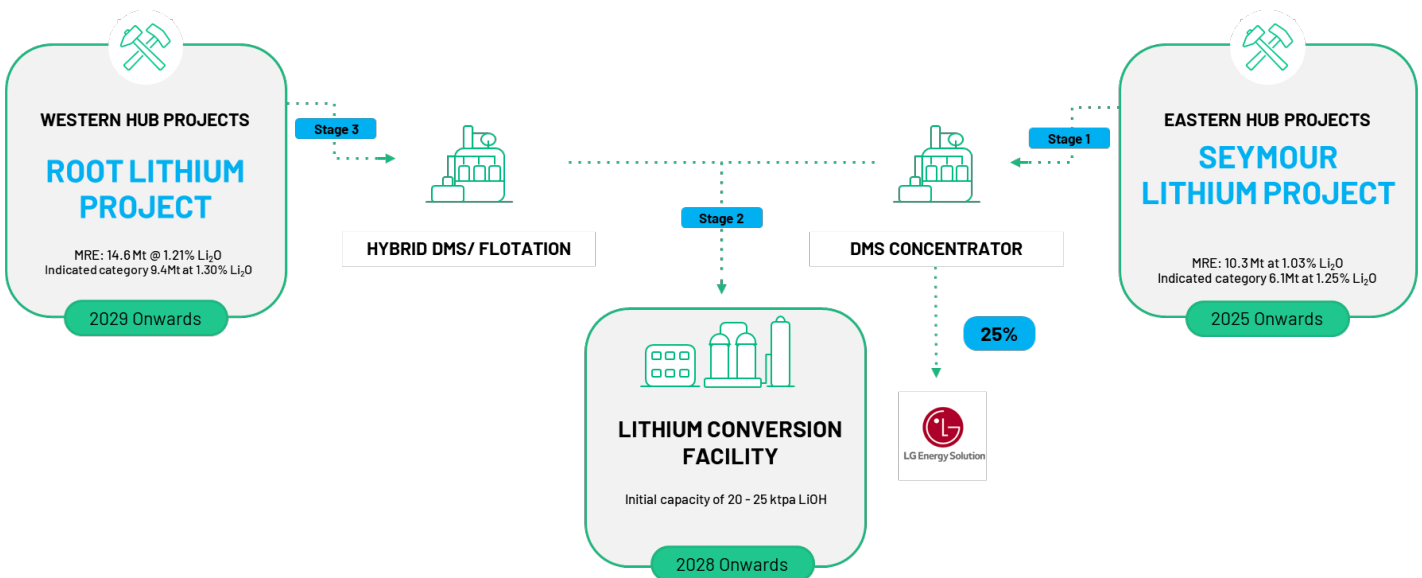

Figure 1: Integrated Project Strategy

## 1.1 Property Description

### EASTERN HUB - Seymour

The Seymour Property is located approximately 232 km NNE of Thunder Bay, Ontario (Figure 2). The centre of the Seymour Property is located on National Topographic System map sheet reference 52I/08 at approximately 50.429°N latitude and 88.473°W longitude. The Seymour Property is 15,140 hectares.

The Seymour Property consists of 736 single and boundary cell mining claims, spanning approximately 15,140 hectares. The claims are 100% owned by Green TM Resources (Canada) Ltd, a wholly owned subsidiary of Green Technology Metals Ltd. Surface rights to the Seymour Property remain with the Crown. GT1 has leased the mining claims that host the Seymour project site, in accordance with Section 81 of Ontario's Mining Act, to facilitate development into a mine.

**WESTERN HUB - Root**

The Root Property is located approximately 330 km NW of Thunder Bay, Ontario. The centre of the Root Property is located on National Topographic System map sheet reference 52J/13 at approximately 50.939°N latitude and 91.581°W longitude. The Root Property is 5362 hectares.

The Root Lithium Project consists of 249 single and boundary cell mining claims, 33 patent claims and 3 mining licence of occupation claims (285 total claims total) spanning approximately 5,377 hectares. Generally surface rights to the Root Property remain with the Crown, except for 9 Patent Claims.

**CONVERSION FACILITY**

For the purposes of this PEA the location for the Lithium Conversion facility will be in Northern Thunder Bay, on the north shore of the Lake Superior that serves as port access to Thunder Bay. The site location is situated on a brownfields existing industrial zoned property previously used to house a paper and pulp mill that was decommissioned in 2005.

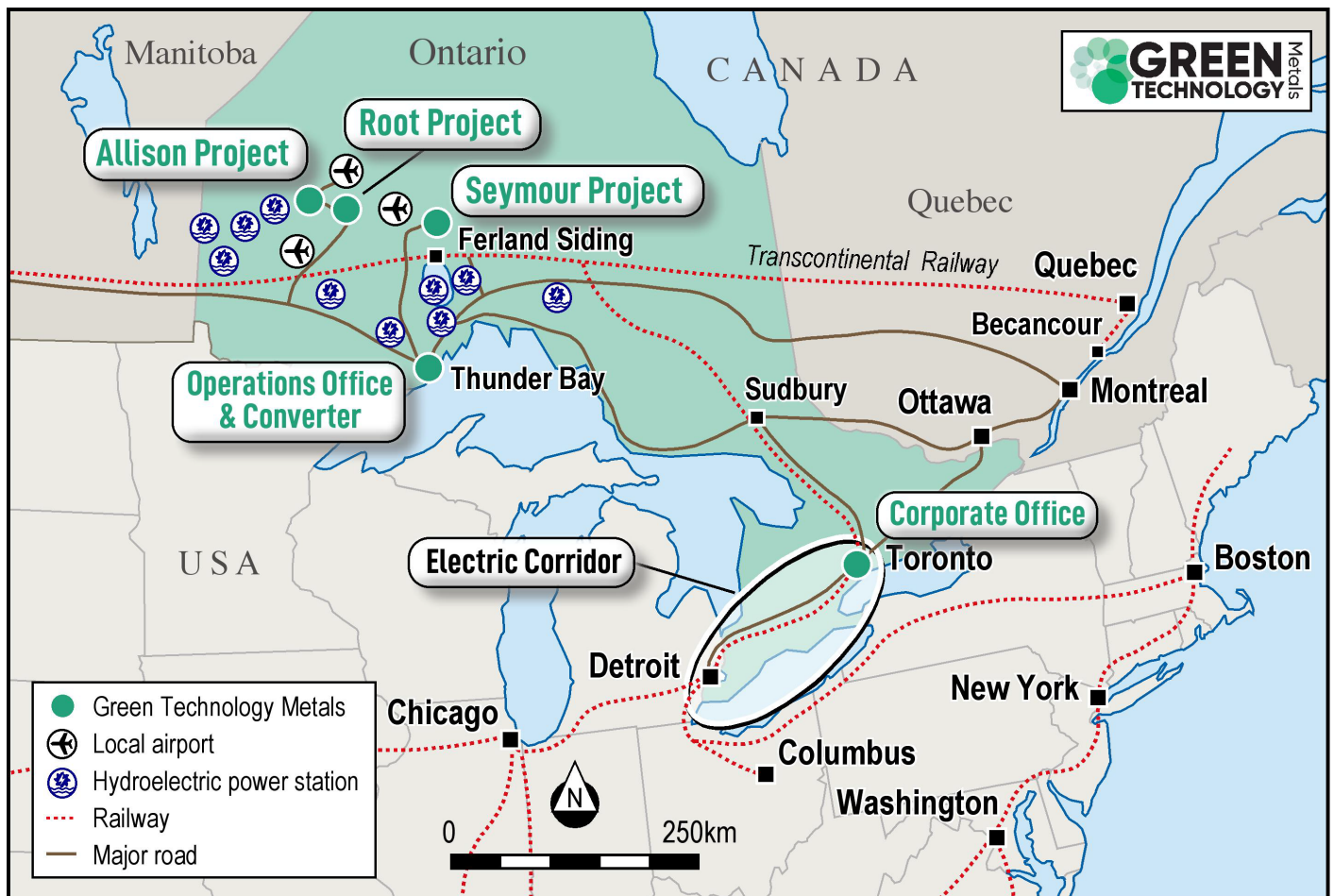

Figure 2: Root and Seymour Property Location

**1.2 Accessibility, Climate, Local Resources and Infrastructure**

The **Seymour** property is located between kilometre 57 to kilometre 60 of the all-weather, two-lane, Jackfish Main Haulage Road, east of Armstrong Station, north-western Ontario situated approximately 320 kms from the proposed conversion facility in Thunder Bay on the Robertson – Superior Treaty lands. The Property has excellent year-round access via the Jackfish Road, as well as proximity to existing rail sidings at Green Stations on the main CN rail line, just 30km south-west the Project. The Armstrong Ontario Ministry of Natural Resources (“MNR”) airfield, with two paved runways (ex-Canadian Forces Station), is located at kilometre 13, east of Armstrong.

The **Root** property is situated just north of Root Lake. Access to the Root property is via Sioux Lookout using Highway 516 then Vermilion River unsealed road (approximately 135km drive), these roads provide year-round access to the Root Property and Treaty 3 lands, on which the properties are situated. The Sioux Lookout Airport provides several daily flights to Thunder Bay, and the airstrip at Slate Falls First Nation is accessible by all-weather road and hosts paved runways and airport facilities.

The closest regional scale airport to both the Root and Seymour properties is located at Thunder Bay, which hosts multiple provincial flights daily from surrounding major cities and regions.

The Root and Seymour properties are within the Lac Seul Upland Eco-region of the Boreal Shield Terrestrial Ecozone (Wiken et al., 1996). The ecozone has long cold winters and short warm summers.

Currently no grid electric power connection is available on the Seymour property, however Ontario Power Generation Inc. (OPG) is proposing to develop up to 78 megawatts of renewable hydroelectric power through the construction of one generating station on the Little Jackfish River (Proposed Undertaking and in public consultation).

At the Root property, access to the recently completed, Wataynikaneyap 230 kV Hydro-powered transmission line, that runs approximately 300 kilometres from Dinorwic to Pickle Lake, Ontario, crosses the eastern claims at Root and is accessible with a few kilometres of the proposed Root (Western Hub) concentrator. The nearest rail access to the Root Property is the CN rail line located approximately 130km south of the Property.

The Thunder Bay site for the proposed conversion facility for Lithium Hydroxide is well suited and situated for development. The site sits on the northern side of the municipal city of Thunder Bay, a traditional industrial city of approximately 120,000 population and has existing infrastructure servicing the block such as power (Hydro One Networks Inc.), natural gas, municipal water and waste water service, heavy haulage roads, rail sidings and port access nearby.

### 1.3 History

The Seymour and Root Deposits were discovered in 1950s, with broad aeromagnetic surveys, surface sampling, mapping and diamond drilling resumed more recently by GT1.

GT1 have 100% ownership of the Root and Seymour properties. In June 2021, GT1 purchased an 80% interest in the Root and Seymour Properties which were 100% owned by Artiden Ltd, and subsequently in October 2022, GT1 announced it had completed a binding agreement to purchase the remaining 20% interest in the Root and Seymour Properties from Artiden Ltd., with the transaction was completed on 7 November 2022.

In October 2023, GT1 announced it had entered into and completed a binding sale agreement with Landore Ltd to acquire the Junior Lithium projects situated approx. 20 kms to the east of the Seymour project, as 100% owner.

All other GT1 properties shown on project and regional maps are 100% owned and/or managed by GT1 but are not part of this study.

### 1.4 Geological Settings, Mineralization and Deposit

The Seymour and Root Properties lie within the Precambrian Canadian Shield that underlies approximately 60% of Ontario. The Shield can be divided into three major geological and physiographic regions, from the oldest in the northwest to the youngest in the southeast. All projects are located in the highly prospective greenstone belts that have regional history of spodumene bearing pegmatite discoveries and occurrences.

#### 1.4.1 Seymour Property

The Seymour Property is located within the eastern part of the Wabigoon Sub-province, near the boundary with the English River Sub-province to the north. These sub-provinces are part of the Superior Craton, comprised mainly of Archaean rocks but also containing some Mesoproterozoic rocks such as the Nipigon Diabase.

Pegmatites are reasonably common in the region intruding the enclosing host rocks after metamorphism, evident from the way the pegmatites cut across the well-developed foliation within the metamorphosed host rocks. This post-dating relationship is supported by radiometric dating; an age of 2666 ± 6 Ma is given for the timing of intrusion of the pegmatites (Breaks, et al., 2006).

The pegmatites in North Aubry have a northeast plunge direction varying from 10 to 35 degrees from horizontal some 800m downdip extent and 250-300m strike. The North Upper and North Upper high-grade component within, appears to wedge towards the southeast and is still open down dip and to the northwest.

Southern pegmatites are thinner and less well developed with higher muscovite content and appear to have a more north to north-westerly trend and dip more shallowly to the east. These pegmatites are also hosted in pillow basalts.

The pegmatites are zoned with better developed spodumene crystal appearing as bands, often at an acute angle to the general trend of the pegmatite.

The dominant economic minerals are spodumene with varying proportions of muscovite, microcline, and minor petalite and lepidolite.

The adjacent pillow basalts contain minor disseminated pyrite and pyrrhotite.

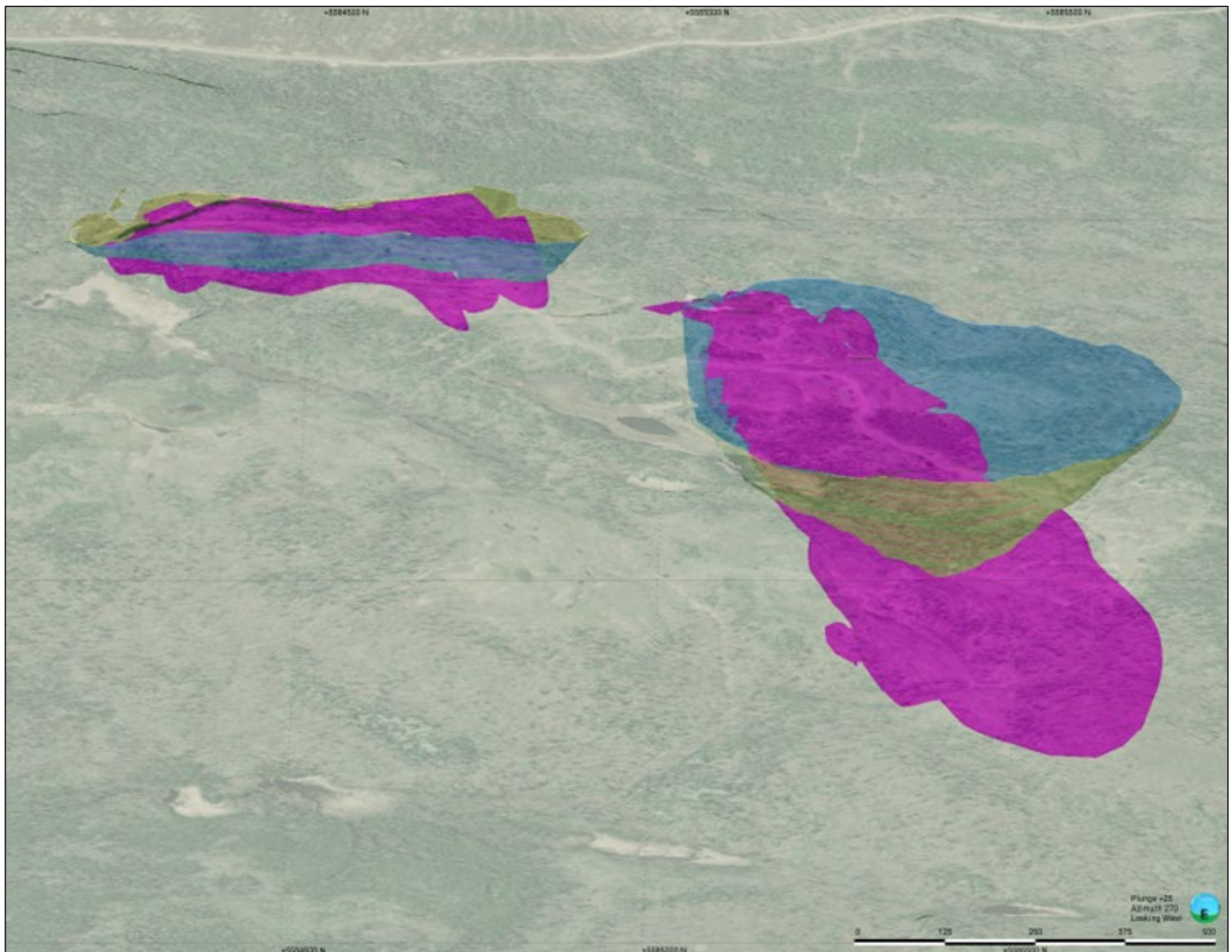

**Figure 3: Aubry Interpreted Pegmatites with Overlaid Pit Designs**

### 1.4.2 Root Property

The Root Property contains most of the pegmatites within the Root Lake Pegmatite Group including the McCombe Pegmatite, Morrison Prospect, Root Lake Prospect and Root Bay deposit. The McCombe Pegmatite and Morrison Prospect are hosted in predominately mafic metavolcanic rock of the Uchi Domain. The Root Lake and Root Bay pegmatites are hosted in predominately metasedimentary rocks of the English River Terrane. On the eastern end of the Root Lithium Asset there is a gold showing (Root Bay Gold Prospect) hosted in or proximal to silicate, carbonate, sulphide, and oxide iron formations of the English River Terrane.

The Root Pegmatites are internally zoned. These zones are classified by the tourmaline discontinuous zone along the pegmatite contact, white feldspar-rich wall zone, tourmaline-bearing, equigranular to porphyritic potassium feldspar sodic apalite zone, tourmaline-bearing, porphyritic potassium feldspar spodumene pegmatite zone and lepidolite-rich pods and seams (Breaks et al., 2003). The Root pegmatites have been classified as complex-type, spodumene-subtype (Černý 1991a classification) based on the abundance of spodumene, highly evolved potassium feldspar chemistry and presence of petalite, mircolite, lepidolite and lithium-calcium liddicoatite (Breaks et al., 2003).

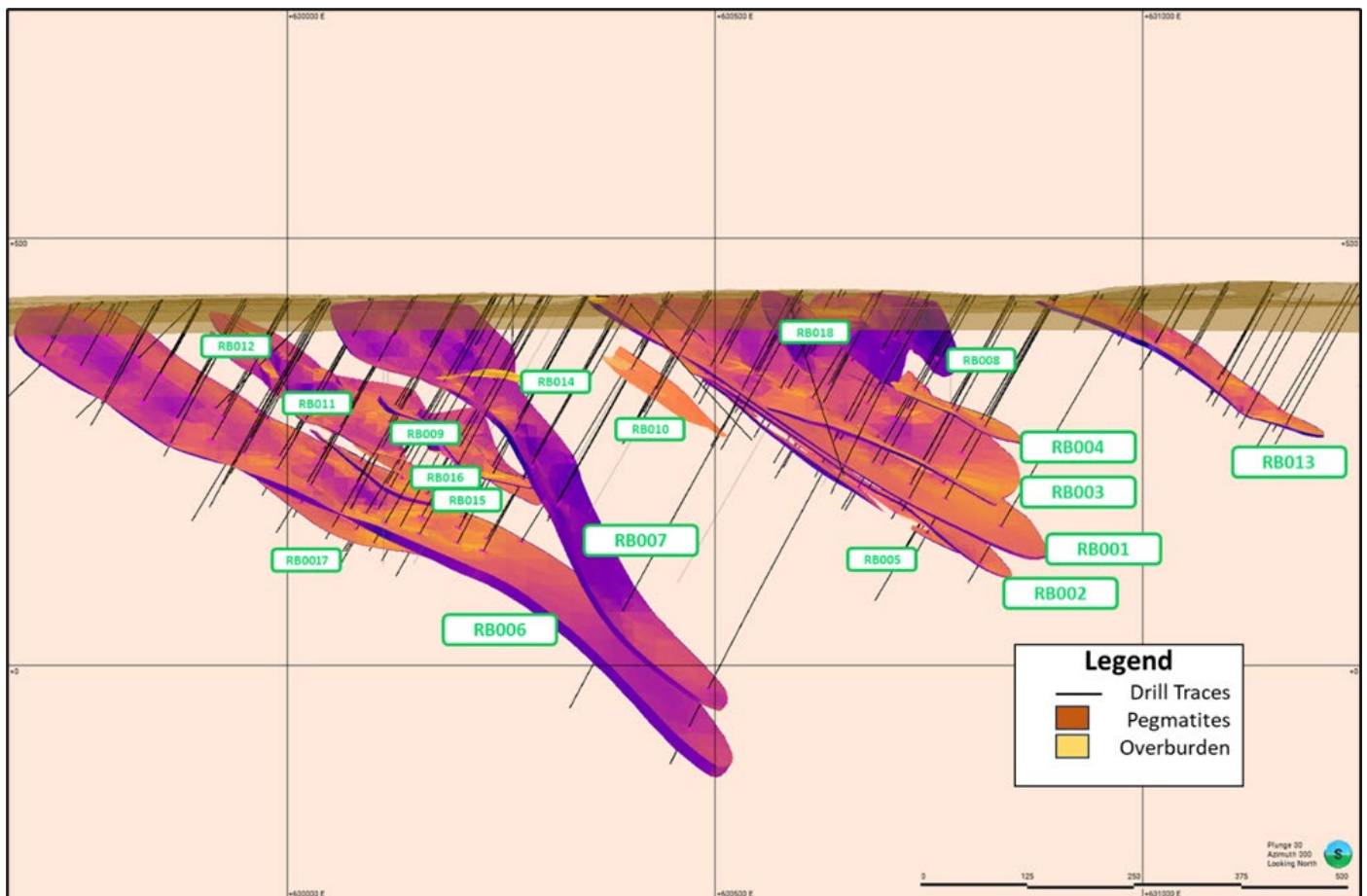

Figure 4: Root Bay Deposit Extents.

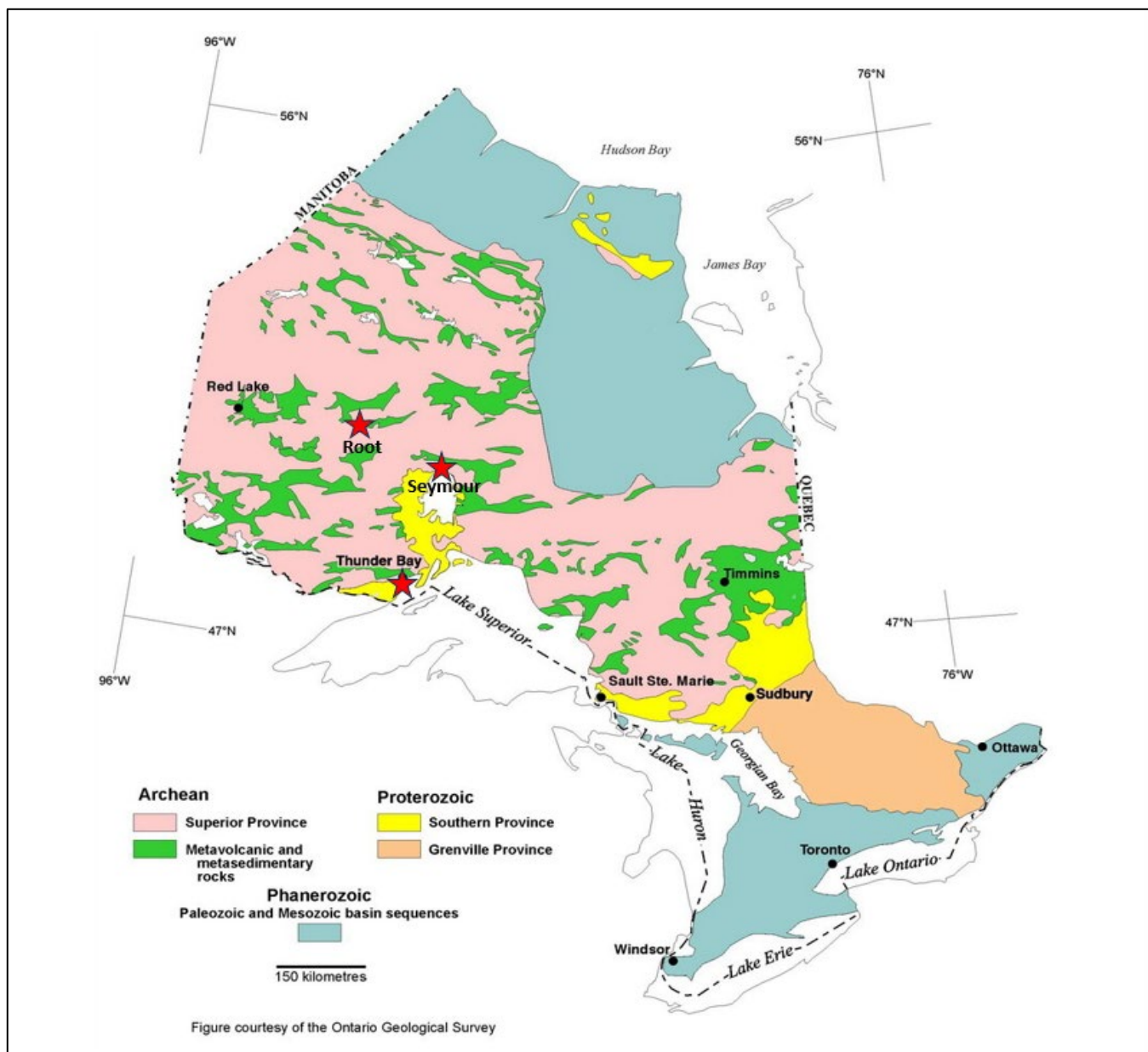

Figure 5: Root and Seymour Regional Geological Setting

## 1.5 Exploration

GT1 has flown both Lidar and aeromagnetic surveys at both the Seymour and Root Properties in 2021 and 2022 to generate further exploration targets at these properties.

### 1.5.1 Seymour

In 2021, GT1 initiated drilling activities at Seymour with an ongoing objective to enhance the confidence in the North Aubry mineral resource estimation and to investigate exploration targets identified through surface sampling and aeromagnetic interpretation. The drilling campaign encompassed a total of 370 holes, amounting to 56,143 meters, and contributed to the latest Mineral Resource Estimate (MRE) update as of November 17, 2023. Within this overall drilling effort, GT1 specifically completed 163 holes, covering a distance of 34,728 meters using NQ diamond core on the property. Future exploration endeavors will extend to the underexplored northern tenement area.

## Preliminary Economic Assessment

### 1.5.2 Root

GT1 initiated drilling activities at the Root Property in 2022, and these efforts are ongoing into 2023. In the early part of 2023, the focus of drilling was on substantiating the historical McCombe Deposit, originally identified in the 1950s. Additional drilling efforts were directed at other priority target areas, specifically the Morrison and Root Bay deposits located to the east of McCombe. By May 2023, drilling had successfully defined an Inferred Mineral Resource at Root Bay, and subsequent infill drilling expanded and refined this resource by September 2023. As of the most recent Mineral Resource Estimate (MRE) update on October 18, 2023, GT1 has completed a total of 56,965 meters of diamond NQ drilling at the Root project.

### 1.6 Sample Preparation, Analysis and Security

All core and samples were supervised and secured in a locked vehicle, warehouse, or container until delivery to the Thunder Bay laboratory for cutting, preparation and analysis.

GT1 conducted rigorous quality control protocols using certified reference material to verify the veracity of laboratory assay returns. This was done on a batch-by-batch basis with standards and blanks inserted a minimum of 1 in 20 samples. Results were plotted on control charts to identify assaying trends and laboratory precision and bias.

GT1 personnel visited both laboratories used on several occasions to confirm sample handling and preparation processes.

### 1.7 Data Verification

Various site visits to Seymour project were undertaken by the Competent Person (John Winterbottom) these included between 8<sup>th</sup> and 9<sup>th</sup> June 2022, 2<sup>nd</sup> to 5<sup>th</sup> October 2022, 14<sup>th</sup> to 15<sup>th</sup> March 2023 and 9<sup>th</sup> to 11<sup>th</sup> August 2023; the general site layout, drilling sites and diamond drilling operations were viewed, plus diamond core in the storage facility at Thunder Bay.

Drill collar locations were compared to Lidar terrain elevation data.

All data is uploaded directly into a SQL database managed by a third-party database administrator.

The Seymour and Root data, in the view of the Competent Person, is suitable for mineral resource estimation at the level of confidence applied to the estimate.

### 1.8 Metallurgical Testing and Mineral Processing

#### 1.8.1 Seymour Concentrator Testwork

The Seymour metallurgical testwork program was undertaken at 4 laboratories:

- SGS Lakefield (SGS) – Initial HLS testwork
- Saskatchewan Research Council (SRC) – HLS, DMS and Grindability testwork
- Eriez – Magnetic Separation
- Nagrom – Reflux classifier testwork

SGS Lakefield conducted heavy liquid separation (HLS) tests on a Main composite ore sample in late 2022 generated from drill core comprising of 20% high grade (High), 20% medium high grade (Mid High), 20% medium low grade (Mid Low) and 40% low grade (LG) material, to give a nominal average composite grade of 1.05% Li<sub>2</sub>O.

HLS laboratory testwork at SGS on the Main composite at various crush sizes was undertaken with the following results achieved:

- 12.5mm top size generated a 4.92% Li<sub>2</sub>O concentrate with recovery of 71.5% Li<sub>2</sub>O and a 3.81% Fe<sub>2</sub>O<sub>3</sub> grade
- 9.5mm top size generated a 5.5% Li<sub>2</sub>O concentrate with recovery of 73.6% Li<sub>2</sub>O and a 2.96% Fe<sub>2</sub>O<sub>3</sub> grade
- 8.0mm top size generated a 5.5% Li<sub>2</sub>O concentrate with recovery of 81.2% Li<sub>2</sub>O and a 3.0% Fe<sub>2</sub>O<sub>3</sub> grade

Based on these results, 9.5mm (10.0mm) was used for the future testwork programs and basis of design.

Saskatchewan Research Council (SRC) in Saskatoon, Saskatchewan conducted testwork during 2023 on three variability samples from the GT1 Seymour Project. Sample characterization indicated Spodumene ( $\text{LiAlSi}_2\text{O}_6$ ) was the only lithium-bearing mineral identified in the samples, while illite, hornblende and biotite were the main iron-bearing minerals identified. Spodumene content in the variability samples ranged from 5.2% to 16.8%.

The SRC testwork program included sample characterization and heavy liquid separation (HLS), and bulk DMS tests. The samples were generated from North Aubry material which represents material that would be mined in the early years of operation. Each sample contained both pegmatite and host rock (dilution).

The three variability samples (composites) were compiled by SRC on the as-received drill core, and given the designations:

- MHG – medium high grade ( $\text{Li}_2\text{O}$  – 1.41%, 1.05%  $\text{Fe}_2\text{O}_3$ ),
- MLG – medium low grade ( $\text{Li}_2\text{O}$  – 0.85%, 1.04%  $\text{Fe}_2\text{O}_3$ ),
- LG – low grade ( $\text{Li}_2\text{O}$  – 0.62%, 1.41%  $\text{Fe}_2\text{O}_3$ ).

Lithia ( $\text{Li}_2\text{O}$ ) concentration of the 3 variability samples ranged from 0.6% to 1.4%, clearly following the low to high grade distinction. There was little difference in the iron (III) oxide ( $\text{Fe}_2\text{O}_3$ ) assays between the medium high grade (MHG) (1.05 %) and medium low grade (MLG) (1.04 %) samples, though this increased for the low grade (LG) material to 1.4%.

Standard Bond tests were conducted to determine grindability. Due to sample mass limitations with the LG variability sample, only the MHG and MLG variability samples underwent grindability testing. Bond rod mill work index (BRWi) ranged from 11.8 kWh/t to 12.7 kWh/t, whilst Bond ball mill work index (BBWi) ranged from 16.3 kWh/t to 17.0 kWh/t.

### 1.8.1.1 HLS Laboratory Testwork

HLS testwork at SRC on the MHG and MLG variability composites at various crush sizes was undertaken with the following results achieved:

- MLG - 10.0mm crush top size generated a 5.5%  $\text{Li}_2\text{O}$  concentrate with global recovery of 70.4%  $\text{Li}_2\text{O}$  and a 3.35%  $\text{Fe}_2\text{O}_3$  grade, for a 1.4% feed grade. It should be noted that the contained iron may reduce the concentrate value.
  - Fines material had a lithium department of 64.6% to produce a 5.5%  $\text{Li}_2\text{O}$  concentrate, 3.48%  $\text{Fe}_2\text{O}_3$
  - Coarse material had a lithium department of 74.3% to produce a 5.5%  $\text{Li}_2\text{O}$  concentrate, with 3.27%  $\text{Fe}_2\text{O}_3$
- MHG - 10.0mm crush top size generated a 5.5%  $\text{Li}_2\text{O}$  concentrate with global recovery of 80.7%  $\text{Li}_2\text{O}$  and a 2.55%  $\text{Fe}_2\text{O}_3$  grade
  - Fines material had a lithium department of 80.7% to produce a 5.5%  $\text{Li}_2\text{O}$  concentrate, 2.18%  $\text{Fe}_2\text{O}_3$ .
  - Coarse material had a lithium department of 80.5% to produce a 5.5%  $\text{Li}_2\text{O}$  concentrate, with 2.92%  $\text{Fe}_2\text{O}_3$ .

### 1.8.1.2 Bulk DMS/HLS Testwork

Bulk DMS/HLS tests were conducted at SRC to closely align with the proposed flowsheet, with a mica reflux removal, followed by 2-stage DMS on the coarse and fines streams. The lithium DMS recovery results are presented in Figure 6 and show that a 5.5%  $\text{Li}_2\text{O}$  concentrate can be generated with a recovery of 78% for the high-grade composite with a grade of 1.4%  $\text{Li}_2\text{O}$ . Though it should be noted the iron content of this concentrate does not meet the specification of <1.4%  $\text{Fe}_2\text{O}_3$ .



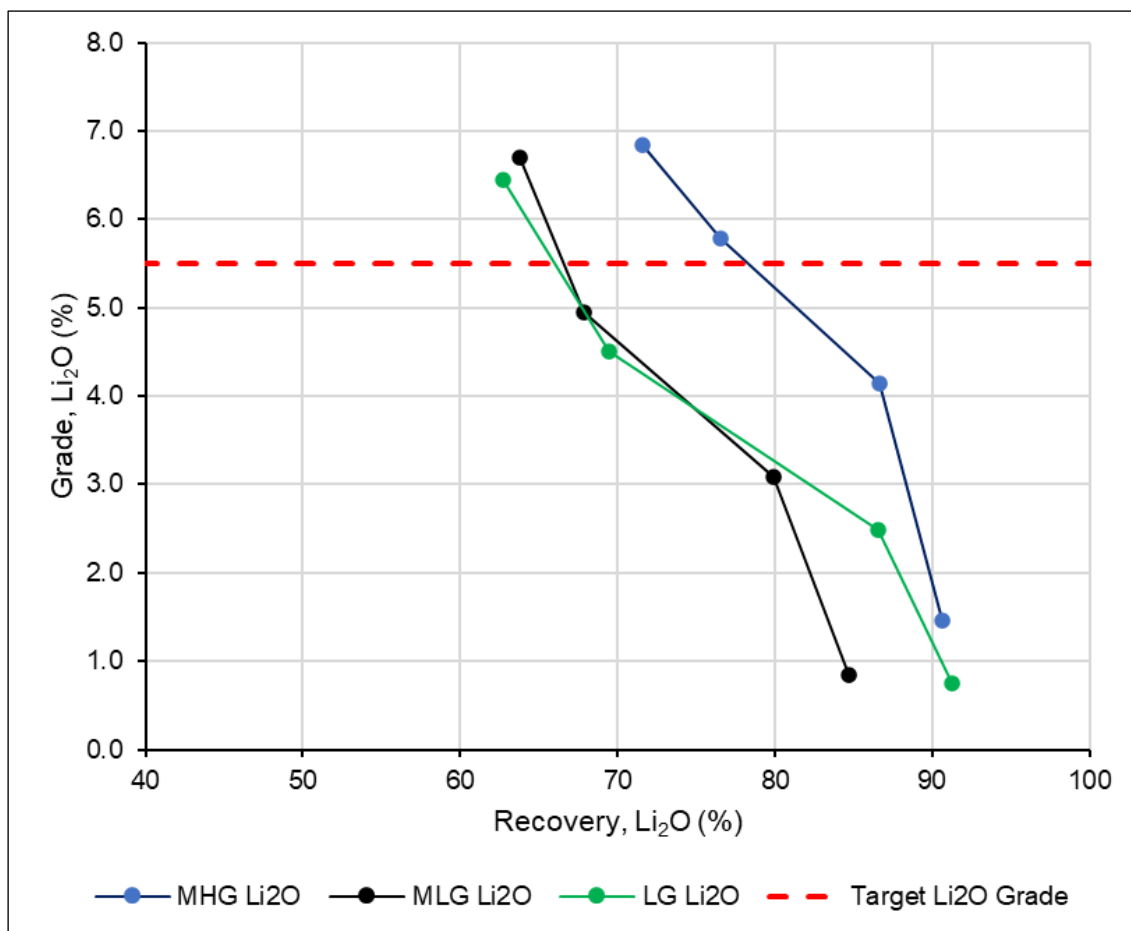

Figure 6: Grade Recovery Curve for DMS / HLS Laboratory Tests for three composites

### 1.8.1.3 Mica Removal – Reflux Classifiers

A total of three up-current classification tests were conducted at Nagrom on a Reflux Classifier (RC100) to understand the samples susceptibility to removal of micaceous mineral types (muscovite etc.), prior to DMS. Preliminary testwork shows that the material is amenable to reflux classification at upflow velocities of 0.08 - 0.14 m/s, as lithium losses remained >1% and the composition of the upflow remained >80% mica below 0.14 m/s.

Removal of any mica is advantageous to any DMS circuit as it minimizes the risk of screen blinding and poor unit operation (DMS cyclone/dewatering screens). So though only a small portion of the total mica contained was removed there is sufficient to justify the capital cost.

### 1.8.1.4 Magnetic Removal

The DMS products generated were then magnetically separated through a test program undertaken by Eriez on the fine and coarse DMS product to gauge sample susceptibility to iron removal. Results show that iron can be removed with lithium losses below 11% to achieve Fe<sub>2</sub>O<sub>3</sub> grades <1.4% (refer to Figure 7), with the exclusion of the coarse low-grade sample (LG).

However, the current proposed flowsheet excludes coarse magnetic separation due to commercial equipment capabilities and limited bulk testwork undertaken on coarse feeds. The inclusion in future will be considered if additional testwork and equipment supply limits are met.

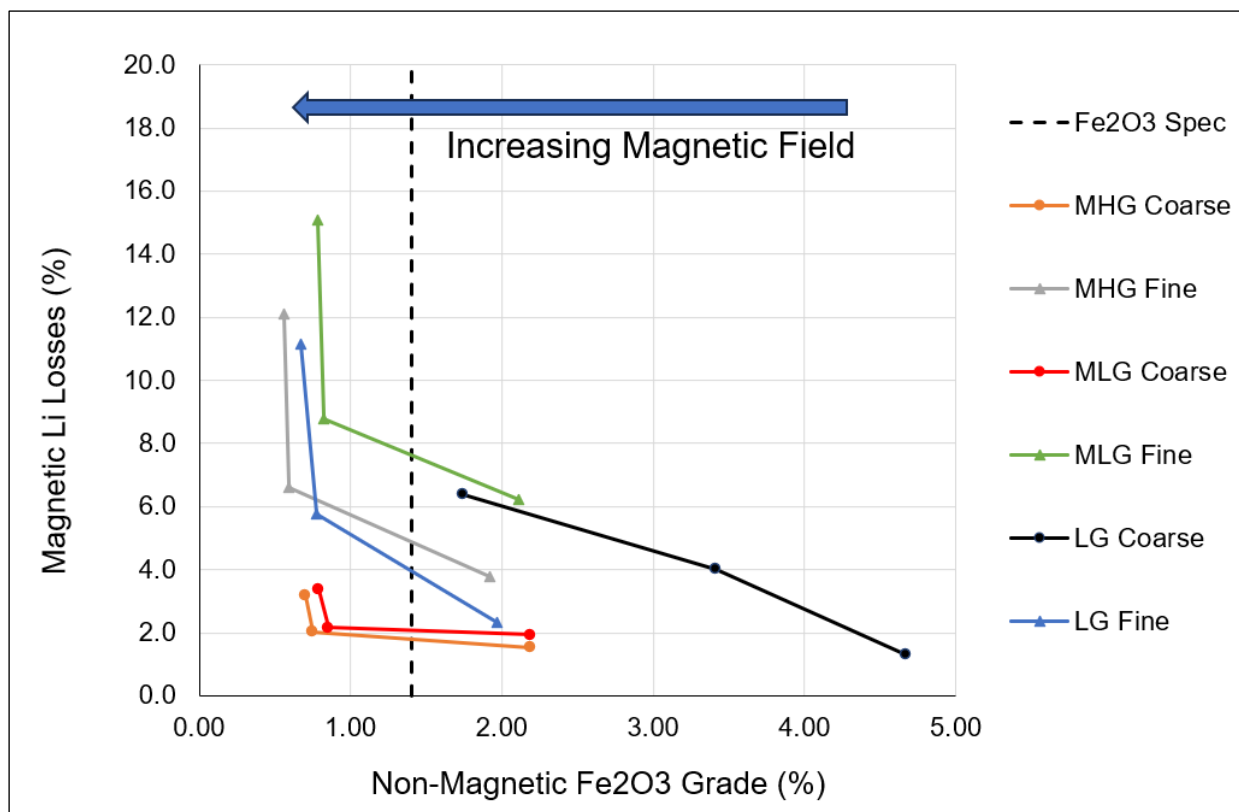

Figure 7: Dense Media Separation Concentrate Magnetic Response

Figure 1-8 shows that with increasing magnetic field strength, iron grades drop significantly, with a slight increase in lithium losses. Each composite was shown to be fully amenable to magnetic separation, with the combined final concentrate achieving an appropriate Fe<sub>2</sub>O<sub>3</sub> grade (<1.4%).

**1.8.1.5 Seymour Recovery**

The Seymour PEA DMS recovery was interpolated from the SRC and SGS testwork data, with adjustments made to account for staged laboratory HLS tests. Laboratory HLS achieves perfect separation, so a recovery discount may be applicable to reflect DMS operational performance and losses due to magnetic separation. The interpolated recovery curve for Seymour with respect to head grade is presented in Figure 7 together with HLS testwork recovery curve. Based on the LOM mine grade at 1.0% Li<sub>2</sub>O an interpolated 64.9% recovery is predicted.

A recovery of 65% has been used by GT1 for the PEA in acknowledgement of both upside to predicted recoveries as well as the recognition of losses when compared to perfect separation in HLS.

Further work around the impact of iron, mine dilution, hence magnetic separation performance is required to confirm lower grade ores can be treated to meet the iron grade limits being imposed in the concentrates and to undertake variability testwork on wider range of samples.

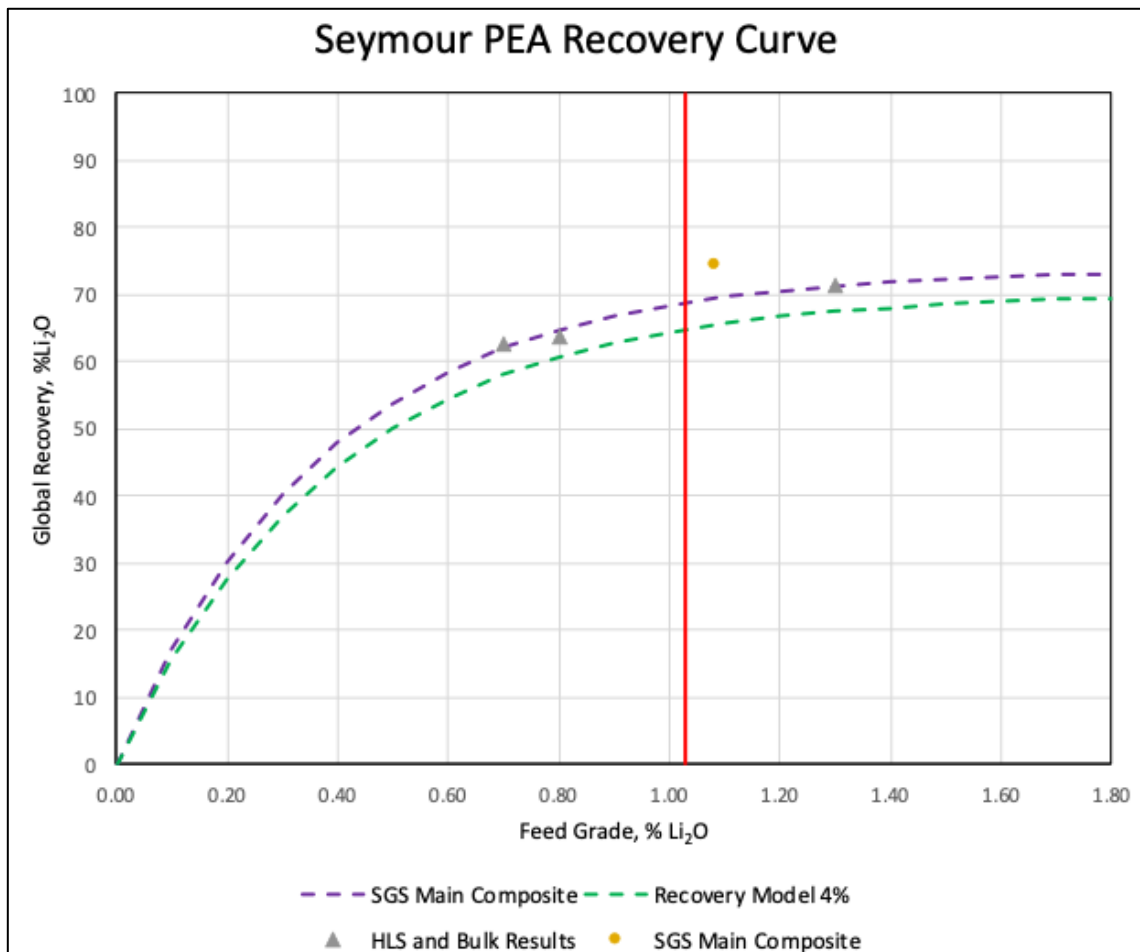

Figure 8: HLS Test Results (Purple curve) with Seymour Predicted Recovery (Green curve)

### 1.8.1.6 Seymour Testwork Conclusions

The conclusions from the Seymour testwork program are:

- Two stage gravity separation (DMS) at 2.85-2.90 (Stage 1) and 2.65 (Stage 2) will generate a lithium concentrate that with magnetic upgrade is saleable (5.5% Li<sub>2</sub>O and <1.4% Fe<sub>2</sub>O<sub>3</sub>)
- Operating with a coarse and fines parallel circuit is recommended. Tighter size distribution profiles improve DMS performance, with two sizes ranges being current commercial practices.
- HLS laboratory test results achieved concentrate grades from 6.5 - 6.8% for Li<sub>2</sub>O with a 60 - 71.7% recovery. Fe<sub>2</sub>O<sub>3</sub> was <1.0% after magnetic separation. After discounting the efficiency of DMS circuits and losses due to magnetics removal, recoveries could reduce by up to 10%. A 65% recovery was selected by GT1 for the PEA as described above.
- Reflux classification is recommended to be included as any step that reduces the contained mica is an operational risk mitigator.
- After an economic evaluation, the decision was taken to not include flotation as part of the flowsheet for the Seymour concentrator. Middlings and tailings materials will be stockpiled in such a way that future reprocessing could be considered.
- Additional work on ore zones as they are further defined by the mining team will be undertaken, with more variability composites being generated.

## Preliminary Economic Assessment

### 1.8.2 Root Concentrator Testwork

In 2023 a metallurgical testwork program was undertaken at SGS Mineral Services Lakefield (SGS) where 238 kg of footwall shoulder material (waste rock) and pegmatite were shipped for testing. Two composites were blended from this material and identified as:

- Pegmatite 10% dilution
- Pegmatite 30% dilution.

The samples tested at time of reporting do not represent the life of mine Root ore body. Future work will generate representative test samples to be tested with the flowsheet.

Lithia ( $\text{Li}_2\text{O}$ ) concentration in the pegmatite sample was 1.16% and the respective two composites had Lithia ( $\text{Li}_2\text{O}$ ) concentration of 0.95 % and 1.05% post blending of dilution material.

Standard Bond tests were conducted to determine grindability. The pegmatite had a Bond Ball Mill Work Index (BBWi) of 14.8 kWh/t, whereas the waste rock had a BBWi of 17.6 kWh/t. The Bond Rod Mill Work Index (BRWi) for the pegmatite was 13.4 kWh/t, while the waste rock had a BRWi of 19.8 kWh/t.

#### 1.8.2.1 HLS Laboratory Testwork

Initially, HLS testwork was performed on the basis of adopting a DMS only flowsheet similar to Seymour.

HLS laboratory test results confirmed that for the samples tested, a DMS crush size of <3.0mm would be required to achieve a concentrate grade of >5.5  $\text{Li}_2\text{O}$ , though recoveries would be considered low.

HLS testwork at various crush sizes was undertaken on both the 10% and the 30% diluted sample, achieving low recoveries at a 5.5%  $\text{Li}_2\text{O}$  grade.

The results demonstrate that a DMS only flowsheet is unlikely to be suitable for the Root ore, noting that the samples tested were not considered representative. A finer grind for the Root ores may be required. Future testwork will reveal whether the finer liberation size is a feature of the entire deposit or just an outlying property of the sample tested. The current flowsheet therefore uses a hybrid DMS with flotation flowsheet with a DMS top size of 3.3 mm, however a future opportunity would be to see if there is an advantage of considering a direct "only flotation" flowsheet.

#### 1.8.2.2 Flotation Testwork

A whole ore flotation sighter test program was subsequently undertaken with material being ground to  $P_{100}$  of 300 $\mu\text{m}$ , magnetically separated, mica removed via flotation, followed by an industrial standard spodumene flotation regime. The whole ore flotation testing, which has just begun, has achieved the following results for three tests:

- Concentrate grade of 5.5%  $\text{Li}_2\text{O}$ , <1.0%  $\text{Fe}_2\text{O}_3$  with a global lithium recovery of 53%
- Concentrate grade of 5.4%  $\text{Li}_2\text{O}$ , with a global lithium recovery of 68%
- Concentrate grade of 4.9%  $\text{Li}_2\text{O}$ , with a global lithium recovery of 64%

The variability in flotation performance was a function of the magnetic separation losses and losses in the cleaner stages of the flotation circuit and the effect of a coarser grind size than used in several existing operations.

Additional work is being undertaken based on the following:

- QEMSCAN and mineralogical analyses on samples to date are in progress to identify if there is a mineralogical cause which would shed light on the suboptimal flotation performance.
- Generate 3-4 variability samples which will represent the mine ore zones more accurately.
- Expand the flotation test program to improve performance via varying (reducing) grind size and the flotation regimes.
- Re-evaluation of HLS/DMS on the variability samples to confirm if technology should be included in the flowsheet.

**1.8.2.3 Root Recovery**

Based on the HLS results and the sighter flotation testwork performance, a recovery of 67.1% is predicted based on a 1.06% Li<sub>2</sub>O feed grade, to achieve the proposed concentrate grade of 5.5% Li<sub>2</sub>O and <1.4% Fe<sub>2</sub>O<sub>3</sub>, from a hybrid DMS with flotation plant flowsheet with a DMS top size of 3.3 mm.

Given that finer grind size performance and further variability testwork on representative samples may yield further opportunity, an overall plant recovery of 75% has been applied by GT1 for the PEA.

**1.8.3 Conversion Testwork**

A metallurgical testwork program is currently being undertaken at FLS, Utah during 2023. Two composite samples have been generated from the Seymour DMS testwork and these had Lithia (Li<sub>2</sub>O) concentration of 5.21% and 6.21%.

**1.8.4 Calcination Testwork**

A series of batch rotary kiln calcination tests were conducted, and results confirm that conversion is possible at temperatures ranging from 1050C – 1150°C, with conversion ranging from 96-99%, based on XRD analysis.

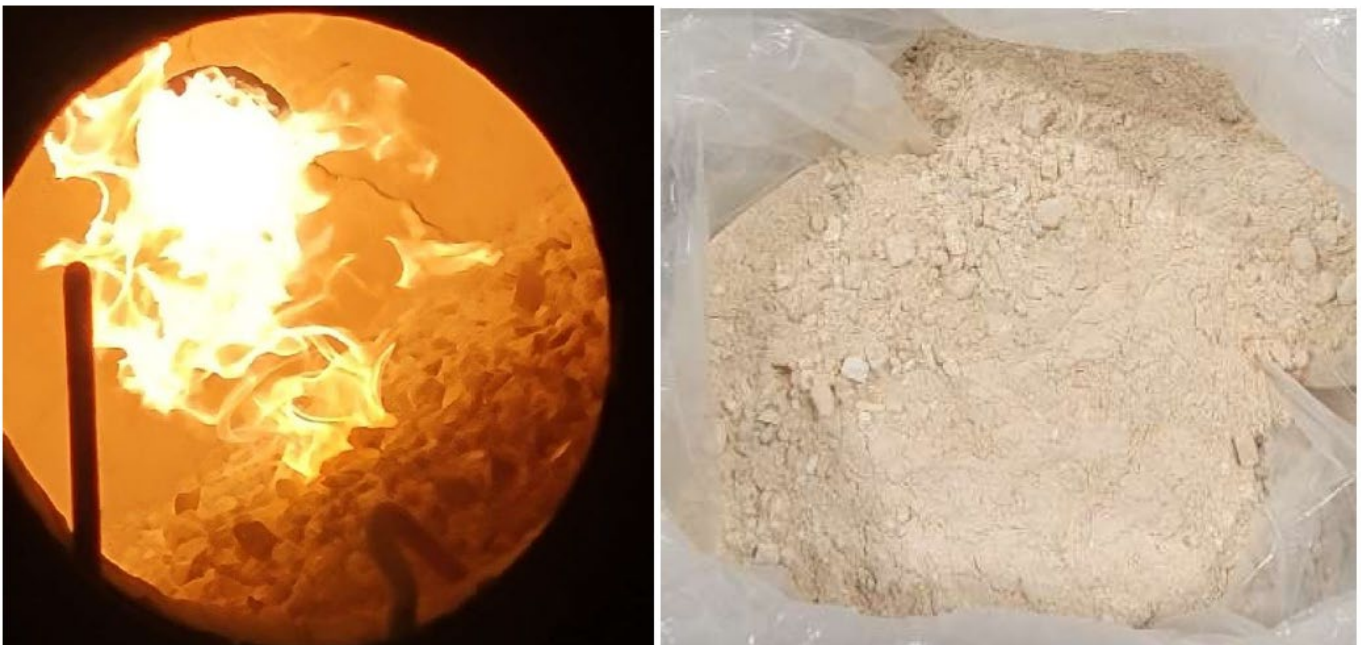

*Figure 9: Rotary kiln start (LHS) and end (RHS) bulk calcination test Comp 2*

The bulk calcination test was operated at the nominal 1050-1075°C for 60 minutes.

*Table 1-1 Calcination Bulk Test Results – Conversion %*

	Composite #1 - Conversion			Composite #2 - Conversion		
Sample Temp (°C)	15 min	30 min	Inventory	15 min	30 min	Inventory
1050 - 1075	98.4	97.9	98.6	97.4	97.3	98.0

**1.8.4.1 Leaching and Solubilisation testwork**

A series of twelve leach tests are in progress. Leach results at the time of reporting confirm the calcined material is amenable to carbonate leach, with test results achieving lithium solubilization (water soluble + acid soluble) ranging from 75% to 99%.

The conversion test to solubilize lithium carbonate to lithium hydroxide are pending and will be reported when completed. For the purposes of the PEA converter design a conversion facility recovery of 87% has been considered, whilst a conversion facility recovery of 92% has been used by GT1 for the PEA based on published information from conversion technology providers and other benchmark projects.

## 1.9 Mineral Resource Estimate

The MRE for the Project, representing in-situ lithium-bearing pegmatites, is reported below in accordance with the JORC 2012 Standards. GT1's MRE for the Seymour and Root Properties are reported by classification in Table 1-3 and Table 1-4 respectively.

**Table 11 – 3 June 2023 Seymour Mineral Resource Estimate Figures**

	Indicated			Inferred			Total		
Deposit	Tonnes (Mt)	Li <sub>2</sub> O (%)	Ta <sub>2</sub> O <sub>5</sub> (ppm)	Tonnes (Mt)	Li <sub>2</sub> O (%)	Ta <sub>2</sub> O <sub>5</sub> (ppm)	Tonnes (Mt)	Li <sub>2</sub> O (%)	Ta <sub>2</sub> O <sub>5</sub> (ppm)
North Aubry	6.1	1.25	149	2.1	0.8	108	8.3	1.13	139
South Aubry				2.0	0.6	91	2.0	0.60	91
<b>Total</b>	<b>6.1</b>	<b>1.25</b>	<b>149</b>	<b>4.2</b>	<b>0.7</b>	<b>100</b>	<b>10.3</b>	<b>1.03</b>	<b>129</b>
<ol style="list-style-type: none"> <li>1. Mineral Resource produced in accordance with the 2012 Edition of the Australian Code for Reporting of Mineral Resources and Ore Reserves (JORC 2012)</li> <li>2. Figures constrained to US\$4,000 open pit shell and reported above a 0.2% cut-off grade.</li> <li>3. Numbers in the mineral resource table have been rounded.</li> </ol>									

**Table 1-42 - September 2023 Root Mineral Resource Estimate Figures**

	Indicated		Inferred		Total	
Deposit	Tonnes (Mt)	Li <sub>2</sub> O (%)	Tonnes (Mt)	Li <sub>2</sub> O (%)	Tonnes (Mt)	Li <sub>2</sub> O (%)
McCombe	0	0	4.5	1.0	4.5	1.0
Root Bay	9.4	1.30	0.7	1.1	10.1	1.29
<b>Total</b>	<b>9.4</b>	<b>1.30</b>	<b>5.2</b>	<b>1.0</b>	<b>14.6</b>	<b>1.20</b>
<ol style="list-style-type: none"> <li>1. Mineral Resource produced in accordance with the 2012 Edition of the Australian Code for Reporting of Mineral Resources and Ore Reserves (JORC 2012)</li> <li>2. Figures constrained to US\$4,000 open pit shell and reported above a 0.2% cut-off grade.</li> <li>3. Numbers in the mineral resource table have been rounded.</li> </ol>						

Exploratory data analysis was undertaken for each of the data sets and sub-domains created where required. Data was composited to 1m composite downhole to geological contacts. Top cuts were applied where necessary, typically around the 99<sup>th</sup> percentile. No top cuts were applied at McCombe but high-grade clamping was applied to the estimates to minimize the impact to the estimate of extreme values. Multiple pass estimates were made for all deposits using an ordinary kriging algorithm. Each block model was validated in several ways, including visual inspection in plan and cross section comparing block estimates to composite values, swath plots and model and composite statistical comparison. Each MRE was classified according to drill spacing, block estimation parameter including kriging variance, number of composites in the search ellipsoid informing the block cell and average distance of data to the block centroid.

Average bulk density values measured using the water immersion technique were applied to Seymour pegmatites (2.78), McCombe pegmatites (2.70) and Root Bay pegmatites (2.72) and varying average bulk densities applied to other rock types within the models.

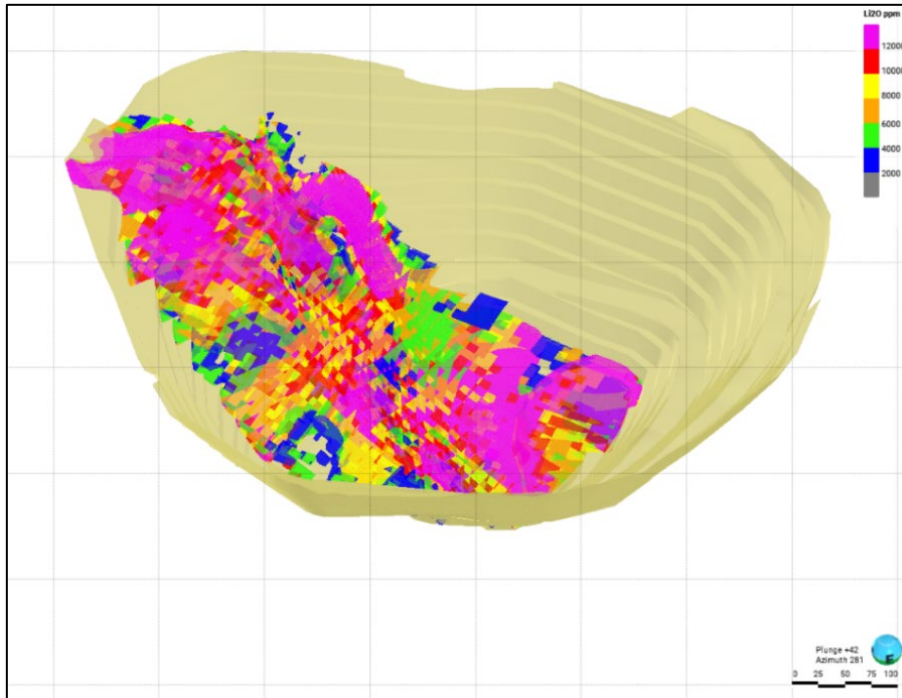

Figure 10: Oblique view North Aubry Block Model and pit design

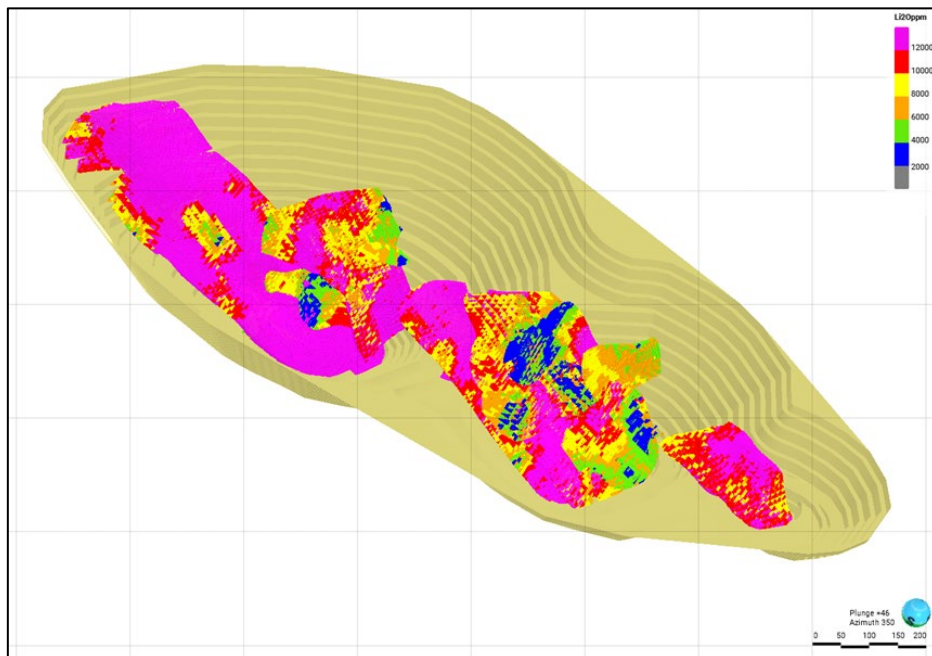

Figure 11: Oblique view Root Bay Block Model and pit design

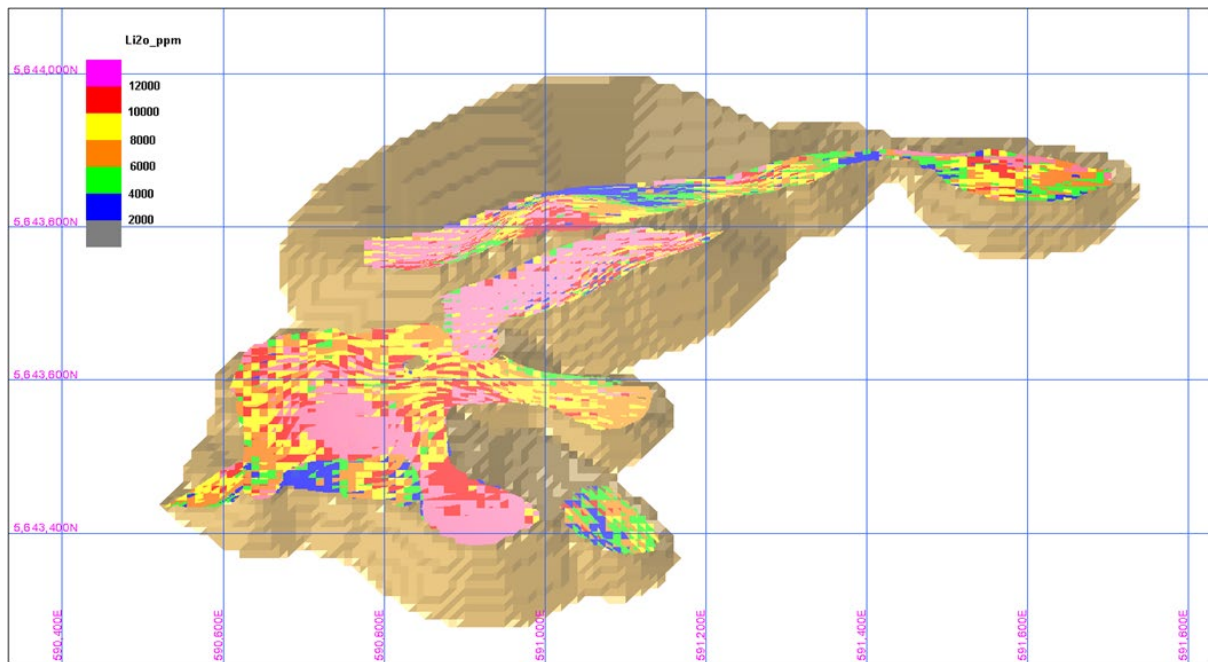

Figure 12: Oblique view McCombe Block Model and pit design

## 1.10 Ore Reserve Estimates

The PEA referred to in this report is based on low-level technical and economic assessments and is insufficient to support estimation of Ore Reserves or to provide assurance of an economic development case at this stage, or to provide certainty that the conclusions of the PEA will be realised.

## 1.11 Mining Methods

### 1.11.1 Production Target

GT1 engaged Entech Pty Ltd (Entech) to undertake a PEA for their Seymour Lithium Project (“Aubry North & South”) and their Root Lithium Project (Root Bay + McCombe).

The Mineral Resource Models supplied by GT1 were prepared for open pit optimisation by adding cost, recovery, royalties, and revenue drivers to individual blocks within the model using Surpac macros. A Net Smelter Return (NSR) value for spodumene concentrate was calculated using these inputs. The use of Surpac macros provides an audit trail and facilitates checking assigned optimisation parameters. Royalties, administration charges, feed material mining costs and feed material haulage are all aggregated to create a total feed material related cost assigned to feed material blocks.

Fields written to the model include:

- MCAF – Mining cost adjustment factor, material specific mining costs which include:
  - drill and blast, load and haul and mining overheads, and
- PCAF – Processing cost adjustment factor, material specific processing costs which include:
  - general and administration, grade control, surface haulage to mill and any additional royalties.

The PEA referred to in this report is based on low-level technical and economic assessments and is insufficient to support estimation of Ore Reserves or to provide assurance of an economic development case at this stage, or to provide certainty that the conclusions of the PEA will be realised.



## Preliminary Economic Assessment

### 1.11.2 Mineral Resource Model

The four geological models used in this study were provided to Entech by GT1:

- North Aubry – (“*bm\_seymour nth aubry jun2023.dm*” (2.5GB), June 2023)
- South Aubry – (“*bm\_seymour Sth Aubry Jun2023.dm*” (350MB), June 2023)
- McCombe – (“*BM\_Draft\_McCombe 20230316.dm*” (12GB), March 2023)
- Root Bay – (“*bm root bay 230926\_opt2 eng.dm*”(750MB), September 2023)

The Mineral Resource block model inventories are provided in section 1.9 Mineral Resource Estimate, all reports are constrained by a Li<sub>2</sub>O cut-off above 0.2%. This cut-off value was determined based on revenue and processing information provided by GT1, and mining costs from Entech database.

### 1.11.3 Mining Methods

#### 1.11.3.1 Geotechnical Setting

Entech was commissioned by GT1 to undertake geotechnical studies, specifically to evaluate the potential for slope instabilities and derive slope design parameter recommendations for the proposed open cut mining of North Aubry deposit within the wider Seymour Project, and Root Bay deposit within the Root Project. Some preliminary geotechnical analysis was conducted at McCombe and Root Bay deposits, however due to time constraints the results from North Aubry have been applied to works carried out on the McCombe and Root Bay resource models.

The work program conducted by Entech consisted of the following:

- Data collection, validation, and analysis through rock mass and structure characterisation and modelling.
- Pit design through empirical and limit equilibrium analysis.
- Reporting results and recommendations.

The following information was also made available for this study:

- Complete drill hole database.
- Lithology (limited to Pegmatite), and pit optimisation wireframes.
- Pit optimisation wireframes.

Physical logging of diamond drill core was undertaken to investigate ground conditions specific to North Aubry. A total of eight diamond drill holes, located in the vicinity of the proposed North Aubry pit walls and totalling 2,493 m, were used for the collection of detailed geotechnical data, including rock mass and structure characterisation, and oriented structure data. The geotechnical data collection program for North Aubry was conducted by Entech in August and October 2022.

A dedicated geotechnical material properties testing program was designed by Entech to capture information pertinent to characterising and understanding the mechanical behaviour of the different materials expected to be encountered at North Aubry, and to form a basis for input to slope stability analysis. The geotechnical material properties testing program for North Aubry was conducted by Geomechanica Laboratory in September 2022.

Photo logging of diamond drill core was undertaken to investigate ground conditions specific to Root Bay. A total of eight diamond drill holes, located in the vicinity of the proposed Root Bay pit walls and totalling 1,550 m, were used for the collection of detailed geotechnical data, including rock mass and structure characterisation. The geotechnical data collection program for Root Bay was conducted by Entech in September 2023.

The confidence of the geotechnical data for North Aubry is considered to be Pre-Feasibility Study level. The confidence of the geotechnical data for Root Bay is considered to be PEA level. Although Root Bay has a lower confidence level of

geotechnical data compared to North Aubry, it is anticipated that Root Bay will have upside design parameters similar to North Aubry with additional geotechnical data and further design analysis.

### 1.11.3.2 Hydrogeology and Surface Hydrology

Hydrogeology and surface hydrology studies have been undertaken in parallel to the current mining study and were not available to be incorporated into the mine optimisation at this stage.

### 1.11.3.3 Design Analysis

Slope design modelling and analysis was undertaken, including kinematic and limit equilibrium slope stability, to develop the slope design parameter recommendations.

Entech adopted the Slope Design Acceptance Criteria outlined within the publication, Guidelines for Open Pit Slope Design (Read & Stacey, 2009).

Kinematic analysis indicated that the probability of any of the three batter-scale failure modes (planar, wedge and toppling) occurring on all pit walls at a bench face angle of up to 85° is generally low to moderate and within the acceptable limits of design.

The limit equilibrium slope stability analysis indicated that slope instability at an inter-ramp or overall (pit) scale is unlikely within the slope design parameter recommendations.

### 1.11.3.4 Slope Design Parameters

Due to the rockmass conditions and proximity of the Top of Fresh (TOFR) to surface, a single geotechnical domain has been applied at North Aubry. Based upon the analysis contained within this report, the slope design parameter recommendations that have been developed are provided in .

**Table 1-53 - Slope Design Parameters**

Domain	Material	Bench Height (m)	Bench Face Angle (°)	Spill Berm Width (m)	Overall Slope Angle (°)
North Aubry	Mafic	20	75	9	52
	Metasediments	20	75	9	52
Root Bay	Overburden	10	30	6	23
	Fresh (recommended)	20	70	10	49
	Fresh (upside) <sup>1</sup>	20	75	9	52

Notes:

<sup>1</sup>The confidence of the geotechnical data for Root Bay is considered to be PEA level. Although Root Bay has a lower confidence level of geotechnical data compared to North Aubry, it is anticipated that Root Bay will have upside design parameters similar to North Aubry with additional geotechnical data and further design analysis.

A bench-stack height of 100m/five benches is recommended in fresh rock. A geotechnical berm of 12m width is recommended to separate bench-stacks to decouple the long and steep pit walls and to flatten the overall slope angle. The requirement for geotechnical berms may be reassessed depending on the location of access ramp passes.

The pit crest end of mine life bund-wall was offset 40m from the pit crest.

### 1.11.3.5 Pit Optimisation and Design

Open pit optimisation is a process of selecting the most profitable open pit shell that matches the risk profile for a company. Risk can be managed using a variety of methods, such as using a conservative commodity price, increasing the profit margin or by selecting a smaller pit than the one that generates the maximum value. Despite optimisation results

generating larger net present value (NPV) pit shells, by applying this selection criterion, so long as a sufficient mill feed can be maintained, then a more generous monthly net cash flow can be maintained.

Mining and Drill & Blast costs were estimated by Entech. These mining costs were finalised after benchmarking values against recent Canadian & American mining studies supplied by Green Technology Metals.

Green Technology Metals supplied assumptions and modifying factors for revenue/marketing and processing.

Pit optimisation inputs can be seen in Table 1-6 - Optimisation Inputs and Parameters

**Table 1-64 - Optimisation Inputs and Parameters**

Description	Unit	Seymour Values	Root Bay Values	McCombe Values
Mining Recovery	%	95	95	95
Mining Dilution	%	10	10	10
Spodumene Concentrate (5.5)	USD \$/t	2,500	2,500	2,500
Processing Cost	CAD \$/t	48.87	50.07	53.19
Mining G&A	CAD \$/t	10.57	10.57	10.57
Annual Discounting	%	8	8	8
Process Recovery	%	65	75	75
Drill and Blast	CAD \$/bcm	2.74	2.74	2.74
<b>Load &amp; Haul</b>				
Feed material Surface Cost - increment by \$0.14 every 5m (vertical)	CAD \$/bcm	11.06	11.06	11.06
Waste Surface Cost - increment by \$0.21 every 5m (vertical)	CAD \$/bcm	9.24	9.24	9.24
Process Rate	Mtpa	1.5	1.5	
Mining Rate (Total Rock)	Mtpa	34	35	

Pit optimisations were carried out using a fixed spodumene product price for a 5.5% lithium oxide concentrate and a fixed processing recovery. The formula's used to determine the product mass of spodumene concentrate are as follows:

$$Product (DMS + Float) = ((Li2O\_ppm/1,000,000) * processing\ recovery(75\%))/grade(5.5\%)$$

$$Product (DMS) = ((Li2O\_ppm/1,000,000) * processing\ recovery(65\%))/grade(5.5\%)$$

Whittle pit optimisation software was used to identify the preferred pit shells on which the pit designs were based. The three separate mining models assessed represent spatially discrete mining locations. The analysis of these optimisation processes showed that the four mining models produced pit shells of a suitable size and satisfied sufficient criteria to progress to pit design.

Each candidate shell was subjected to a high-level review, considering factors such as discounted operating surplus, Production Target, suitability for the proposed mining method in collaboration with Green Technology.

Waste volumes are listed in Table 1-7- Waste Rock Volumes.

*Table 1-75 - Waste Rock Volumes*

<b>Pit Waste Inventories + Swell (1.2)</b>			
<b>Location</b>	<b>Rock</b>	<b>Units</b>	<b>Volume</b>
North Aubry Pit Design	Waste	Mbcm	40
South Aubry Pit Design	Waste	Mbcm	5.8
Seymour Total	Waste	Mbcm	46
<b>Seymour Total (+20% Swell)</b>	<b>Waste</b>	<b>Mlcm</b>	<b>55</b>
Root Bay	Waste	Mbcm	90
<b>Root Bay Total (+20% Swell)</b>	<b>Waste</b>	<b>Mlcm</b>	<b>110</b>
McCombe	Waste	Mbcm	29
<b>McCombe Total (+20% Swell)</b>	<b>Waste</b>	<b>Mlcm</b>	<b>35</b>

All proposed open pit designs and Whittle shells that form the Production Target scheduling and reporting, were provided to Green Technology’s technical personnel for review and feedback prior to finalising a first pass mining schedule.

Pit design assumptions used for North, South Aubry and McCombe pits are listed in table below:

*Table 1-86 - Design Assumptions*

<b>Design Assumptions</b>	
Truck Size (t)	100
Ramp Widths (m) - Dual Lane	26
Ramp Widths (m) - Single Lane	18
Ramp Gradient (%)	10
Bench Height (m)	20
Bench Width (m)	9
Bench Face Angle (°)	75

Differences in outcomes relating to the mined volumes, production target and overall stripping ratios can often be realised when progressing from the optimisation phase to a mine design phase. These discrepancies typically arise from the practicalities of pit ramp placement, additional geotechnical considerations during the design phase and the overall strike length and extents of the proposed open pit design.

All reported values have had a mining recovery of 95% and a dilution factor of 10% applied. These values have been used for scheduling and cost modelling.

A comparison between the outcomes of the selected Whittle shells and proposed open pit designs can be seen in Table 1-9 to Table 1-12.

**Table 1-97 - Optimisation Shell to Pit Design – North Aubry**

<b>North Aubry Pit Report (cut-off Li<sub>2</sub>O&gt;0.2%)</b>					
<b>Summary</b>	<b>Units</b>	<b>Whittle Shell</b>		<b>Pit Design</b>	<b>Delta</b>
Feed material	Mt	5.6		5.5	98%
Waste	Mt	104		120	115%
Total Rock	Mt	110		130	118%
Strip Ratio		18		21	117%
Li <sub>2</sub> O	Kt	67		66	98%
Li <sub>2</sub> O	Ppm	12,000		12,000	100%
Concentrate (5.5)	Kt	790		780	99%

Notes: All tonnages and grades have been rounded to reflect the relative uncertainty of the estimate, thus sum of columns may not equal. Mining recovery and dilution has been applied to all reported values.

**Table 1-108 - Optimisation Shell to Pit Design – South Aubry**

<b>South Aubry Pit Report (cut-off Li<sub>2</sub>O&gt;0.2%)</b>					
<b>Summary</b>	<b>Units</b>	<b>Whittle Shell</b>		<b>Pit Design</b>	<b>Delta</b>
Feed material	Mt	2.0		1.9	95%
Waste	Mt	14		17	121%
Total Rock	Mt	16		18	118%
Strip Ratio		7		9	128%
Li <sub>2</sub> O	kt	12		10	83%
Li <sub>2</sub> O	ppm	5,800		5,600	97%
Concentrate (5.5)	kt	140		120	86%

Notes: All tonnages and grades have been rounded to reflect the relative uncertainty of the estimate, thus sum of columns may not equal. Mining recovery and dilution has been applied to all reported values.

Root Bay deposit was not taken to pit design stage due to time constraints, instead the GEOVIA Whittle shell selected was used to define the mining schedule inventory for this study.

**Table 1-119 - Optimisation Shell to Pit Design – Root Bay**

<b>Root Bay Pit Report (cut-off Li<sub>2</sub>O&gt;0.2%)</b>					
<b>Summary</b>	<b>Units</b>	<b>Whittle Shell</b>		<b>Pit Design</b>	<b>Delta</b>
Feed material	Mt	10		-	-
Waste	Mt	218		-	-
Total Rock	Mt	228		-	-
Strip Ratio		21.8		-	-
Li <sub>2</sub> O	kt	110		-	-
Li <sub>2</sub> O	ppm	12,000		-	-
Concentrate (5.5)	kt	1,600		-	-

Notes: All tonnages and grades have been rounded to reflect the relative uncertainty of the estimate, thus sum of columns may not equal. Mining recovery and dilution has been applied to all reported values. The Root Bay optimised shell did not proceed to the pit design stage due to time constraints.

Table 1-1210 - Optimisation Shell to Pit Design - McCombe

McCombe Pit Design Report (cutoff Li <sub>2</sub> O>0.2%)				
Summary	Units	Whittle Shell	Pit Design	Delta
Feed material	Mt	3.7	3.4	92%
Waste	Mt	86	99	115%
Total Rock	Mt	90	100	114%
Strip Ratio		23	29	125%
Li <sub>2</sub> O	Kt	36	33	92%
Li <sub>2</sub> O	Ppm	9,600	9,600	101%
Concentrate (5.5)	Kt	490	450	92%

Notes: All tonnages and grades have been rounded to reflect the relative uncertainty of the estimate, thus sum of columns may not equal. Mining recovery and dilution has been applied to all reported values.

### 1.11.3.6 Mine Scheduling

A life of mine (LOM) schedule was developed in GEOVIA MineSched software using the physical quantities reported from the optimised pit designs.

Seymour and Root were scheduled independently but were combined in the cost model as the start of Root is dependent on Seymour and maintaining the 1.5Mt per annum product feed. In both schedules the mining fleet configuration was influenced by the production rate, mill throughput, strip ratio and the extents of the proposed open pits.

At Seymour two mining excavators were selected to make up the mining fleet, a 250 t Fleet to prioritise bulk waste movement and another 250 t excavator to focus on mining feed material. One of the 250 t excavator will remove most of the waste in each pit before moving to the next pit stage leaving the other 250 t excavators to follow behind to remove the remaining feed material. Occasionally the production rates will be limited by bench turn over and limited working space at depth. Once North Aubry is mined only one excavator is required to complete the smaller South Aubry open pit.

A mining fleet production target of 35 Mt per annum has been applied in conjunction with a 1.5 Mt per annum processing target.

A 4-month pre-stripping campaign has been scheduled prior to the Mill start-up date. During this time the mining fleet will work North Aubry removing waste that will be used where possible for onsite construction. The Concentrator will then commence production after the four months of pre-stripping is complete.

The concentrator has a six month ramp up period before reaching its full capacity of 1.5Mt per annum.

While North Aubry is supplying feed material to the mill the average grade of Li<sub>2</sub>O is above 1.2%. Once North Aubry feed material is complete the average Li<sub>2</sub>O grade falls to 0.6% and will require blending on the ROM.

At its peak production Root Bay project requires three 250 t mining excavators to maintain Mill feed of 1.5Mt per annum. One excavator is required to prioritise waste movement and another 250 t excavator to focus on mining feed material a third excavator is introduced later in the schedule for approximately 2 years where additional waste is required to be moved. Once this additional waste has been removed the third excavator is no longer required. Occasionally the production rates will be limited by bench turn over and limited working space at depth.

As Seymour nears completion, Root will begin the ramp up in production to meet and maintain the 1.5 Mt per annum of product feed. The concentrator ramp up due to flotation is longer and planned at 9 months before full production.

Figure 13 shows the scheduled Concentrator feed, starting in Year 1, then ramping up to maximum feed of 1.5Mt per annum. The chart shows the feed material coloured by mining location, North Aubry, South Aubry, Root Bay and then McCombe.

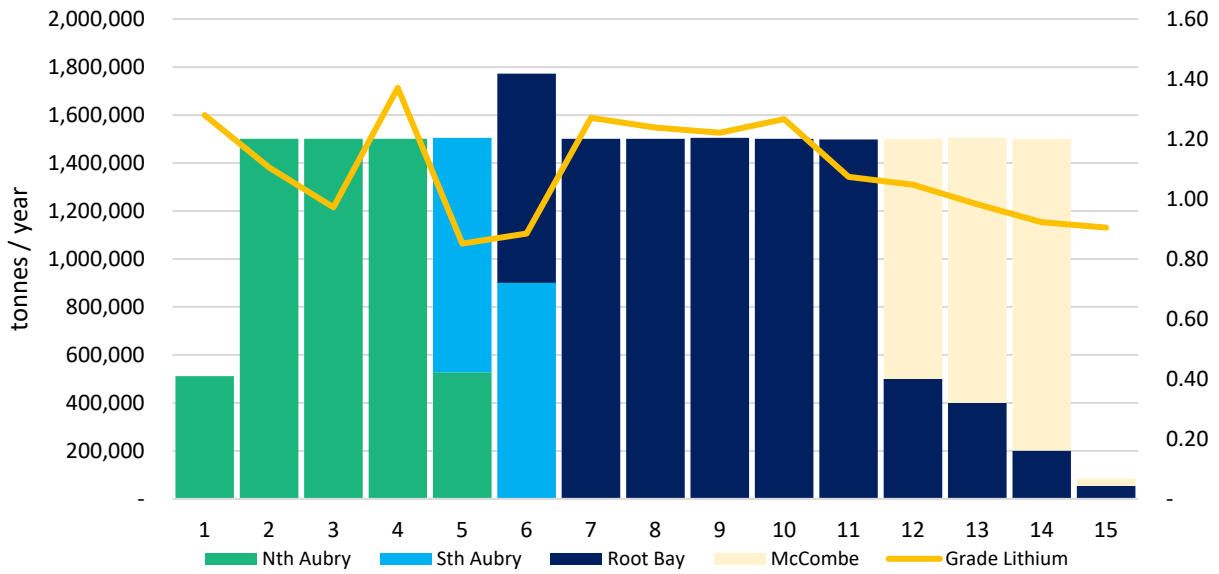

Figure 13 - Schedule Results - Yearly Feed material added to Process

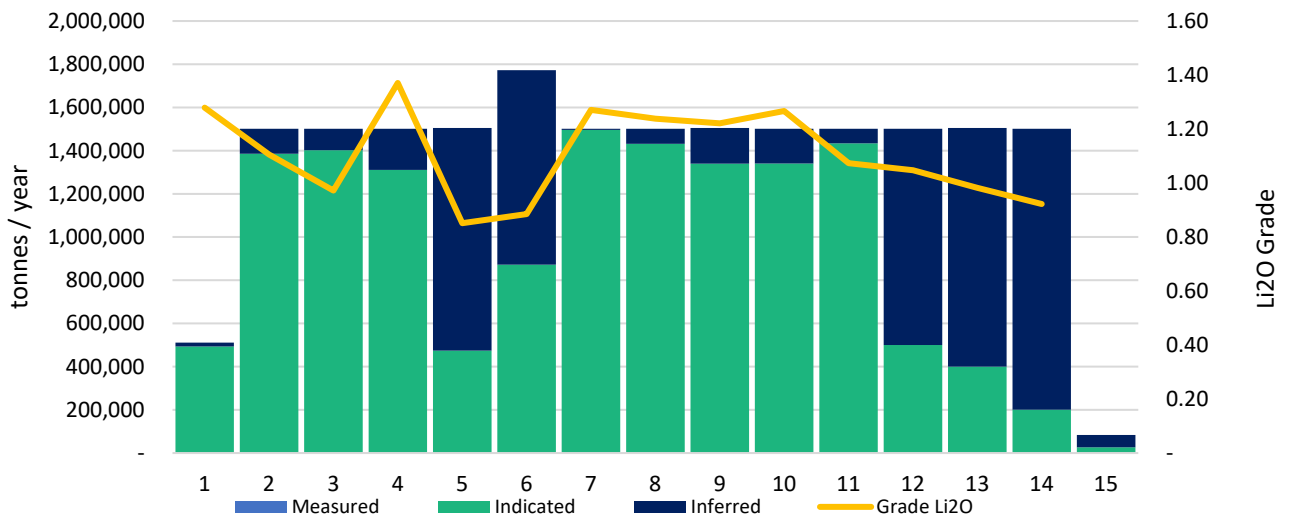

Figure 14 - Yearly Processed Feed Material by Resource Category

Long sections of the proposed open pit designs for North Aubry, South Aubry, Root Bay and McCombe are illustrated in Figure 13 through Figure 24 .

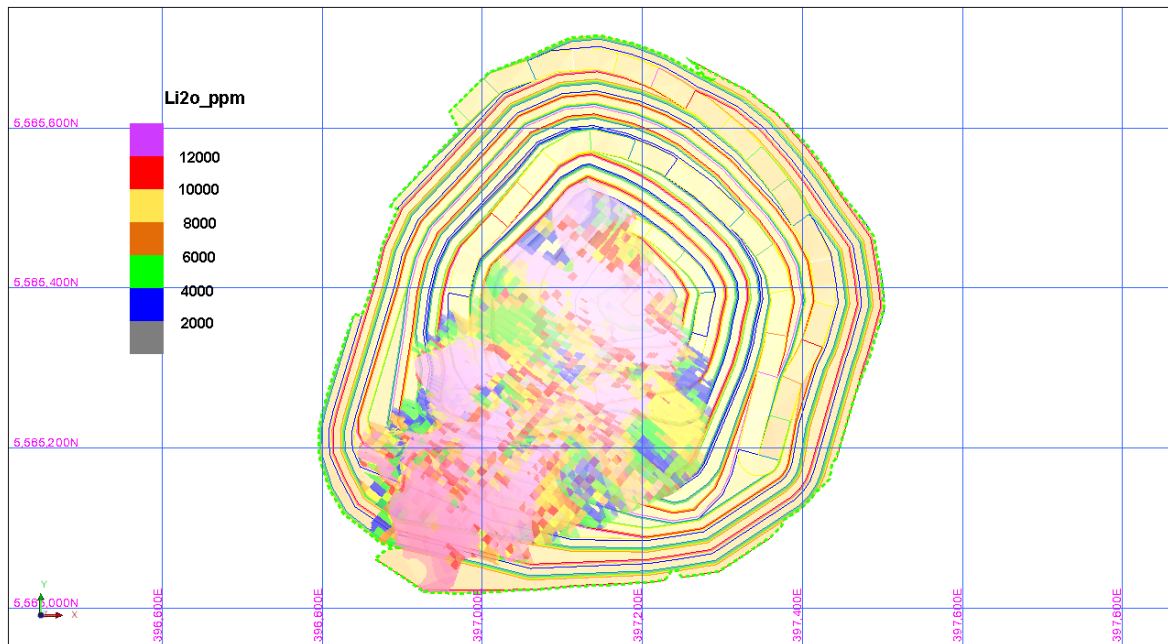

Figure 13: Plan View of Proposed Pit Design - North Aubry

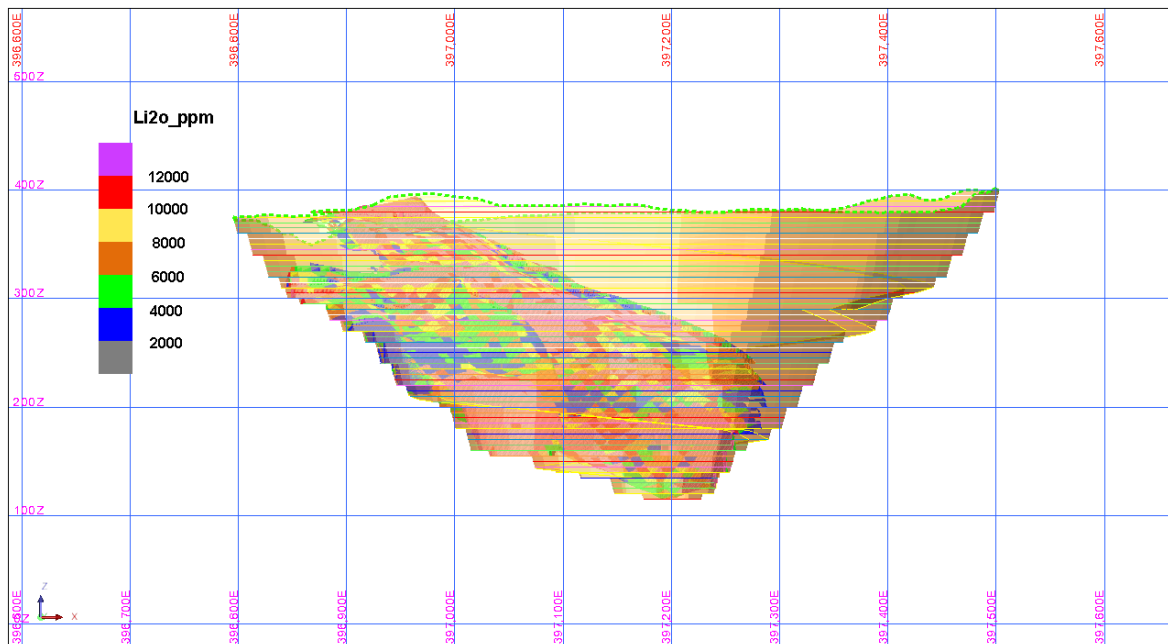

Figure 14: Section View of Proposed Pit Design - North Aubry



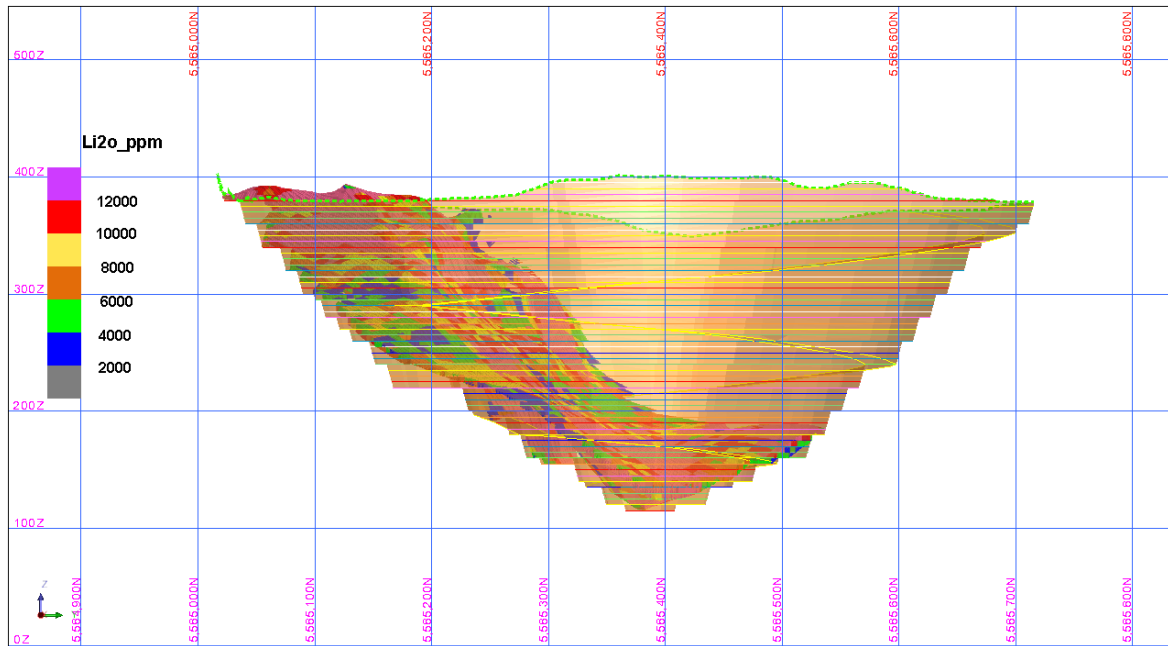

Figure 15: Long Section View of Proposed Pit Design - North Aubry

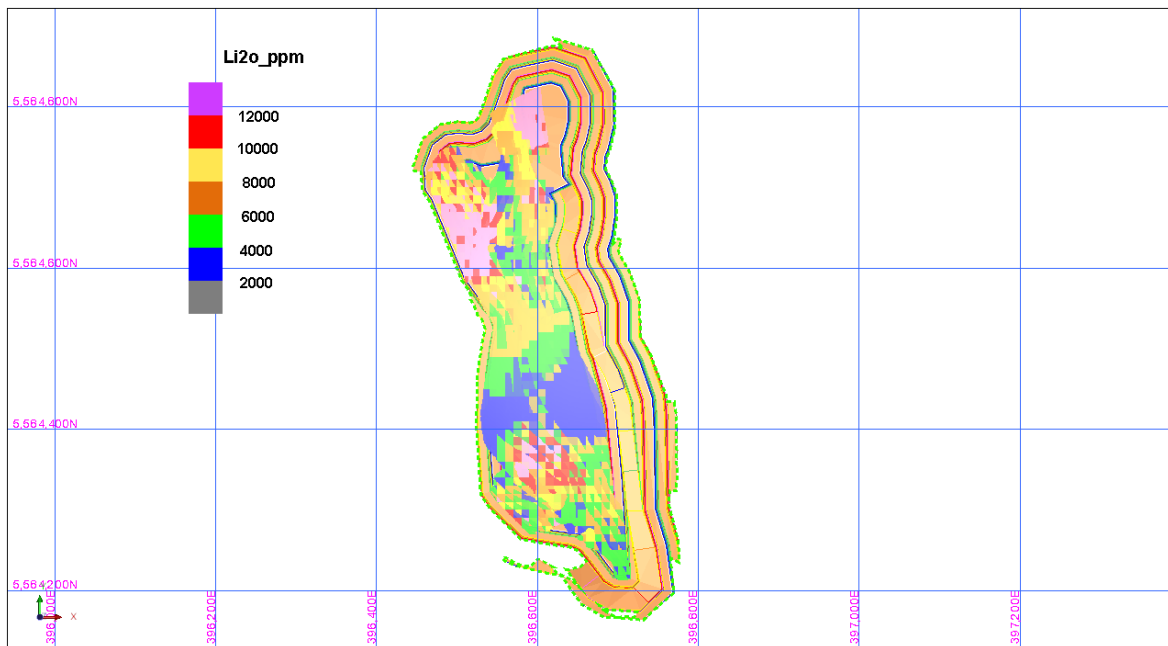

Figure 16: Plan View of Proposed Pit Design - South Aubry

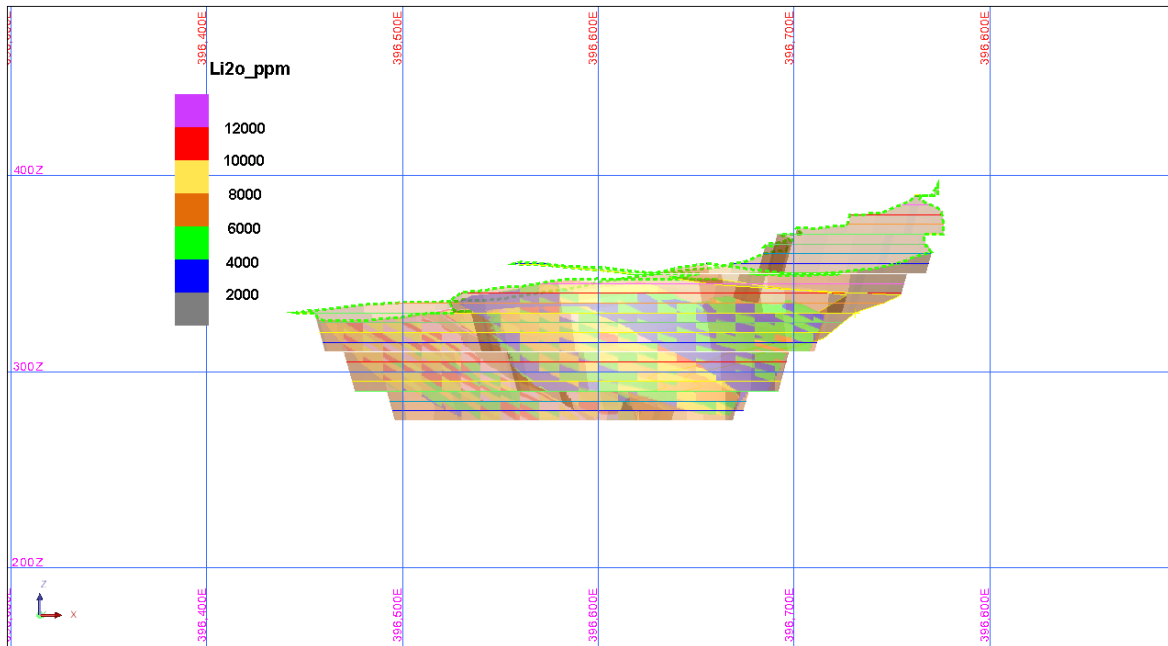

Figure 17: Section View Proposed Pit Design - South Aubry

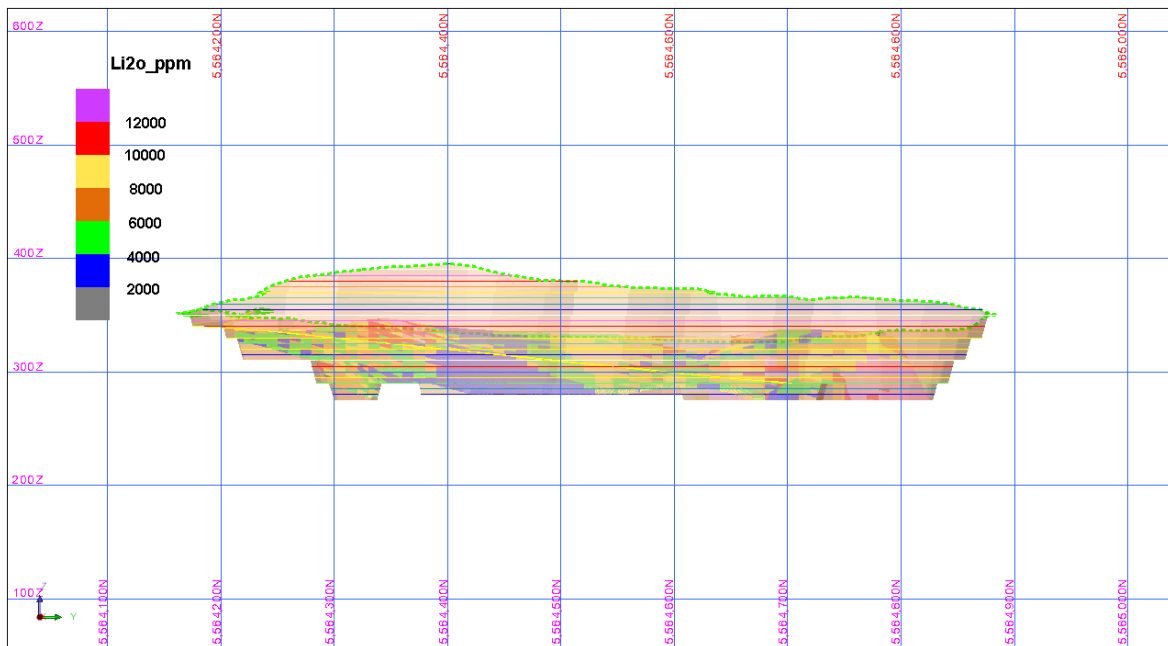

Figure 18: Long Section of Proposed Pit Design - South Aubry

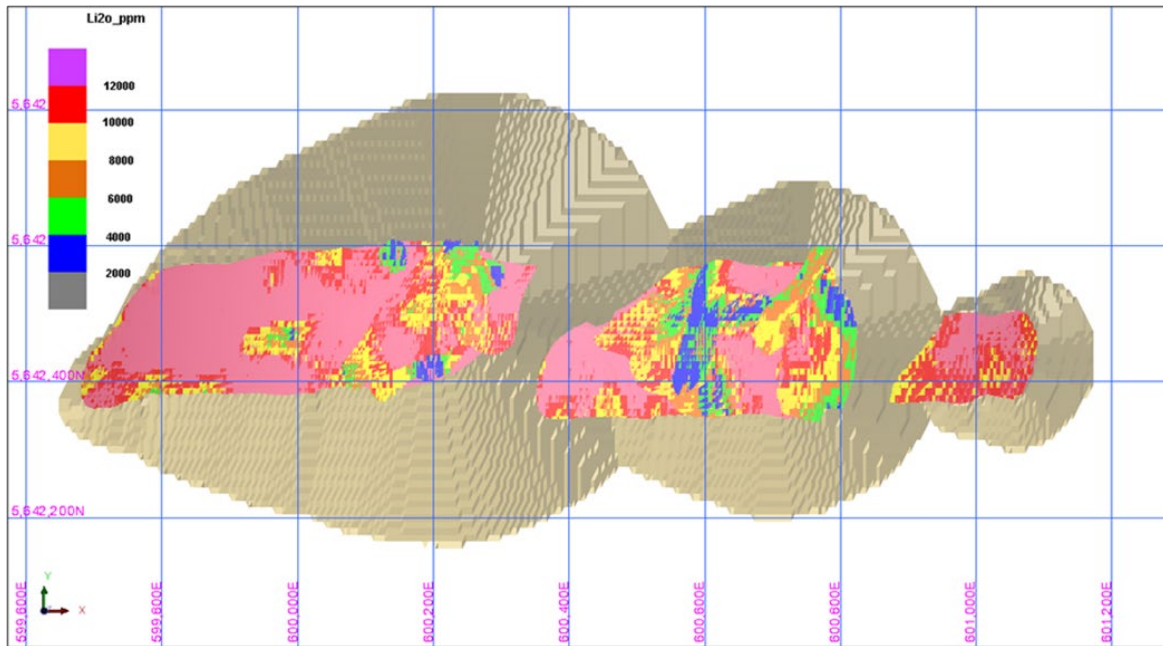

Figure 19: Plan View of Proposed Pit Shell - Root Bay

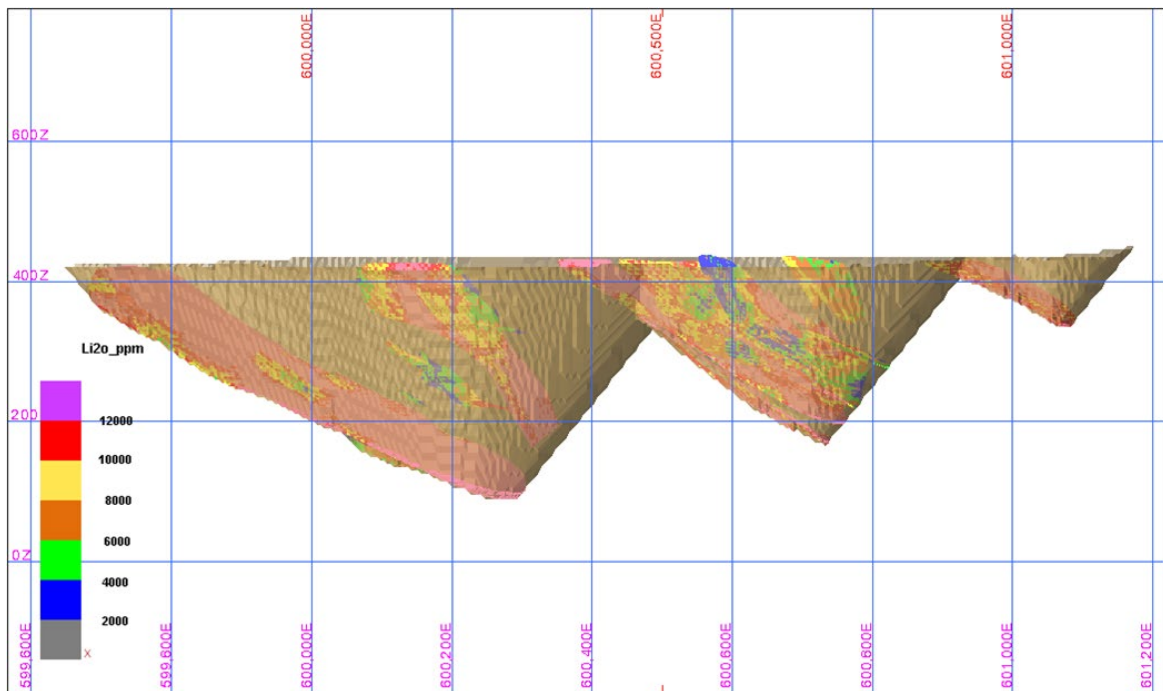

Figure 20: Section View of Proposed Pit Shell for Root Bay

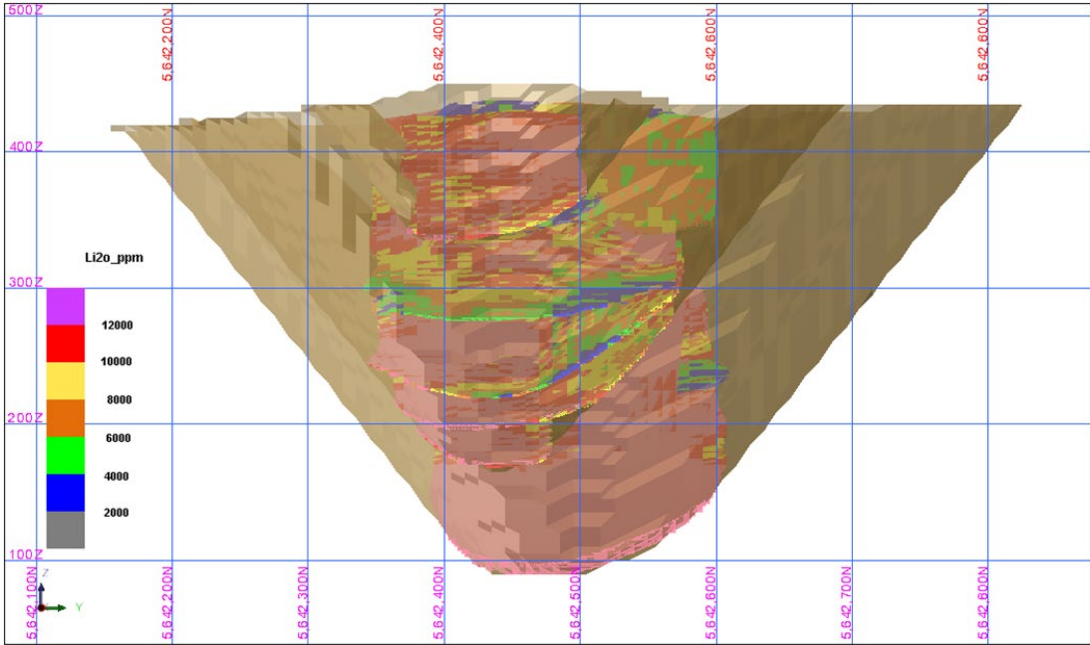

Figure 21: Long Section View of Proposed Pit Shell for Root Bay

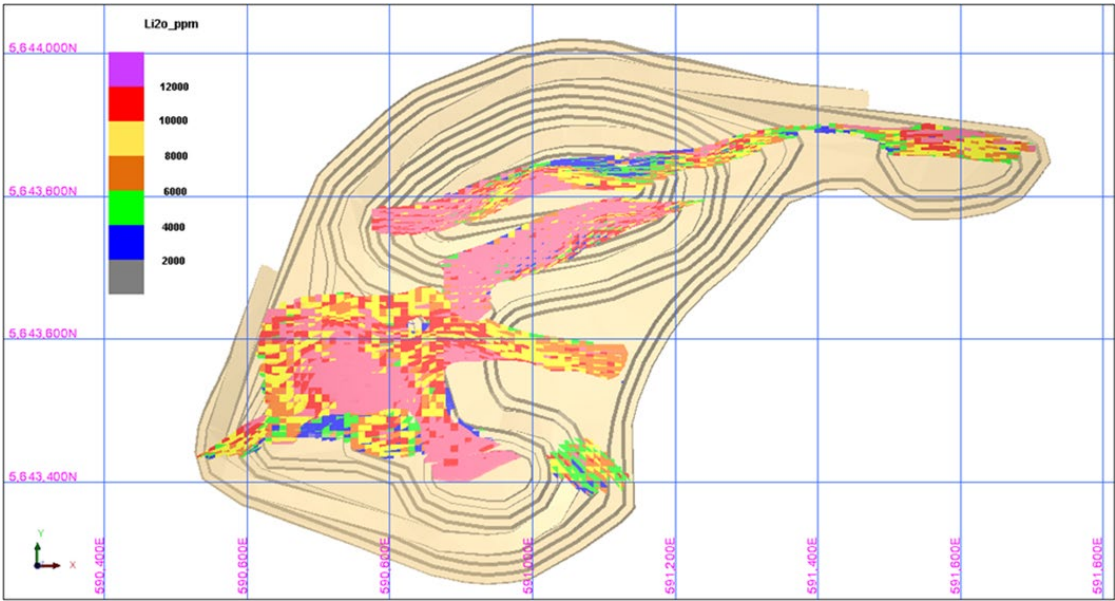

Figure 22: Plan View of Proposed Pit Design - McCombe

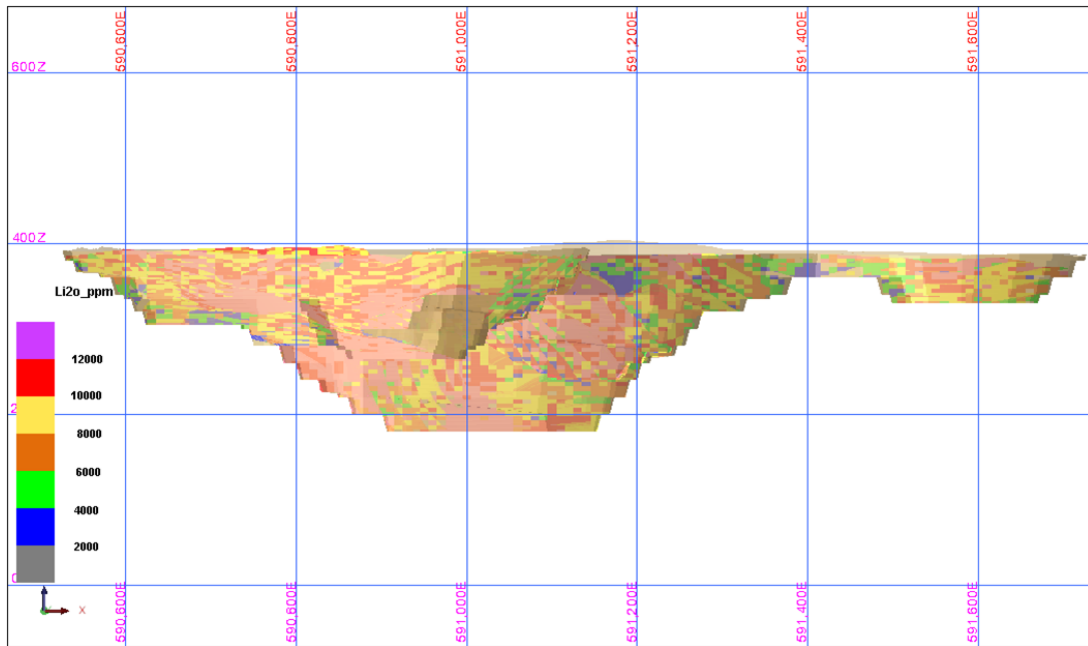

Figure 23: Section View of Proposed Pit Design – McCombe

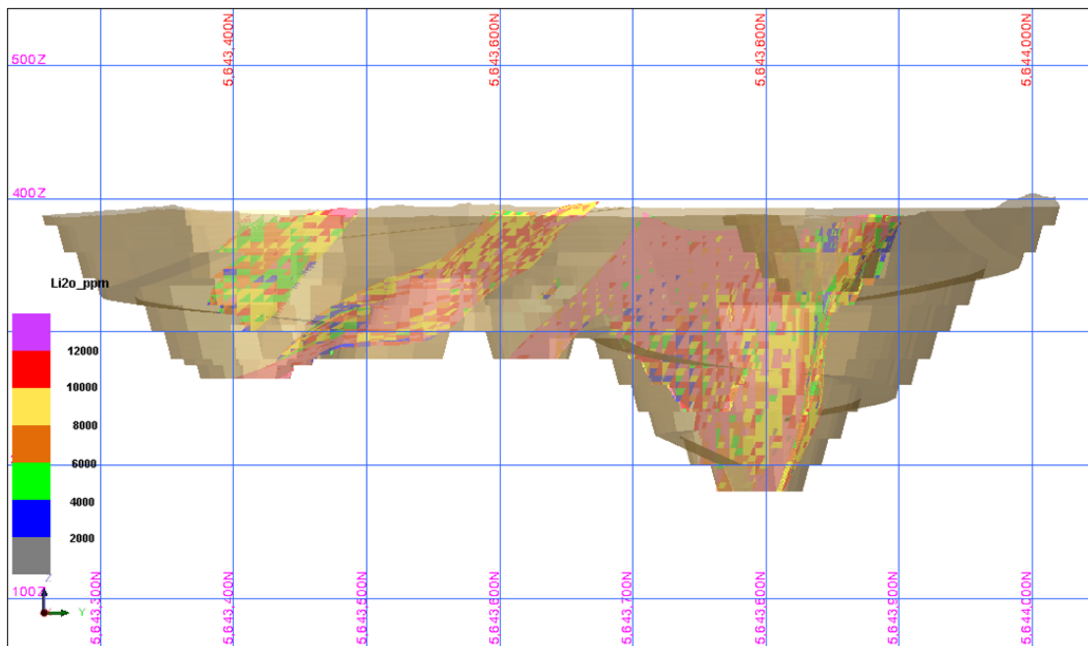
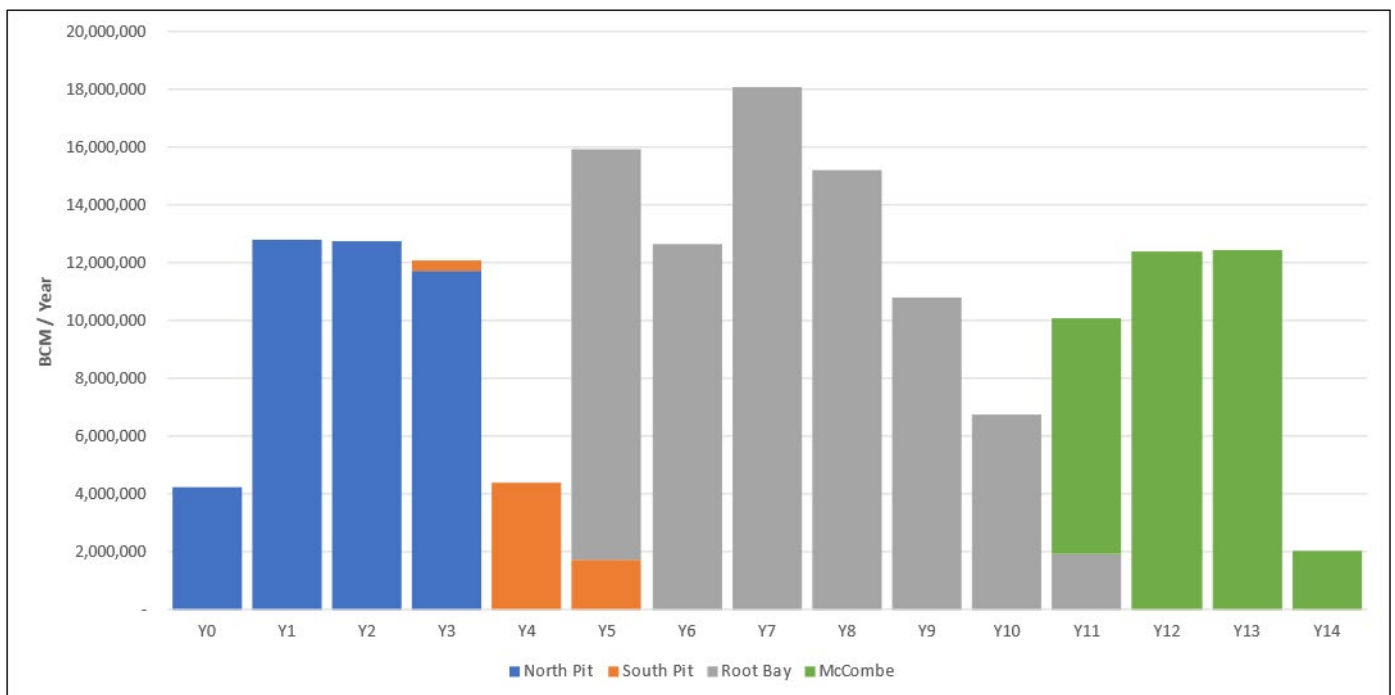

Figure 24: Long Section View of Proposed Pit Design - McCombe

Total material movement, mining sequence, fleet movement, feed material mined and ROM balance results from the schedule can be seen in Table 1-15, Figure 25 to 27 shows the key physicals by year.

**Table 1-1311 - Mining Schedule**

Year	Y0	Y1	Y2	Y3	Y4	Y5	Y6	Y7	Y8	Y9	Y10	Y11	Y12	Y13	Y14	Total
<b>Waste Mined M BCM)</b>	4.1	12.4	12.0	11.4	4.0	15.4	12.2	17.4	14.6	10.0	6.3	9.7	11.9	11.9	1.9	155.1
<b>Ore Mined (M BCM)</b>	0.1	0.4	0.7	0.7	0.4	0.5	0.4	0.7	0.6	0.8	0.5	0.4	0.5	0.5	0.1	7.4
<b>Li2O Mined Grade (%)</b>	1.5	1.1	1.0	1.4	0.5	0.9	1.2	1.3	1.2	1.3	0.9	1.0	1.0	0.9	0.9	1.1
<b>Tonnes Processed (Mt)</b>	0.0	1.0	1.5	1.5	1.5	1.5	1.8	1.5	1.5	1.5	1.5	1.5	1.5	1.5	1.1	20.4
<b>Processed Li2O Grade (%)</b>	0.0	1.2	1.0	1.1	1.4	0.6	1.1	1.3	1.2	1.3	1.2	1.0	1.0	1.0	0.9	1.1



**Figure 25: Mined Volume by Mining Area (Total)**

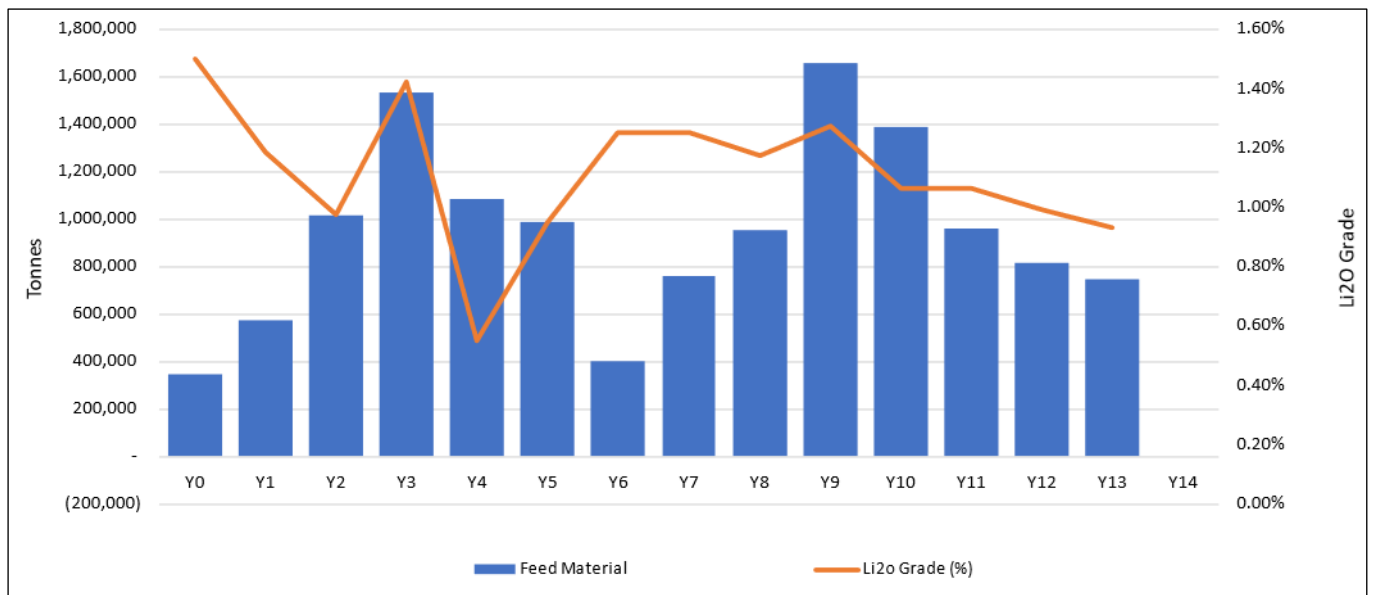

Figure 26: End of Year ROM Stockpile Tonnes and Li<sub>2</sub>O Grade Balance

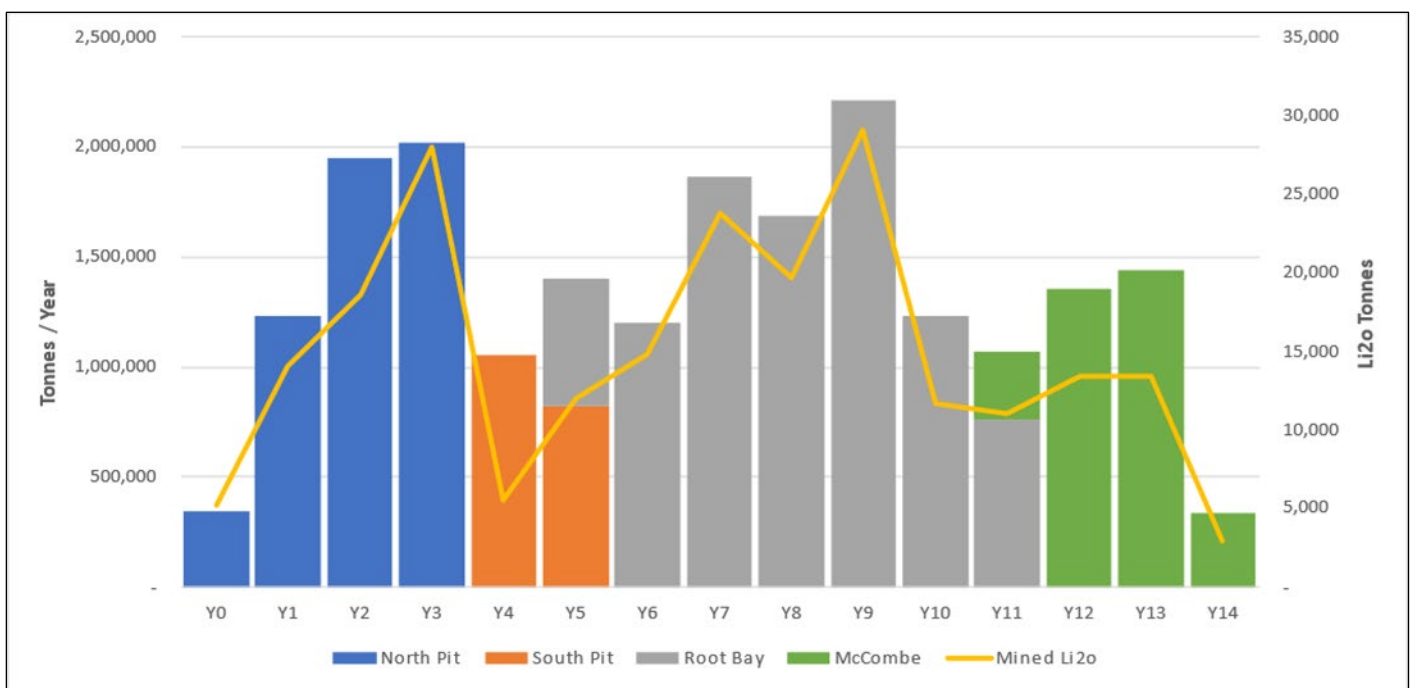

Figure 27: Mined Feed Material Tonnes and Li<sub>2</sub>O Tonnes by Mining Area

### 1.11.3.7 Production Target

The PEA production target is summarized in Table 1-14 .

**Table 1-14 12 2023 PEA Production Target (Entech, 2023)**

Classification	Tonnes (Mt)	Li <sub>2</sub> O %
Indicated	14	1.2
Inferred	6	0.8
<b>Grand Total</b>	<b>20</b>	<b>1.1</b>

Estimates have been rounded to the nearest 100,000 t of feed material. All tonnages and grades have been rounded to reflect the relative uncertainty of the estimate, thus sum of columns may not equal.

## 1.12 Processing and Recovery Methods

The Concentrators are designed to produce saleable spodumene concentrate via the use of well-known and utilized flow sheets. The two main techniques studied are specific gravity concentration using dense media separation (DMS) and standard grinding & flotation to liberate and concentrate spodumene.

Both Concentrators are designed to nominally process 1,500,000 metric tonnes per annum (tpa). The plant feeds are based on the mine block model with 10% dilution. It is important to note that the feed grade considers only the lithia found in recoverable pegmatite.

### 1.12.1 Stage 1 Seymour

The Concentrator at the Seymour property (Stage 1) will be designed and constructed as a DMS only processing facility due to the nature of the ore body, lower capex and opex and environmental considerations. For the purpose of this study the capex has been built up from supplying pre-fabricated crushing and DMS modules transported to site and assembled in position to reduce on-site costs and timeframes. Transport studies into site have been completed for various module sizes with confirmatory access.

The key process areas of the Seymour concentrator are listed as the following:

- Crushing circuit
- Feed sizing and DMS preparation
- Coarse dense media separation (DMS)
- Fine dense media separation (DMS)
- Tailings, Fines Bypass and Middlings Management

Figure 26 is a simplified process flow sheet which summarises the process flow routings within the major circuits the Seymour Concentrators.

During Stage 1 of the Project, the spodumene concentrate produced from Seymour will be transported and loaded onto trucks and ships for the purpose of selling a spodumene concentrate directly into the raw materials market until the Stage 2 Lithium Conversion Facility is completed to receive the concentrates for further processing and produce battery and technical grade lithium hydroxide monohydrate.



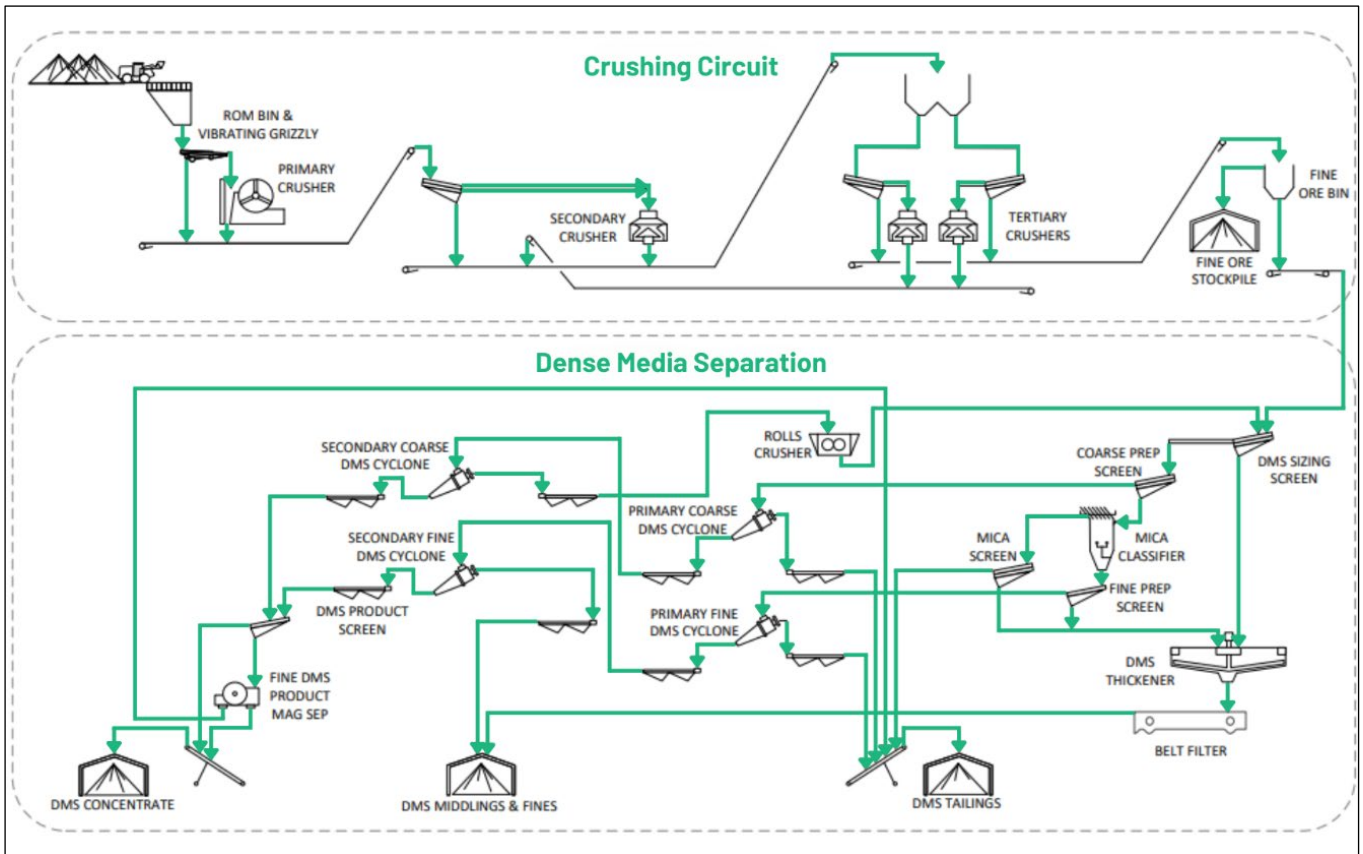

Figure 28: Seymour Project (Stage 1) Simplified Concentrator Flow Sheet

### 1.12.2 Stage 2 Lithium Hydroxide Conversion Plant Description

The Conversion facility has been studied to utilize an Alkali-leach flow sheet for the conversion of the spodumene ( $\text{LiAl}(\text{SiO}_3)_2$ ) concentrate at a targeted 5.5% grade. This process aims to transform it into a lithium carbonate form and then into a soluble lithium hydroxide, allowing crystallization to the final lithium hydroxide monohydrate product ( $\text{LiOH}\cdot\text{H}_2\text{O}$ ). This product is intended for supply to midstream Cathode Active Material (CAM) developers for further use in electric vehicle battery cell manufacturing. This process is analogous to the 'Quebec Process' which utilizes  $\text{CO}_2$  pressure leaching supplementing carbonate addition to the autoclave. The solutions generated within the circuit are recirculated as much as possible to maintain lithium concentrations, recover as much lithium as possible, and reduce water requirements.

The key process areas for the lithium conversion plant are listed as the following:

- Spodumene Concentrate Storage and Transfer
- Calcination, Grinding and Pulping
- Carbonate Leaching (Autoclave) and Filtration
- Conversion (Carbonate to Hydroxide)
- Impurity Removal
- Lithium Hydroxide Crystallization and Product Drying
- Product Handling
- Analcime/Residue Disposal

A high-level process flowsheet for the lithium hydroxide conversion plant is provided in Figure 29.

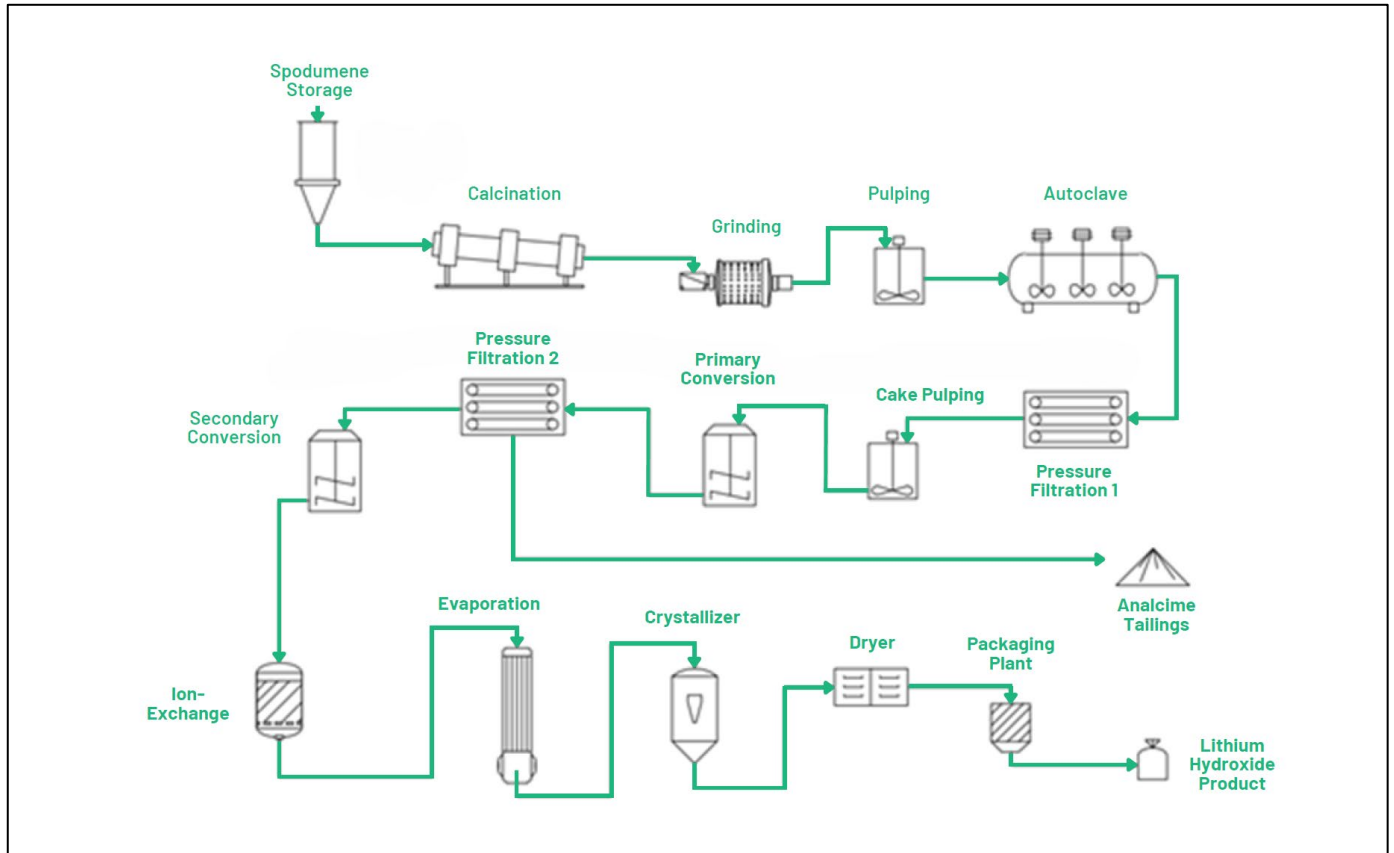

**Figure 29: Simplified Lithium Hydroxide Conversion Plant Flowsheet (Carbonation Leach)**

The Conversion facility is designed to nominally process 180,000 metric tonnes per annum of spodumene feed from the various concentrators. The design criteria used for this report are based on Primero’s experience with this flow sheet and recoveries to date. Capex, Opex and overall processing process parameters have been estimated from other reference projects that are under development.

### 1.12.3 Stage 3 Root

The Concentrator at the Root property (Stage 3) will be a hybrid combination DMS and grinding/flotation processing facility. The facility has been priced for the purpose of this study as modularized crushing and DMS circuits, similar to Seymour, with the remainder of the flowsheet developed as a ‘stick build’ scenario on site due to the scale and size of components/equipment not being suitable for modular supply.

The key process areas of the Root Bay concentrator are listed as the following:

- Crushing circuit
- Dense media separation (DMS) circuit
- Spodumene DMS concentrate magnetic separation, dewatering, and handling
- Grinding, desliming and fine magnetic separation
- Mica flotation
- Spodumene flotation
- Spodumene flotation concentrate dewatering and handling

- Fine tailings dewatering and handling
- Dry tailings dewatering and handling.

Figure 30 is a simplified process flow sheet which summarizes the process flow routings within the major circuits the Root Concentrator.

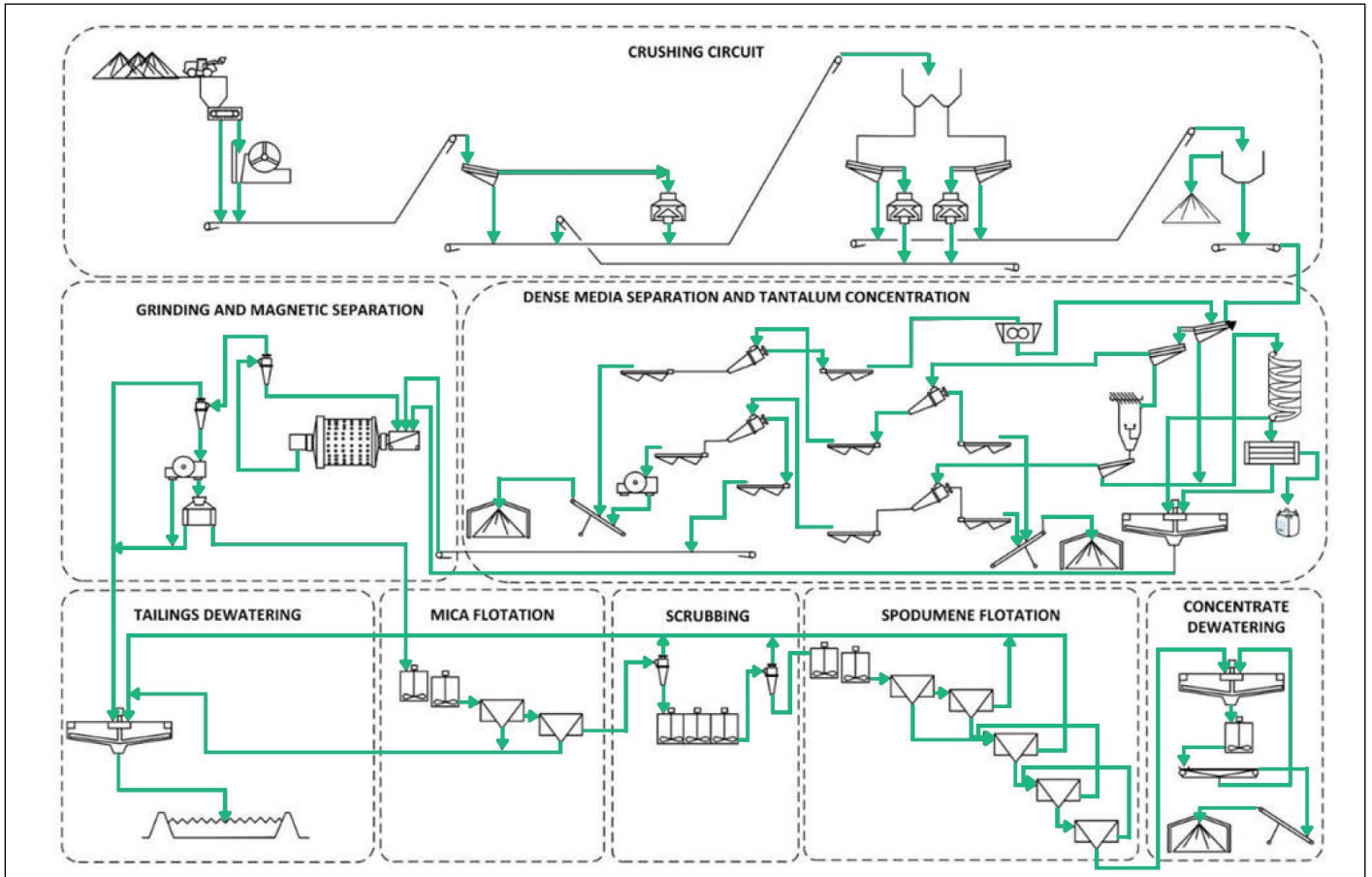

Figure 30: Root Project (Stage 3) Simplified Concentrator Flow Sheet

### 1.13 Infrastructure

#### 1.13.1 Stage 1 Seymour

The Seymour project comprises of two open pits: North Aubry and South Aubry. Waste rock will be placed into one Mine Rock Storage Area (MRSA) located to the northwest of the site. Tailings from the process plant will be placed into the DMS tailings storage facility, and the combined DMS middlings and fines storage facility. The processing plant has been located central to the pits and tailings storage facilities. In order not to discharge water into the river and lake system adjacent to the site, all surface water will be captured for the Seymour Project LOM. In year 1 and 2, contact surface water will be handled by the North Pond, in years 3 – 6 it will be conveyed into the South Pond.

The Seymour Mine is comprised of the following infrastructure, illustrated on Figure 31:

- Plant pad accommodating the processing plant, the offices, workshops, and other auxiliary infrastructure.
- Construction and operations camp adjacent to the existing exploration camp.
- MRSA.

## Preliminary Economic Assessment

- Two Water Management Ponds (North and South) to accommodate the needs of the processing plant and store the contact water onsite.
- Runoff and seepage collection system to separate the contact and non-contact water, and to convey the contact water into the Water Management Ponds.
- A DMS tailings dry stacked storage facility.
- A DMS middling and fines dry stacked storage facility.
- Overburden piles to store the topsoil and overburden for subsequent reclamation.
- An access road to connect the existing roads to the plant.
- Haul roads to connect the open pits with the plant and the MRSA.
- Temporary construction roads to facilitate the construction of the two Water Management Pond embankments.

Power generation will be built on site for the project utilizing natural gas fired containerized gensets. Compressed Natural Gas (CNG) will be trucked to site and stored/decanted as required. The Power Station will be located adjacent to the process plant.

Mine designs, site plans and overall processing layouts have been completed for the Seymour Property including mining operations, concentrate operations, overburden and MRSA, management for zero discharge to the environment and ancillary facilities have been developed for the PEA. These designs have been developed to coincide with provincial permitting requirements, First Nations considerations and best practices in the conservation and responsible development of mines under the Ministry of Mines - Ontario guidelines and requirements.

Preliminary design models have been completed for the Concentrator and Mine Services at the Seymour Property (refer Figure 21.)

Figure 32 – 32 have been completed for the next project phases with a significant amount of work already completed, that are further progressed than a standard scoping level PEA.

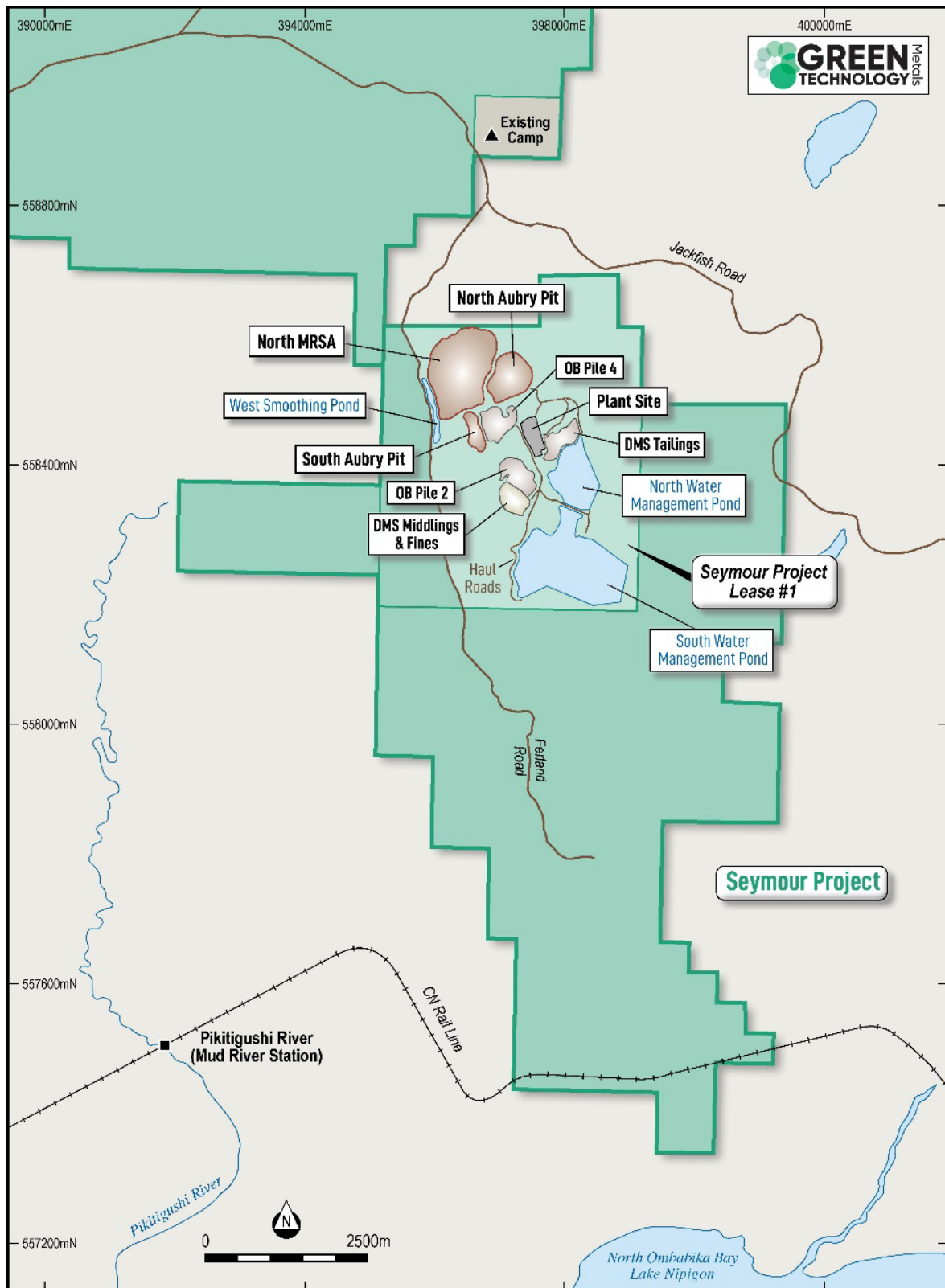

Figure 31: Seymour Project Proposed Infrastructure

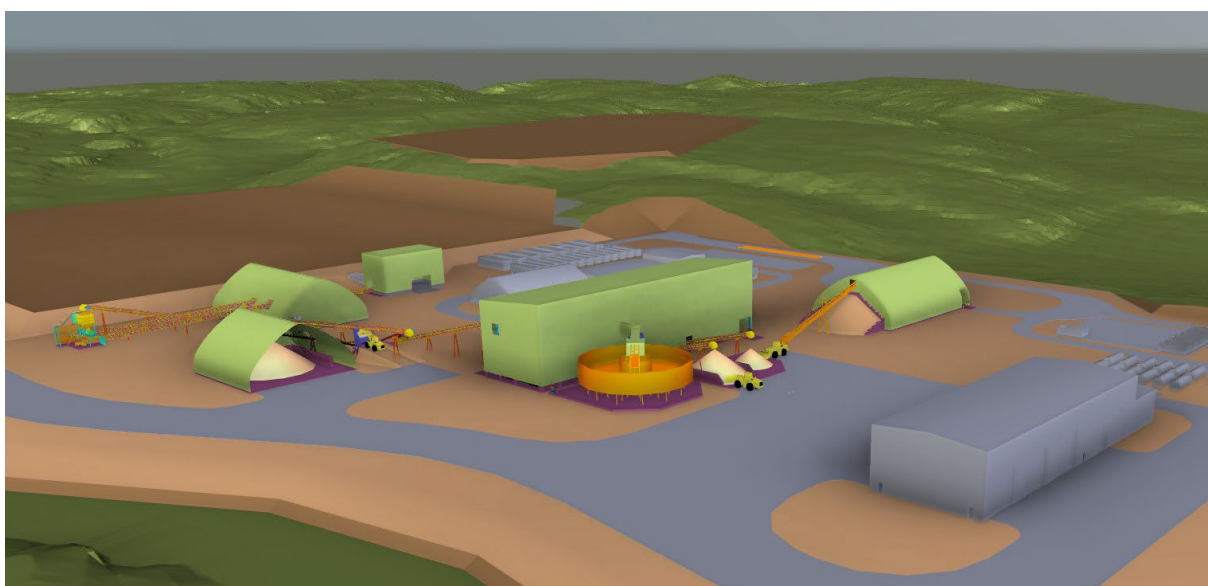

Figure 32: Seymour Concentrator & Mine Services Area

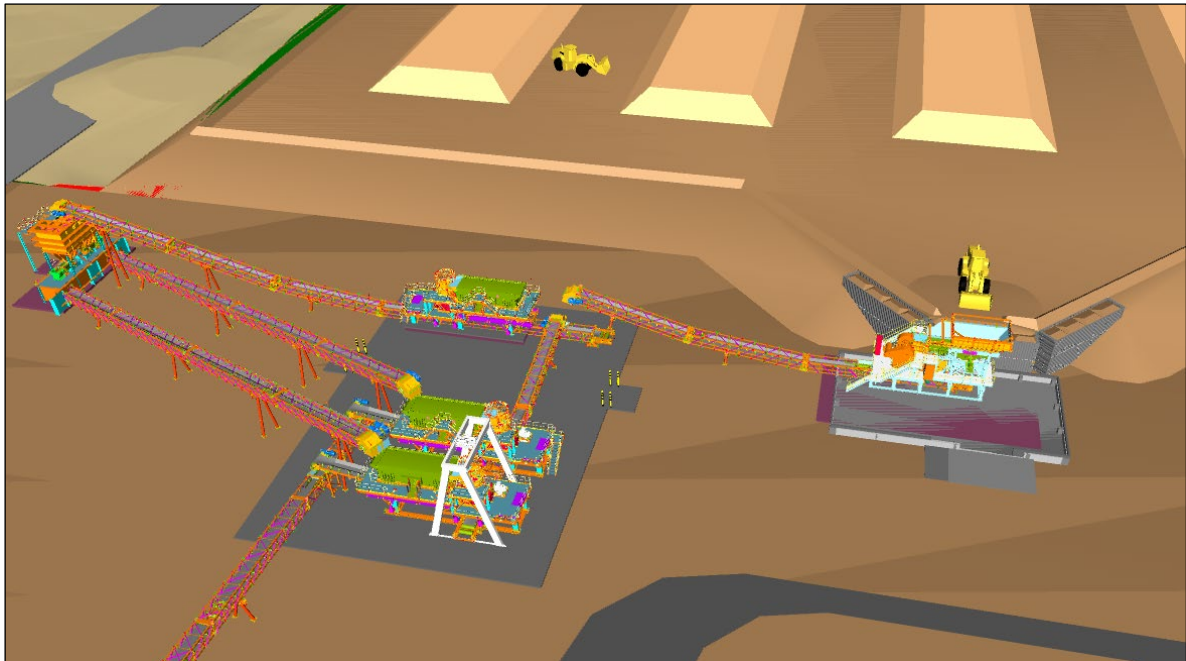

Figure 33: Seymour Crushing 3D Snapshot (Cladding Removed)

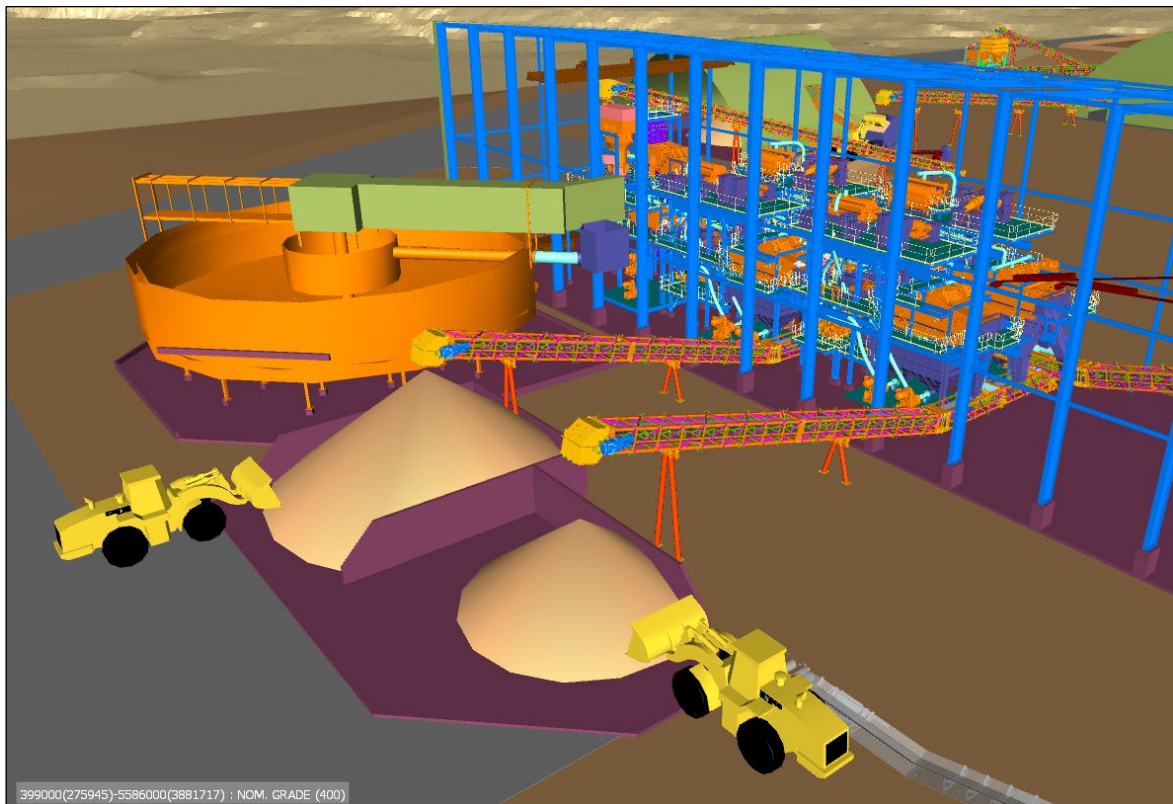

Figure 34: DMS 3D Snapshot (Cladding Removed)

### 1.13.2 Stage 2 Conversion Facility

Thunder Bay is a city of approximately 120,000 people that has an existing industrialised supply chain and labour force skillset suited to the development and operation of a Lithium Chemical facility. The city has Lakehead University and various other technical institutions streams that can provide qualified development paths for potential employees in the region, as well as specific training programs for long term sustainability.

The city will provide vital infrastructure for the construction and operational phases of the facility in the development of an industry that could transform the region over the coming years as battery minerals supply chain hub.

The site selected for this study is located on the northern side of the Thunder Bay municipal with direct access via major roads for concentrate transport from the two mine site locations to enable supply into the facility site. The access roads do not traverse through residential or sensitive traffic areas and the site is located only 4 km's from the major highway that services the sites.

The site is an existing industrial zoned site that was previously a paper and pulp mill that has been partially rehabilitated. The site will require rubble removal of the Cascade paper mill foundations and continued support and monitoring for the rehabilitated wetlands located at the far north of the block in association with Lakehead University environmental program. Several desktop studies have been completed for air/noise emissions, locality to water intake zones, and existing services to the site and these assessments are ongoing that will feed into the next phase of development study for the site as well as the permitting process.

The proposed facility has the capacity as shown in the layout below to locate two trains of conversion 20,000 to 25,000 tpa capacity each (40,000 to 50,000 tpa in total) along with dual capacity for spodumene storage, calcination, reagent storage and hydromet processing buildings. The site has existing utility services already provided/run into the site from the previous operation that have been assessed to be capable of supply utility services as required, with only minor capital upgrades required. These utilities include:

- Grid connected power – 115kV line connected to the Ontario Grid that has generation supply as 98% 'green energy' being majority Hydro Power from the numerous surrounding plants
- Natural Gas – capacity available for calcination and other service requirements
- Municipal water – potable water for any additional water make-up requirements into the processing water balance
- Municipal sewer and waste discharge – suitable for connection of domestic and moderate industrial waste streams assessed as being able to be handled by the existing city treatment regimes.



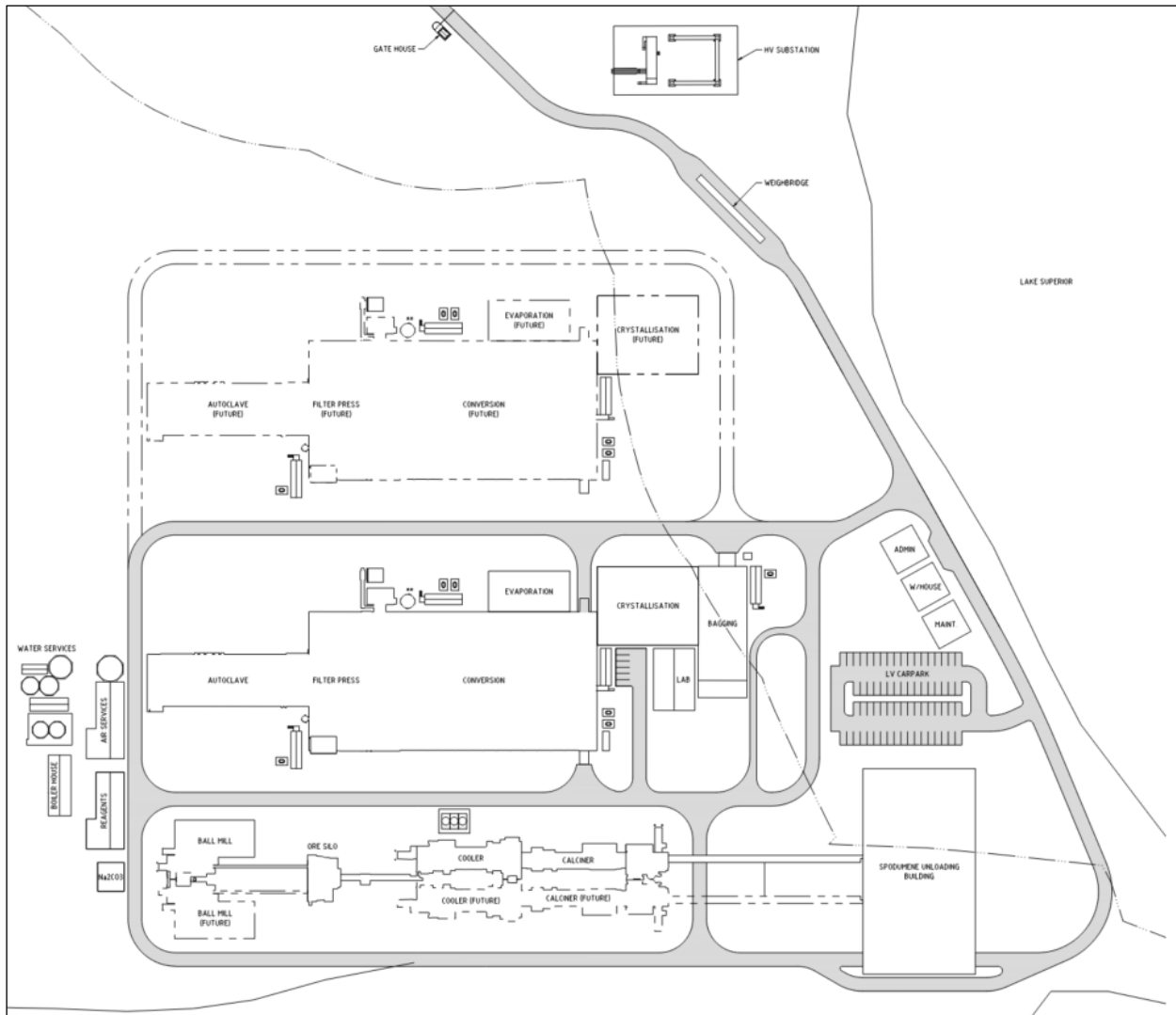

Figure 35: Lithium Hydroxide Conversion Plant Layout

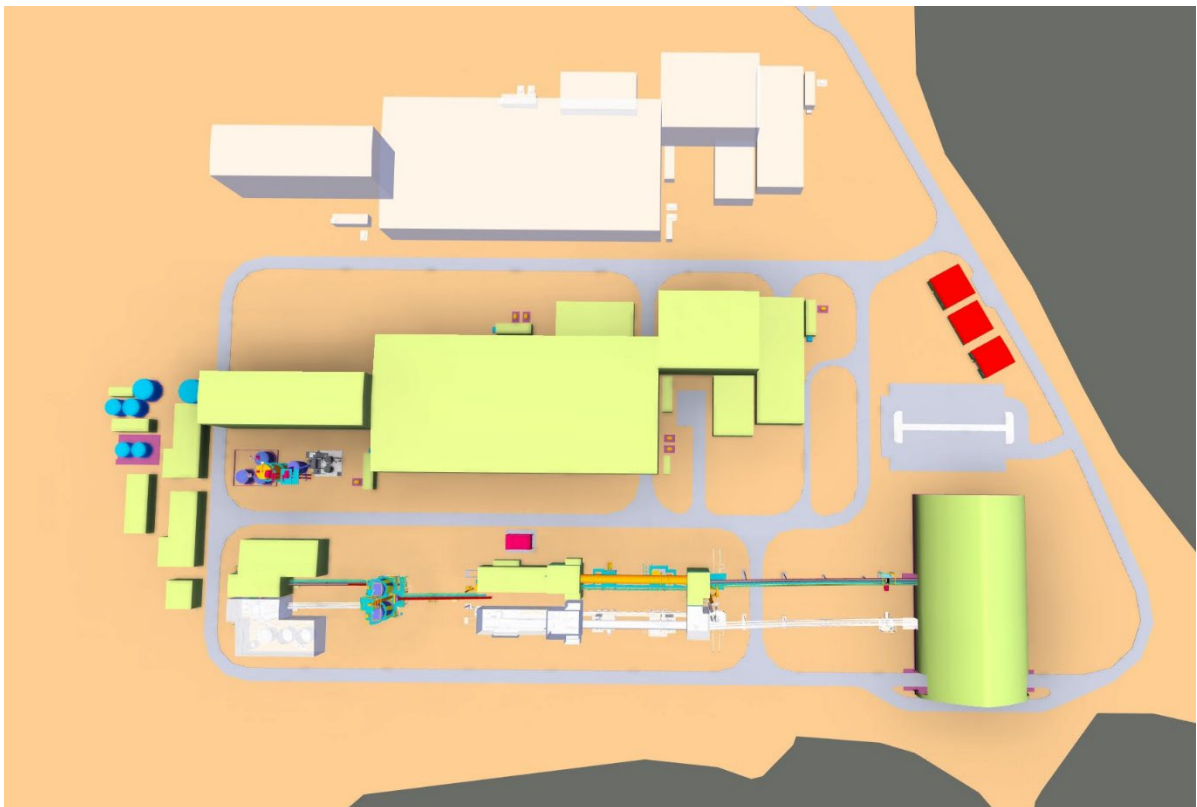
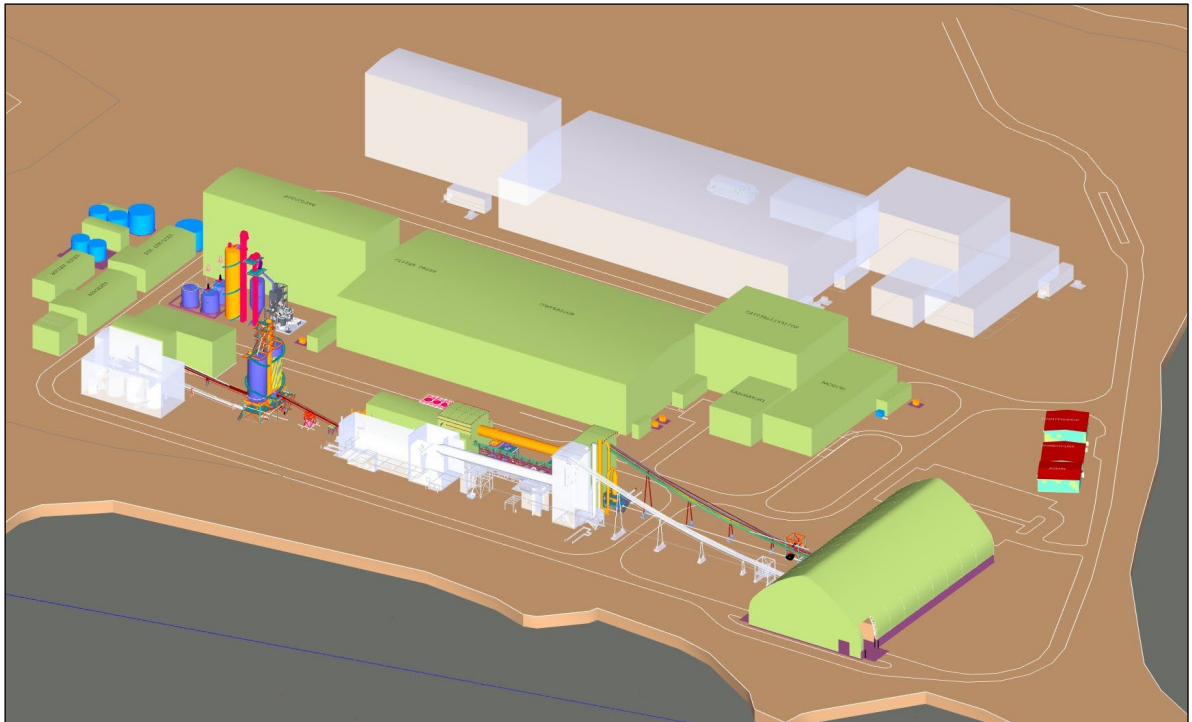

Figure 36: 3D model of the Lithium Hydroxide Conversion Plant



*Figure 37: Lithium Hydroxide Conversion Plant – Site Location*

## 1.13.3 Stage 3 Root

The Root project comprises of two distinct but closely situated open pits: Root Bay and McCombe. The Root Bay Pit is the larger of the two and the processing plant will be constructed adjacent to it. Tailings from the process plant will be placed in the Tailings Storage Facility (TSF) using the conventional aqueous slurry deposition method. The ore from McCombe Pit will be hauled to the processing plant using a 9.5 km long haul road. Waste rock will be placed into two Mine Rock Storage Areas (MRSA) at Root and one MRSA at McCombe. The surface water will be managed with the Water Management Ponds - one each in the close vicinity to both mines. Figure 38 presents the proposed layout.

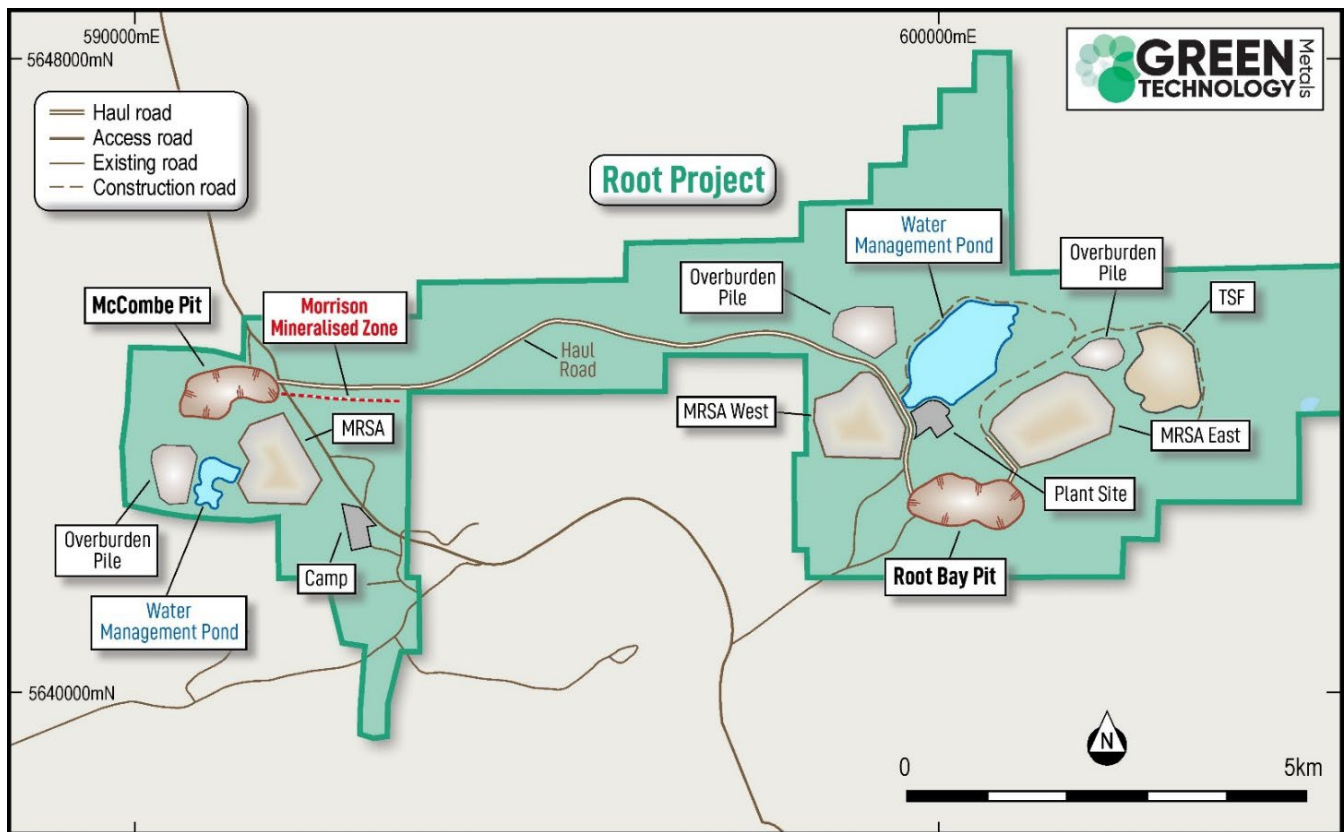

Figure 38: Root layout

The Root Bay Mine is comprised of the following infrastructure:

- Plant pad accommodating the processing plant, the offices, workshops, and other auxiliary infrastructure.
- Construction and operations camp adjacent to the existing exploration camp.
- MRSA East and MRSA West.
- A water management pond to accommodate the needs of the processing plant and manage the contact water onsite with water treatment plant to treat surplus water for discharge.
- Runoff and seepage collection system to separate the contact and non-contact water, and to convey the contact water into the water management pond.
- A Tailings storage facility.
- Overburden piles to store the topsoil and overburden for subsequent reclamation.
- An access road to connect the existing roads to the mine.
- Haul roads to connect the mine with the plant and the MRSA East and West.
- Sewage treatment

## Preliminary Economic Assessment

- Explosives magazine
- Temporary construction roads to facilitate the construction of the water management pond embankment and the TSF embankment.

The McCombe Mine is comprised of the following infrastructure:

- McCombe Pit.
- A MRSA.
- A Water Management Pond.
- A runoff and seepage collection system to separate the contact and non-contact water, and to convey the contact water into the water management pond.
- A diversion channel and two coffer dams to rout Roadhouse River around McCombe pit
- Three overburden piles.
- An access road to connect the existing roads to the mine.
- Haul roads to connect the mine with the MRSA and Root Bay plant.
- Temporary construction road to facilitate the construction of the Water Management Pond embankment.

The overall design has not been optimised at this level of study due to the staged development timing and will be further optimised at the proposed PFS level of definition planned for the next phase of development.

Preliminary design models have been completed for the Concentrator and Mine Services at the Root Property (refer Figure 39 and 40).

Root has access to the Wataynikaneyap 230kV hydro powered transmission line within 8 km of the proposed concentrator site that will supply the mine site. Initial studies and capex have been applied to provide step-down transformer compounds and reticulate power to the concentrator site.

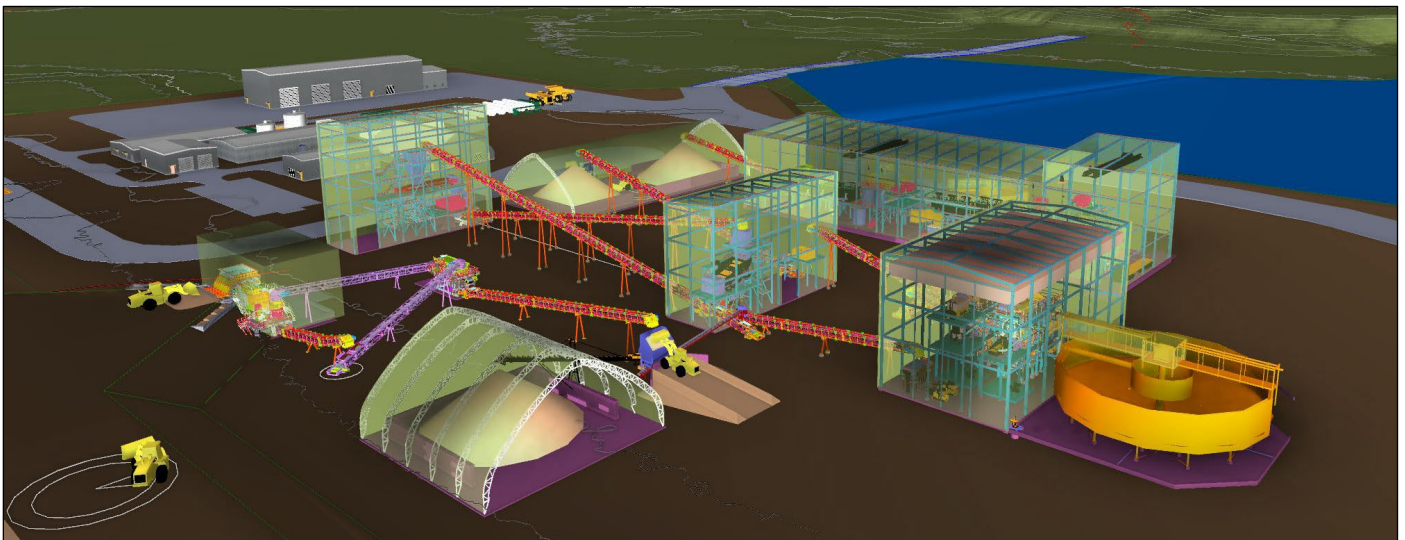

Figure 39: Root Concentrator



Figure 40: Root Grinding and Flotation

## 1.14 Market Analysis

GT1 has utilised the services of Fastmarkets, a leading independent lithium industry consultancy expert to provide a basis for the long-term lithium price forecasts for the PEA. Fastmarkets is a cross-commodity price reporting agency (PRA) in the metals and mining, new generation energy, agriculture, and forest products markets. The nature of the Fastmarkets industry predictions and market analysis is volatile in the current market situation given the expanding Lithium supply chain. Due to the difference between the two reports utilised and benchmarked for this economic assessment, GT1 has used a blended forward looking price for both lithium concentrates and chemicals as assumptions are consistently changing in the industry.

### 1.14.1 Lithium Supply and Demand

Fastmarkets expects the market to be mainly in deficit until 2026 due to strong demand for lithium-ion batteries in both EVs and increasingly Energy Storage Systems. Although total supply growth is expected to outpace LCE demand between 2022 and 2025 (121% vs 104%), manufacturing losses as new plants ramp up and the need to build working stock to feed them will likely keep the market in deficit, even with the supply chain running off less-than-ideal inventory levels.

A period of the surplus is likely in the second half of the decade as a continuous stream of projects incentivised by the current price regime and backed by government policy support, begin to come online. These surpluses are not a bad thing, with potentially five years of preceding deficits, it represents an opportunity for restocking. Additionally, experience suggests that project delays and other issues are likely to affect the delivery of new material into the market, limiting surpluses back toward a balanced market.

A lack of visibility on supply toward the tail end of the period results in the development of large deficits. In reality, this is unlikely to come to fruition. Our expectations, displayed in our price forecast is for a continued high price, that will incentivise project development and ensure that supply will come online to fill these gaps.

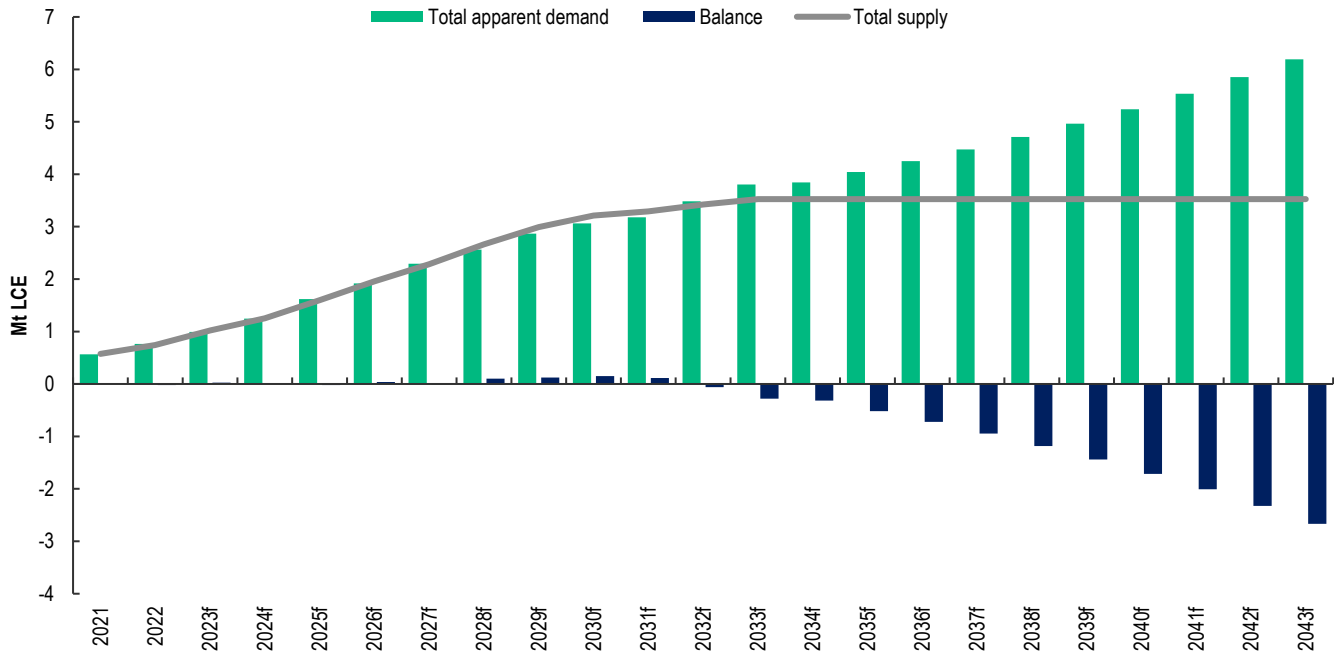

Figure 41: Lithium supply and demand balance

### 1.14.2 Lithium Pricing

Fastmarkets expects lithium prices to remain elevated above the cost curve in order to incentivise supply expansion. However, it is believed that recent peak lithium salt prices at \$70 per kg, or spodumene at \$6,600 per tonne are unsustainable and prices will settle at a level that is mutually beneficial for both producer and consumer. Price volatility however remains a theme and a return to elevated price levels are possible for short periods in times of extreme supply squeeze.

In the near term, Fastmarkets expects lithium hydroxide and carbonate prices to continue to fall despite the forecast deficit. Hydroxide and carbonate prices are expected to fall to an average of \$29 per kg and \$28 per kg in 2025 respectively, still above the long-term average and cost curve.

More ample supply is expected in the latter half of this decade, and this should continue to see prices fall. Fastmarkets forecasts lithium hydroxide and lithium carbonate prices to reach a low of \$25 per kg and \$23 per kg respectively in 2029. Spodumene (SC6) is expected to reach a low of \$2,100 per tonne.

Between 2033 and 2043 we expect the lithium hydroxide and carbonate to be at a price parity and average \$25 per kg over the period. Fastmarkets have provided a base, high, and low case price forecast below, to give an indication of the range of which prices could sit, depending on reasonable assumptions around potential impacts to the base.

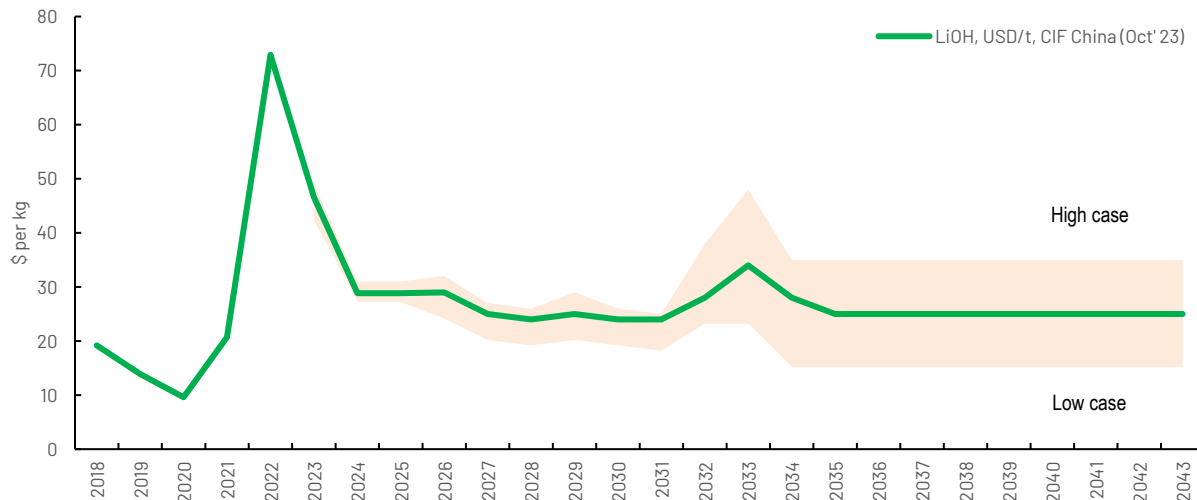

Figure 42: Fastmarkets Pricing Forecast (Lithium Hydroxide)

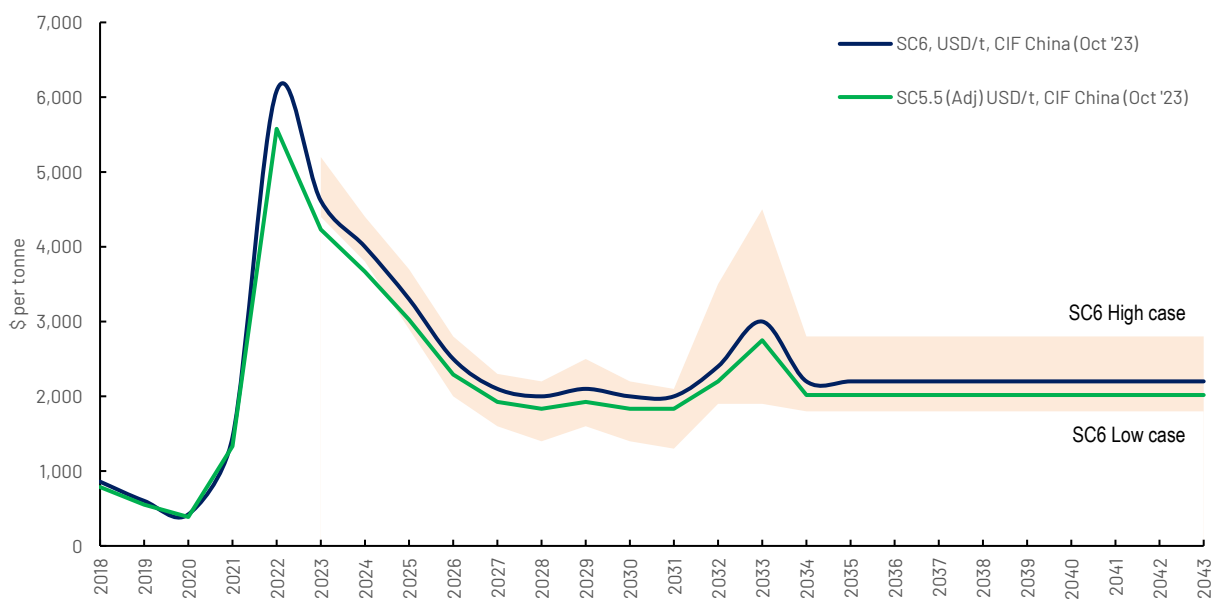

Figure 43: Fastmarkets pricing forecast Spodumene Concentrate

### 1.15 Environmental Studies and Permitting

The Projects are in a jurisdiction that has hosted mining developments for over a century and has well established regulatory processes for new project approvals. Recent initiatives from federal and provincial governments to support battery minerals are expected to further expedite the approval processes for the development of the projects.

Baseline studies for Seymour were initiated in 2018 and are on-going, whilst baseline studies at Root commenced in April 2023 due to the staged development timing. Refinements to the baseline work will continue to be made, based on input



from government agencies and the consultation process. The objectives of the baseline work are to characterize pre-development conditions, including any liabilities or legacy issues, identify any sensitive sites that need to be considered in the project planning stage and gather the information that is required to support the approvals process.

The anticipated approvals process for the project components are described herein and are summarised below. If material changes are made to any of the project components, the approval process will need to be reviewed.

- **Stage 1** - Seymour: Provincial class environmental assessment, provincial permits
- **Stage 2** - Conversion Facility: Provincial permits, municipal permits
- **Stage 3** - Root: Federal impact assessment, provincial class environmental assessment, federal and provincial permits

Anticipated environmental sensitivities associated with the projects include rock management, tailings management, water management, fugitive dust, noise and traffic. Mitigations and engineered abatement measures for these issues are well established. The on-going consultation process will allow refinements to the mitigation strategies for sensitivities such as noise and traffic.

Closure planning for the project components will follow the prescriptive requirements in the Mine Rehabilitation Code of Ontario (Mining Act, Regulation 240/00). Based on current information, the risk of acid generation and metal leaching is low as assessed at both Seymour and Root projects. Accordingly, closure planning focuses on physical stability, removing infrastructure and supporting traditional use of the land by local communities.

Engagement and consultation with Indigenous communities, under the guidance of the Crown, will continue to be prioritised across all three project sites and stages. GT1 has implemented a proactive approach to identify and resolve issues and develop the Project in a manner that respects the interests of Indigenous communities as well as local stakeholders.

### 1.15.1 Seymour Permitting and Approvals

The permitting process continues on schedule, marked by a recent significant achievement of successfully obtaining the Mining Lease for the Seymour Lithium Project from the Department of Mines for a period of 21 years. The mining lease covers the proposed mining and processing construction areas of the Project and is a prerequisite before any project development activities. The granted Mining Lease for Seymour represents a significant achievement in de-risking the Project on the path toward development and production.

Additionally, in September 2023, marking 7 months post-submission, the company obtained its Environmental Assessment category determination from the Ministry of Natural Resources and Forestry (MNR). The determination clarifies the scope and procedures for the EA process that is required to be completed before MNR can issue permits for the project and this process is targeted to be completed in Q1 2024.

The company continues to prioritise engagement with Indigenous communities and government bodies as it works towards securing the remaining permits required to commence construction at the project. GT1 has received formal consultation lists for Indigenous communities assessed by the Crown and is continuing the consultation with multiple groups as required under the various legal frameworks. Presently, the company is working with First Nations in preparation for the timber harvesting that is planned to commence in the first quarter of 2024, contingent upon obtaining the necessary approvals in line with the project schedule.

GT1 maintains a positive relationship with pertinent government agencies and are active in discussions related to pre-submission consultation with relevant government departments for the permits listed in figure 44. Notably, GT1 is currently in discussions with the Ministry of Environment, Conservation and Parks (MECP) and is awaiting a determination regarding the potential necessity for permits under the Endangered Species Act. The company look forward to providing updates in the permitting process as it advances in the coming months.

Agency	Permit / Approval	Status
Ministry of Mines	Mining Lease – Mine Site	Approved
	Mining Lease – Camp	Submitted for approval
	Mining Lease – Stage 2	Submitted for approval
	Indigenous Consultation and Accommodation	Underway
	Closure Plan	Draft currently being used to facilitate consultation process
Ministry of Natural Resources and Forestry	Class Environmental Assessment Environmental Assessment category determination – Consultation – <b>underway</b>	Received
	Construction Permits Stage 1 – Permit to remove timber ( <b>Submitted for approval</b> ) – Lake and Rivers Improvement Act approval ((location approval; plans and specifications approval)	Underway
	Construction Permits Stage 2	Underway
	Overall Benefit Permit Determination if a permit is required is in progress by the Ministry	Planning
Ministry of Environment, Conservatory and Parks	Permit to Take Water	Application submission Q1 2024
	Air Environmental Compliance Approval	Application submission Q1 2024
	Sewage Environmental Compliance Approval	Application submission Q3 2024

**Figure 44: Indicative permitting schedule for the Seymour Lithium Project**

The above timing assumptions are indicative and are subject to change.

## 1.16 Capital and Operating Costs

The objective of developing the capital and operating cost estimates is to provide costs feeding into the PEA pertaining to the GT1 Integrated strategy.

The parameters for the capital costs estimates used are as follows:

- Estimate Target Accuracy Initial Capital Costs                   +30% / -30%;
- Estimate Target Accuracy Deferred Capital Costs                   +35% / -35%;
- Estimate Target Accuracy Sustaining Capital Costs                   +30% / -30%;
- Estimate Target Accuracy Operating Costs                           +30% / -30%;
- Estimate Base Date   Q4 2023;
- Estimate Base Currency   CAD.

## 1.16.1 Stage 1 – Seymour Initial Capex

A summary of the capital cost estimate for the initial mine and concentrator plus associated infrastructure is presented in Table 1-15

*Table 1-1513 – Stage 1 Seymour Initial CAPEX Summary*

Area	Capital (CAD)
1100 - Site General	21M
1200 - Mining	1M
1300 - Processing Plant	69M
1400 - Site Infrastructure	23M
1500 - Camp	7M
1600 - Storage Facilities	24M
6100 - Seymour Concentrator Indirects	38M
8100 - Owners Cost	5M
<b>Sub-total</b>	<b>188M</b>
9210 - Contingency (15%)	28M
<b>Total inc Contingency</b>	<b>216M</b>
8214 - Mining Pre-Production	53M
8213 - Plant and Admin Pre-Production	13M
<b>Total inc Pre-Production and Contingency</b>	<b>282M</b>

Contingency is set at 15%.

## 1.16.2 Stage 2 – Conversion Initial Capex

A summary of the capital cost estimate for the inclusion of the conversion plant and associated infrastructure is presented in Table 1-16.

*Table 1-1614 – Stage 2 Conversion Facility Initial CAPEX Summary*

Area	Capital (CAD)
4200 - LiOH Plant	607M
4300 - Site Infrastructure	27M
4400 - Tailings Disposal	0.4M
6300 - Lithium Hydroxide Indirects	168M
8100 - Owners Cost	38M
<b>Sub-total</b>	<b>840M</b>
9230 - Contingency (25%)	210M
<b>Total inc Contingency</b>	<b>1,050M</b>
8233 - Plant Pre-Production	13M
<b>Total inc Pre-Production</b>	<b>1,064M</b>

Contingency is calculated at 25% and is based on the accuracy of study design and pricing.

## 1.16.3 Stage 3 –Root Initial Capex

A summary of the capital cost estimate for the inclusion of Root mine and concentrator and associated infrastructure is presented in Table 1-17. Based on the project development timeline, Root CAPEX is expended in years 2029-2030 and does not form part of the upfront capital cost.

*Table 1-1715 - Stage 3 Root Initial CAPEX Summary*

Area	Capital (CAD)
2100 - Site General	37M
2200 - Mining	1M
2300 - Processing Plant	138M
2400 - Site Infrastructure	43M
2500 - Camp	7M
2600 - Storage Facilities	25M
6200 - Root Concentrator Indirects	70M
8100 - Owners Costs	9M
<b>Sub-total</b>	<b>329M</b>
8220 - Contingency (15%)	49M
<b>Total inc Contingency</b>	<b>378M</b>
8224 - Mining Pre-Production	79M
8223 - Plant Pre-Production	10M
<b>Total inc Pre-Production and Contingency</b>	<b>467M</b>

Contingency is set at 15%

## 1.16.4 Sustaining and Closure Capex

Table 1-18 includes a summary of the capital cost estimate for the sustaining and closure CAPEX for Seymour, Conversion Facility and Root. The table includes all associated sustaining costs for mining, plant and infrastructure.

*Table 1-1816 - Sustaining and Closure Capex Summary*

Area	Capital (CAD)
Operating Year 1 North Water Management Pond	8.1M
Operating Year 2 South Water Management Pond	15.0M
Operating Year 3 South Water Management Pond	10.0M
Operating Year 4	5.2M
Operating Year 7	0.5M
Operating Year 8	5.9M
Operating Year 9	0.4M
Operating Year 10 McCombe Establishment	38.5M
Operating Year 11	1.5M
Operating Year 12	1.0M

Area	Capital (CAD)
Operating Year 13	0.4M
Seymour Closure Year 7	19.4M
Root Closure Year 14	31.1M
Converter Sustaining Capital	57M
<b>Total Sustaining</b>	<b>137M</b>

## 1.16.5 Mining Operating Costs

The mining schedule formed the basis of a mining cost estimation conducted by Entech. As part of the mining cost estimate, Entech benchmarked costs from similar mining operations within their database. Cost estimates were provided to GT1 which were integrated into their PEA project financial model. Capitalised mining costs are presented in the tables above. Operating mining costs are summarised in Table 1-19 below.

*Table 1-1917 - Total Capital and Operating Mining Costs*

Operating (LOM)	CAD\$ (M)	CAD\$/BCM	CAD\$/ t Ore feed
Drill & Blast	415	2.55	20.34
Load & Haul	1604	9.87	78.66
Dayworks	20	0.12	0.99
Grade Control	22	0.14	1.08
Overheads	66	0.40	3.22
<b>Total Operating</b>	<b>2127</b>	<b>13.08</b>	<b>104.29</b>

## 1.16.6 Stage 1 – Seymour OPEX

The average annual operating costs for the Seymour concentrator provided in General and Administration costs were provided by third party consultants.

Table 1-20. General and Administration costs were provided by third party consultants.

*Table 1-18 – Concentrator: Spodumene Processing Plant OPEX Summary – Stage 1 – Seymour Project*

Cost Center	Total Cost		
	CAD/year	CAD/t feed	CAD/t final product
<b>Concentrator Process Plant</b>			
Process Plant Power	7,831,691	5.22	40.14
Process Plant Labour	10,294,939	6.86	52.76
Process Plant Maintenance	869,785	0.58	4.46
Process Plant Consumables	1,858,101	1.24	9.52
Process Plant Reagents	1,318,960	0.88	6.76
Process Plant Mobile Equipment	804,923	0.54	4.13
Process Plant Laboratory	693,420	0.46	3.55
Process Plant Concentrate Transport	9,859,666	6.57	50.53

Cost Center	Total Cost		
	CAD/year	CAD/t feed	CAD/t final product
Process Plant Natural Gas Heating	1,012,389	0.67	5.19
Process Plant General and Administration	815,850	0.54	4.18
<b>Concentrator Process Plant Total</b>	<b>35,359,724</b>	<b>23.57</b>	<b>181.22</b>
<b>General and Administration</b>			
Site General and Administration	3,102,000	2.07	15.90
Site G&A Labour	4,256,179	2.84	21.81
Site Power	2,805,453	1.87	14.38
Camp	4,605,767	3.07	23.60
Site Sewage Treatment	36,000	0.02	0.18
Site Water Treatment	500,000	0.33	2.56
<b>General &amp; Administration Total</b>	<b>15,305,399</b>	<b>10.20</b>	<b>78.44</b>
<b>Total OPEX</b>	<b>50,665,124</b>	<b>33.78</b>	<b>259.65</b>

Concentrate transport costs vary on a year-by-year basis depending on concentrator production rates and conversion plant demands. Water treatment costs, which are included in General & Administration – Other, vary from Year 3 onwards. These variations are covered within the financial model, refer to Section 1.17.

### 1.16.7 Stage 2 – Conversion Facility OPEX

The average annual operating costs for the Thunder Bay Conversion Facility provided in Table 1-21.

*Table 1-2119 – Conversion Facility OPEX Summary*

Cost Center	Total Cost		
	CAD/year	CAD/t feed	CAD/t final product
Workforce (Process Labour)	20,268,766	112.60	828.30
Operating Spares and Consumables	76,572,423	425.40	3,129.21
Power Cost	10,825,199	60.14	442.38
Plant Maintenance Supplies	20,702,381	115.01	846.02
Mobile Equipment	1,022,700	5.68	41.79
Laboratory	3,034,720	16.86	124.02
General & Administration - Labour	2,719,286	15.11	111.13
General & Administration - Other	2,420,249	13.45	98.91
<b>Total</b>	<b>137,565,725</b>	<b>764.25</b>	<b>5,621.76</b>

### 1.16.8 Stage 3 – Root OPEX

The average annual operating costs for the Root concentrator provided in Table 1-22.

**Table 1-202 – Spodumene Processing Plant OPEX Summary – Stage 3 – Root Bay and McCombe Project**

Cost Center	Total Cost		
	CAD/year	CAD/t feed	CAD/t final product
Concentrator Process Plant			
Process Plant Power	4,417,201	2.94	22.76
Process Plant Labour	11,499,634	7.67	59.26
Process Plant Maintenance	1,616,887	1.08	8.33
Process Plant Consumables	4,040,383	2.69	20.82
Process Plant Reagents	8,792,636	5.86	45.31
Process Plant Mobile Equipment	804,923	0.54	4.15
Process Plant Laboratory	1,265,993	0.84	6.52
Process Plant Concentrate Transport	7,088,793	4.73	36.53
Process Plant Natural Gas Heating	1,010,692	0.67	5.21
Process Plant General and Administration	917,350	0.61	4.73
<b>Concentrator Process Plant Total</b>	<b>41,454,492</b>	<b>27.64</b>	<b>213.62</b>
<b>General and Administration</b>			
Site General and Administration	3,167,000	2.11	16.32
Site G&A Labour	4,295,928	2.86	22.14
Site Power	783,792	0.52	4.04
Camp	7,007,410	4.67	36.11
Sewage Treatment	36,000	0.02	0.19
Process Plant Water Treatment	1,000,000	0.67	5.15
<b>General &amp; Administration Total</b>	<b>16,290,130</b>	<b>10.86</b>	<b>83.95</b>
<b>Total OPEX</b>	<b>57,744,621</b>	<b>38.50</b>	<b>297.57</b>

Concentrate transport costs vary on a year-by-year basis depending on concentrator production rates and conversion plant demands. Water treatment costs, which are included in General & Administration – Other, vary from Year 3 onwards. These variations are covered within the financial model, refer to Section 1.17.

## 1.17 Economic Model and Sensitivity Analysis

A detailed financial model and discounted quarterly cash flow (DCF) has been developed to complete the economic assessment of the project and is based on current (Q4 2023) price projections and cost estimates in Canadian dollars (CAD). All financials have been converted into CAD using a USD/CAD rate of 0.75. No price escalation has been included to account for the effects of future inflation, but cost estimates incorporate recent inflationary price increases. The evaluation was carried out on a 100%-equity and 100% project ownership basis using an 8% discount factor. Current Canadian federal and Ontario provincial tax regulations were applied to assess the corporate tax liabilities.

There are two scenarios modelled in the DCF:

- Mining and Concentrators – This scenario evaluates the economics of Spodumene production from both the Seymour Project and The Root Project over their respective mine lives, without the Converter. It includes all capital and operating costs for mining and concentrator operations and based on selling SC5.5 to external parties.

## Preliminary Economic Assessment

- Integrated Project – evaluates the economics of the Integrated project that includes the mines, concentrators and Lithium Hydroxide facility, over a 15-year mine life. This option confined to the current Mineral Resource Estimates for both the Seymour and Root projects that the company foresees significant expansion through ongoing exploration efforts in the upcoming years.
- The financial outcomes of these two scenarios is demonstrated Table 1-23 and Table 1-24 below.
- GT1 is optimistic that the conversion facility in the integrated project scenario has the potential to operate for an additional 10 years beyond the current scope of this PEA and that an extension to LOM will yield an improved NPV for the integrated project. This extended operational period would surpass the current resource estimates and potentially incorporate additional supply of SC5.5 feed from North American-based suppliers which GT1 remains actively engaged in discussions for this strategy.
- Additionally this strategy is supported by local and provincial government bodies, along with strategic partners including the Thunder Bay Community Economic Development Commission (CEDC) who are actively committed to fostering economic opportunities for the city. This includes providing support for various lithium resource projects in the region and the establishment of a lithium hydroxide facility within the city. GT1 envisions that this development scenario will result in a surplus of feed from both new and existing mineral resources in the region surrounding the Converter, making it available as a feedstock over the remaining 10-year period.

**Table 1-2321 – Project Returns**

Base Case Financial Results	Unit of Measure	Mining and Concentrators	Integrated Project
Project Length	Y	15	15
After-Tax NPV @ 8%	\$ CADM	1,189	1,506
After-Tax IRR	%	53.9	27.4
After-Tax Payback Period	Y	1.25	3.25

**Table 1-2422 – Profit & Loss Summary**

Income Statement	Mining and Concentrators	Integrated Project
	CAD million	CAD million
Gross revenues (SC5.5 and LiOH)	7,958	14,230
Royalties and Transportation	(858)	(434)
<b>Net revenues</b>	<b>7,100</b>	<b>13,796</b>
Raw Materials		(2208)
Operational Expenditure	(2,770)	(4,300)
<b>EBITDA</b>	<b>4,331</b>	<b>7,288</b>
Capital expenditure (pre-production)	(749)	(1,812)
Sustaining and deferred capital	(137)	(154)
Gross profit before tax (EBT)	3,445	<b>5,322</b>
Tax	(896)	(1,384)
<b>Net Profit After Tax (NPAT)</b>	<b>2,549</b>	<b>3,938</b>

### 1.17.1 Financial assumptions

The major financial assumptions, not detailed within this report, that have been utilised in the two scenarios are listed in Table 1-26 Commodity forecasts are based on a Fastmarkets long term pricing study of 6.0% Li<sub>2</sub>O Spodumene Concentrate product and Battery Grade Lithium Hydroxide product undertaken in Q4 2023 (table 1-25). The price used for SC5.5 was based on a pro rata of the SC6 price on Lithium volume. Hydroxide prices are assumed to be FOB from Thunder Bay. Details



on the derivation of this price forecast are given in Table 1-25. The sensitivity analysis examines the high and low range that were identified in the Fastmarkets study.

**Table 1-25 23- Yearly Price Assumptions**

FastMarkets Price Forecast	2026	2027	2028	2029	2030	2031	2032	2033	2034	2035 onwards
LiOH (USD/tonne)	29,000	25,000	24,000	25,000	24,000	24,000	28,000	34,000	28,000	25,000
SC6 (USD/tonne)	2,500	2,100	2,000	2,100	2,000	2,000	2,400	3,000	2,200	2,200
SC5.5 (USD/tonne)	<b>2,292</b>	<b>1,925</b>	<b>1,833</b>	<b>1,925</b>	<b>1,833</b>	<b>1,833</b>	<b>2,200</b>	<b>2,750</b>	<b>2,017</b>	<b>2,017</b>

The base case was carried out on a 100 % equity basis. A discount factor of 8% was chosen as a reflection of the average cost of capital and for comparative project analysis.

**Table 1-2624 - Financial Assumptions**

Item	Source	Unit of Measure	Value
Lithium Hydroxide Sale Price (Variable)	Fastmarkets	\$USD/t	Per table above
SC5.5 Price (Variable) - External	Fastmarkets	\$USD/t	Per table above
SC5.5 Price - Internal during current Mine Life	GT1	\$/t	976
SC5.5 Price (Variable) - Assumed SC5.5 to be sourced at this rate post current mine life	GT1	\$/t	976
Seymour Li <sub>2</sub> O Recovery	GT1	%	65
Root Li <sub>2</sub> O Recovery	GT1	%	75
LiOH Recovery	GT1	%	92
Discount Factor	-	%	8
Applicable Tax Rate	CRA	%	26
Mining Tax Rate	ONgov	%	8
Net Smelter Royalty - Seymour	GT1	%	1.5
Net Smelter Royalty - Root	GT1	%	1.5
Indigenous consultation and accommodation	GT1	%	Confidential
CAD/USD Exchange Rate	GT1	\$	0.75
Mine / Concentrator Depreciation	ONgov		7 Year Straight Line
Conversion Plant Depreciation	ONgov		7 Year Straight Line

## 1.17.2 Technical Assumptions

The main technical assumptions in the model are outlined in Table 1-27.

The total mine life in the model is 15 years (excluding a 4-month pre-strip period). The Seymour concentrator (DMS only) commences operations at the completion of the pre-strip and has a ramp up period of 6 months before it reaches nameplate production. The Root Concentrator (DMS & Flotation) comes online in year 5 and has a ramp up period of 9 months before it reaches nameplate production. Before and during the Converter operations it is assumed any SC5.5 produced that is not required by the converter is sold externally. The Converter commences 2.5 years after the concentrator operations commence with a ramp up period of 24 months before reaching nameplate production.

For modelling purposes the converter facility is assumed to have a life of 15 years, however GT1 believe the facility can operate for a further 10 years with additional feed sourced organically from continued exploration or from other regional operators within North America.

**Table 1-2725 - Project Production Summary**

<b>Production Summary</b>	<b>Value</b>	<b>Units</b>
Ore feed mined (inc prestrip)	20.4	Mt
Waste mined (inc prestrip)	451.7	Mt
Total material mined (inc prestrip)	472.1	Mt
Mine life	15	years
Average strip ratio (waste:ore)	22.15	(w:o)
LOM average annual ore production	1.46	Mtpa
LOM Average Li <sub>2</sub> O grade (undiluted)	1.13	% Li <sub>2</sub> O
Concentrator Throughput (maximum) – Seymour	1.5	Mt
Concentrator Throughput (maximum) – Root	1.5	Mt
Concentrator Ramp Up – Seymour	6	mths
Concentrator Ramp Up – Root	9	mths
Spodumene Concentrate Produced	2.93	Mmt (dry)
Spodumene Concentrate Grade	5.5	%
Average Li <sub>2</sub> O recovery	71.6	%
LiOH Converter Throughput (maximum)	180	kt
LiOH Converter Ramp Up	24	mths
LiOH:H <sub>2</sub> O Recovery	92	%
Average annual (LiOH) Production	24.4	kt

An allowance of 43.63 CAD / tonne of feed has been made for tailings disposal in the financial model. Tantalum revenue has also not been considered at this stage pending further test programs.

### 1.17.3 Sensitivity Analysis

GT1 has studied the economical models’ sensitivity regarding a variation of parameters:

- Capital cost
- Operating cost
- Recovery
- Product pricing
- Throughput

The results are summarized in Figures 45 & 46.

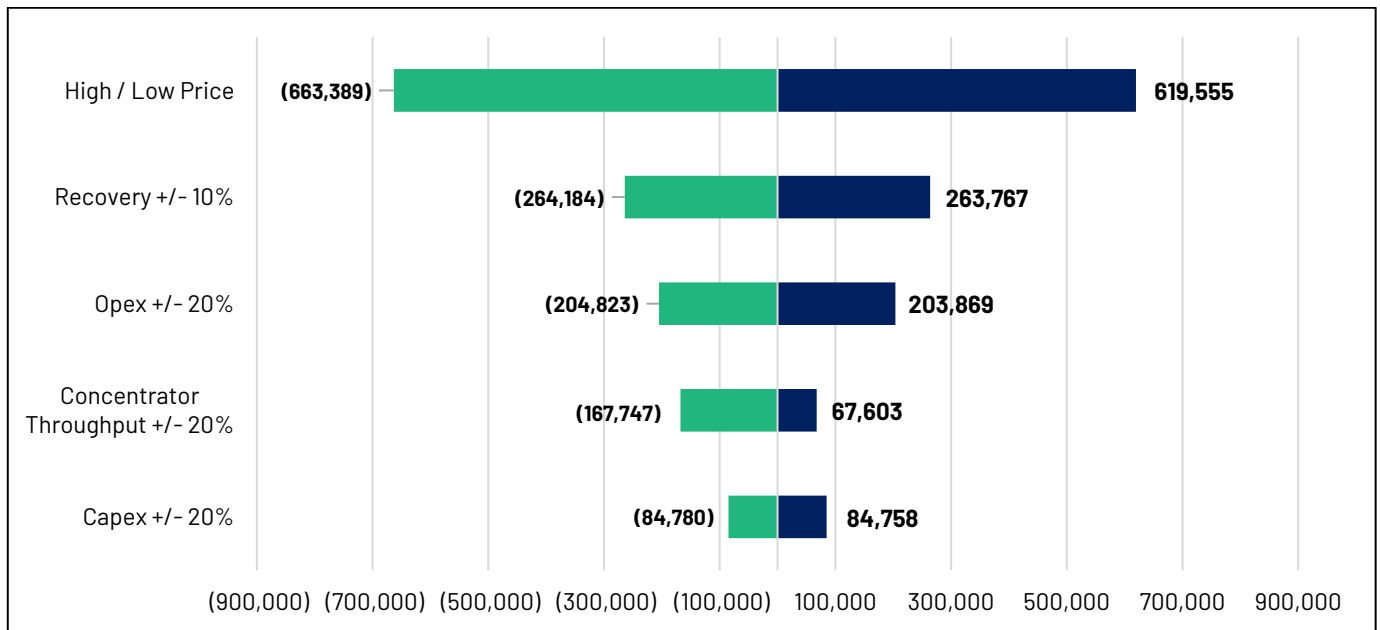

Figure 45: Mine and Concentrators Sensitivity Analysis

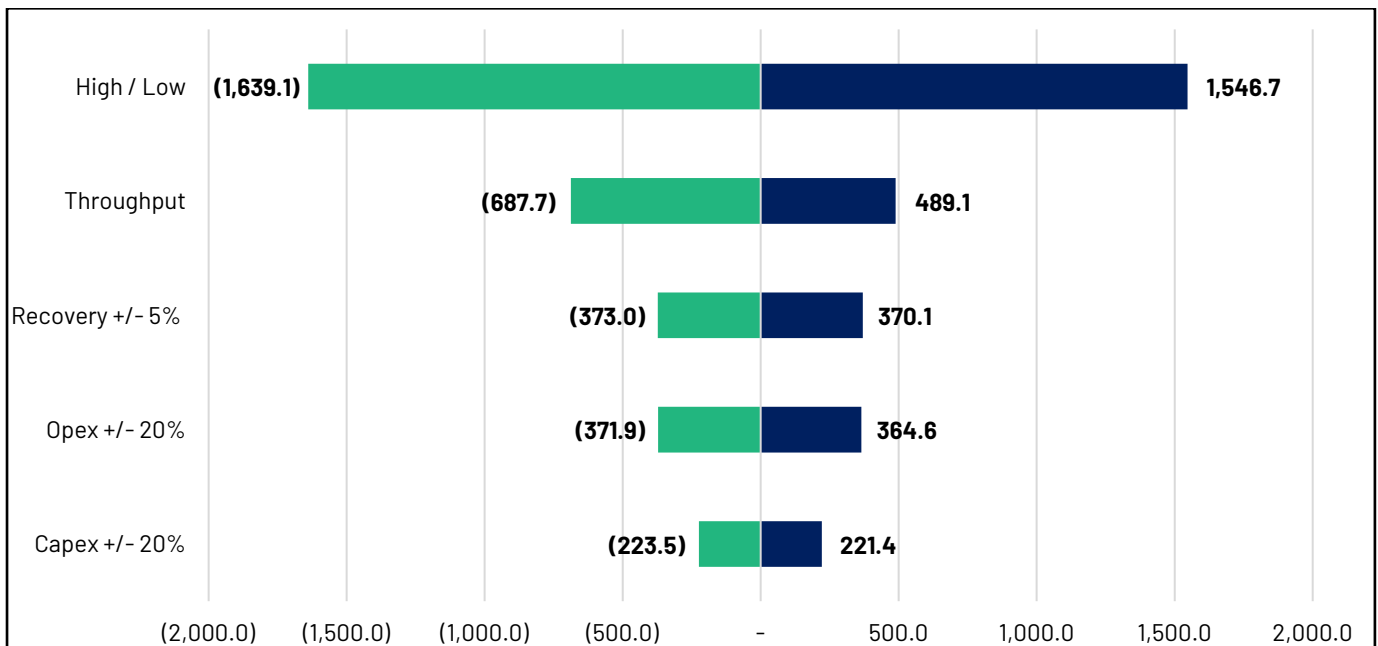

Figure 46: Integrated Project Sensitivity Analysis

### 1.18 Interpretation and Conclusions

The Project supports conventional and proven mining and spodumene concentration technology. The spodumene bearing ore will be extracted from open pits. The spodumene conversion to lithium hydroxide finished product is based on flowsheet technology developed and proposed by various vendors that is being utilized by multiple developers with facilities currently under construction.

## Preliminary Economic Assessment

The economic models have demonstrated reasonable prospects for economic mining, processing and conversion, with positive NPVs for both scenarios modelled for this PEA, being the mine and concentrator option and an integrated concentrator/conversion project strategy.

GT1 is committed to execute all phases of the Project in a socially and environmentally responsible manner. Focus has been placed on water management and visual impacts of the Seymour project infrastructure. The processing plant will recover water captured for re-use in processing to minimize the use of surface/underground water and will ensure all runoff is captured to prevent any discharge to the surrounding environment. Further, the open pit, stockpiles, concentrator and surrounding infrastructure is designed and positioned to minimize the footprint and impact to the visual landscape. These design components demonstrate the commitment to minimising social impacts that the development may have on the surrounding communities.

Similar practices have been planned and will be employed at other project sites for the remaining stages of the project and will be further studied in the next phases of development.

Project investment will provide positive social, economic and material supply strategic impacts locally and nationally, including job creation, training, procurement and business opportunity throughout the region, from construction through operations.

### 1.19 Recommendations

Given the favorable outcomes of this PEA, it is recommended that the company will move ahead with the proposed staged strategy. They are broken down as follows:

**Stage 1 – Seymour (Eastern Hub)** to progress to a Definitive Feasibility Study (DFS). As part of further assessment the following options studies outlined in this section may be performed early in the DFS phase.

- Geotechnical study to steepen Overall Slope Angle and significantly reduce waste removal and subsequent costs
- Whittle shell selection to reduce strip ratios and total material movement as a function of ore recovery
- Mining cost model optimisation focusing on ore and waste CAD contractor rates to reduce overall mining costs
- Detailed staged cutback pit design to smooth grade, total material movement and equipment selection
- Open Pit and underground cross-over study to recover the remaining resource inventory at Seymour
- Logistical/shipping studies to assess optimum transport handling and pricing for export
- Additional desk-top assessment of surrounding ore supplies from satellite ore bodies to Seymour concentrator
- Additional variability metallurgical testing to validate metallurgical parameters and support a DFS level design and cost estimates.
- Ore-sorting trials to reduce waste/dilution fed into the concentrator
- Modular supply and assembly of the processing facility vs insitu-build.
- Power generation trade off and supply selection.

Additional recommendations include:

- GT1 to focus on increasing mineral inventory and subsequently mine life by further exploration of the Junior Lithium project, acquisitions and off-take agreements.
- Continue with DFS concentrator testwork, and piloting of 100 tonne bulk sample.

**Stage 2 – Thunder Bay – Lithium Conversion Facility** to proceed to a Preliminary Feasibility Study (PFS) to further progress the development pathway. As part of those work streams the following is also proposed/recommended as part of the study.

- Complete bench scale conversion work to produce Lithium Hydroxide
- Continue site selection assessment studies, and remediation costs/conditions associated with the current site location

## Preliminary Economic Assessment

- Develop plans for processing the Seymour and Root concentrates at pilot scale – confirming flowsheet selection, by-products and further inputs/outputs
- Continue market assessment on production of hydroxide or carbonate and purity requirements
- Phasing out low grade feed from Seymour with high grade feed from Root, ultimately increasing the grade during this transition period

**Stage 3 – Root (Western Hub)** to proceed to PFS phase of assessment. As the timeframe for permitting is governed by baseline studies and potential federal permitting approvals this work can be progressed at a slower rate. Some additional tradeoffs that can be looked at in conjunction with the study:

- Geotechnical study to steepen Overall Slope Angle and significantly reduce waste removal and subsequent costs
- Detailed staged cutback design to smooth grade, total material movement and equipment selection
- New pit design and ramp system to minimize overall slope angle and reduce subsequent waste removal costs
- Open pit/underground study to potentially access Root deeps discovery. Additional drilling work required to establish UG resource potential, and development geometry.

Additional variability metallurgical testing to support a PFS for both Root Bay and McCombe pits.

- Optimised flow sheet development for coarser direct flotation – potential 'hydroflotation' and continue metallurgical testwork programs to optimize recovery.
- Ore sorting work to establish dilution reduction for open pit scenario.

## APPENDIX C: JORC CODE, 2012 EDITION – Table 1 Report

# JORC Code, 2012 Edition – Table 1 report template

## Section 1 Sampling Techniques and Data

(Criteria in this section apply to all succeeding sections.)

Criteria	JORC Code explanation	Commentary
<b>Sampling techniques</b>	<ul style="list-style-type: none"> <li>Nature and quality of sampling (eg cut channels, random chips, or specific specialised industry standard measurement tools appropriate to the minerals under investigation, such as down hole gamma sondes, or handheld XRF instruments, etc). These examples should not be taken as limiting the broad meaning of sampling.</li> <li>Include reference to measures taken to ensure sample representivity and the appropriate calibration of any measurement tools or systems used.</li> <li>Aspects of the determination of mineralisation that are Material to the Public Report.</li> <li>In cases where 'industry standard' work has been done this would be relatively simple (eg 'reverse circulation drilling was used to obtain 1 m samples from which 3 kg was pulverised to produce a 30 g charge for fire assay'). In other cases more explanation may be required, such as where there is coarse gold that has inherent sampling problems. Unusual commodities or mineralisation types (eg submarine nodules) may warrant disclosure of detailed information.</li> </ul>	<p><b>No drilling is reported in this release.</b></p> <p><b>Seymour Metallurgy</b></p> <p>Metallurgical samples from the North Aubry deposit within a USD2500 pit design were selected from 57 historic and GT1 drill hole ¼ core reserves for 888m.</p> <p>To reflect the proposed commercial design all material was stage crushed to -10 mm and screened at 6.3 mm and 0.85 mm, generating a coarse (-10 to 6.3 mm) and fine (-6.3 to 0.85 mm) size fraction for gravity separation and a fines bypass fraction (-0.85 mm) which reported to tailings.</p> <p>Two-stage gravity separation was performed at a primary specific gravity (SG) of 2.65 and secondary SG of 2.90. Middlings are material which sinks at SG 2.65 but floats at SG 2.90 and may contain significant lithium content; the coarse middlings were re-crushed to -6.3 mm to improve liberation. The re-crushed middlings were subsequently screened at 0.85 mm for fines bypass and with the plus size fraction being passed through two-stage gravity separation again, to reflect the proposed flowsheet.</p> <p>The coarse size fractions were processed using a pilot scale DMS plant. However, the fine size fractions and the entirety of the LG composite masses were insufficient to use the pilot scale DMS plant, therefore bulk HLS testing was used.</p> <p><b>Root Bay Metallurgy</b></p> <p>Preliminary metallurgy 1/2 NQ diameter core samples from the Root Bay deposit within a USD2500 pit design were selected from hole RB-23-001 drilled by GT1 for 79.7m.</p>
<b>Drilling techniques</b>	<ul style="list-style-type: none"> <li>Drill type (eg core, reverse circulation, open-hole hammer, rotary air blast, auger, Bangka, sonic, etc) and details (eg core diameter, triple or standard tube, depth of diamond tails, face-sampling bit or other type, whether core is oriented and if so, by what method, etc).</li> </ul>	<p><b>No drilling is reported in this release.</b></p>
<b>Drill sample recovery</b>	<ul style="list-style-type: none"> <li>Method of recording and assessing core and chip sample recoveries and results assessed.</li> <li>Measures taken to maximise sample recovery and ensure representative nature of the samples.</li> <li>Whether a relationship exists between sample recovery and grade and whether sample bias may have occurred due to preferential loss/gain of fine/coarse material.</li> </ul>	<p><b>No drilling is reported in this release.</b></p>
<b>Logging</b>	<ul style="list-style-type: none"> <li>Whether core and chip samples have been</li> </ul>	<p><b>No drilling is reported in this release.</b></p>

Criteria	JORC Code explanation	Commentary
	<p>geologically and geotechnically logged to a level of detail to support appropriate Mineral Resource estimation, mining studies and metallurgical studies.</p> <ul style="list-style-type: none"> <li>▪ Whether logging is qualitative or quantitative in nature. Core (or costean, channel, etc) photography.</li> <li>▪ The total length and percentage of the relevant intersections logged.</li> </ul>	
<b>Sub-sampling techniques and sample preparation</b>	<ul style="list-style-type: none"> <li>▪ If core, whether cut or sawn and whether quarter, half or all core taken.</li> <li>▪ If non-core, whether riffled, tube sampled, rotary split, etc and whether sampled wet or dry.</li> <li>▪ For all sample types, the nature, quality and appropriateness of the sample preparation technique.</li> <li>▪ Quality control procedures adopted for all sub-sampling stages to maximise representivity of samples.</li> <li>▪ Measures taken to ensure that the sampling is representative of the in situ material collected, including for instance results for field duplicate/second-half sampling.</li> <li>▪ Whether sample sizes are appropriate to the grain size of the material being sampled.</li> </ul>	<b>No drilling is reported in this release.</b>
<b>Quality of assay data and laboratory tests</b>	<ul style="list-style-type: none"> <li>▪ The nature, quality and appropriateness of the assaying and laboratory procedures used and whether the technique is considered partial or total.</li> <li>▪ For geophysical tools, spectrometers, handheld XRF instruments, etc, the parameters used in determining the analysis including instrument make and model, reading times, calibrations factors applied and their derivation, etc.</li> <li>▪ Nature of quality control procedures adopted (eg standards, blanks, duplicates, external laboratory checks) and whether acceptable levels of accuracy (ie lack of bias) and precision have been established.</li> </ul>	<b>No drilling is reported in this release.</b>
<b>Verification of sampling and assaying</b>	<ul style="list-style-type: none"> <li>▪ The verification of significant intersections by either independent or alternative company personnel.</li> <li>▪ The use of twinned holes.</li> <li>▪ Documentation of primary data, data entry procedures, data verification, data storage (physical and electronic) protocols.</li> <li>▪ Discuss any adjustment to assay data.</li> </ul>	<b>No drilling is reported in this release.</b>
<b>Location of data points</b>	<ul style="list-style-type: none"> <li>▪ Accuracy and quality of surveys used to locate drill holes (collar and down-hole surveys), trenches, mine workings and other locations used in Mineral Resource estimation.</li> <li>▪ Specification of the grid system used.</li> <li>▪ Quality and adequacy of topographic control.</li> </ul>	<ul style="list-style-type: none"> <li>▪ A GPS reading was taken for each sample location using UTM NAD83 Zone16 (for Seymour); waypoint averaging or dGPS was performed when possible.</li> <li>▪ The project area was flown using LIDAR equipment in October 2021 by KBM Resources Group Inc. from Thunder Bay using a Riegl 680i LiDAR system, coupled to a Applanix POSAV 510 positioning system. The topographic mapping produced is extremely accurate and well suited for resource modelling.</li> <li>▪ All drilling collars coordinates were compared to the Lidar elevation data to ensure no erroneous coordinates were present in the database. Some collar RL's were adjusted to the Lidar elevation where they differed by more than 3m. GT1 employed a calibrated Reflex SprintIQ North Seeking Gyroscopic tool on all 2021 and 2022 drill holes and surveyed the holes in their entirety with readings downhole every 5m. North Seeking gyroscopes have a typical azimuth accuracy of +/-0.75 degrees and +/-0.15 degrees for dip.</li> </ul>

Criteria	JORC Code explanation	Commentary
----------	-----------------------	------------

		<p><b>Seymour Metallurgy</b></p> <p>Location of the North Aubry metallurgical samples coloured by assigned ore type within a USD2500 pit design:</p>  <p><b>Root Bay Metallurgy</b></p> <p>Location of the Root Bay pegmatite metallurgical samples within a USD2500 pit design:</p> 
--	--	--

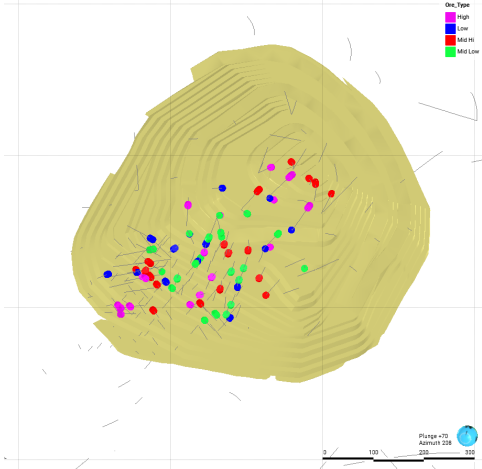
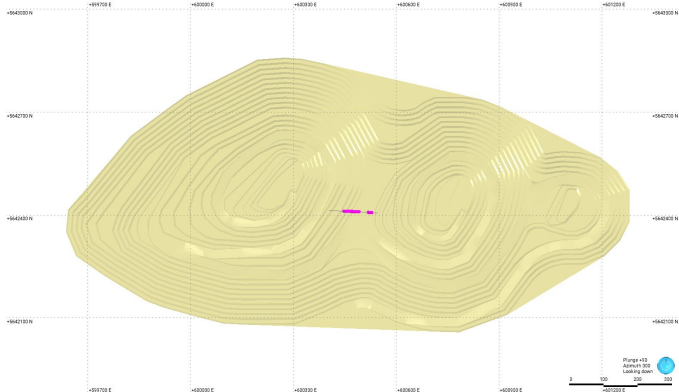
		<p><b>Seymour Metallurgy</b></p> <p>Location of the North Aubry metallurgical samples coloured by assigned ore type within a USD2500 pit design:</p>  <p><b>Root Bay Metallurgy</b></p> <p>Location of the Root Bay pegmatite metallurgical samples within a USD2500 pit design:</p> 
--	--	--

<b>Data spacing and distribution</b>	<ul style="list-style-type: none"> <li>Data spacing for reporting of Exploration Results.</li> <li>Whether the data spacing and distribution is sufficient to establish the degree of geological and grade continuity appropriate for the Mineral Resource and Ore Reserve estimation procedure(s) and classifications applied.</li> <li>Whether sample compositing has been applied.</li> </ul>	<p><b>Seymour Metallurgy</b></p> <ul style="list-style-type: none"> <li>All available historic and more recent GT1 drill core was used to provide metallurgical testwork samples. The samples were distributed roughly on a 50m SE x 100m NW grid with closer spaced shallower samples.</li> </ul> <p><b>Root Bay Metallurgy</b></p> <ul style="list-style-type: none"> <li>A single hole, RB-23-001, was chosen to provide indicative metallurgical testwork intersecting two pegmatites, (RB001 and RB002) within the USD2500 pit design.</li> </ul>
--------------------------------------	--	--

		<p><b>Seymour Metallurgy</b></p> <ul style="list-style-type: none"> <li>GT1 drill samples were drilled close to perpendicular to the strike of the pegmatite unit and sampled the entire length of the pegmatite as well including several metres into the mafic country rock either side of the pegmatite.</li> </ul> <p><b>Root Bay Metallurgy</b></p> <ul style="list-style-type: none"> <li>Hole RB-23-001 was drilled downdip along the pegmatites and is not representative of the pegmatite true width.</li> </ul>
--	--	---

<b>Orientation of data in relation to geological structure</b>	<ul style="list-style-type: none"> <li>Whether the orientation of sampling achieves unbiased sampling of possible structures and the extent to which this is known, considering the deposit type.</li> <li>If the relationship between the drilling orientation and the orientation of key mineralised structures is considered to have introduced a sampling bias, this should be assessed and reported if material.</li> </ul>	<p><b>Seymour Metallurgy</b></p> <ul style="list-style-type: none"> <li>GT1 drill samples were drilled close to perpendicular to the strike of the pegmatite unit and sampled the entire length of the pegmatite as well including several metres into the mafic country rock either side of the pegmatite.</li> </ul> <p><b>Root Bay Metallurgy</b></p> <ul style="list-style-type: none"> <li>Hole RB-23-001 was drilled downdip along the pegmatites and is not representative of the pegmatite true width.</li> </ul>
--	--	---

		<p><b>Seymour Metallurgy</b></p> <ul style="list-style-type: none"> <li>GT1 drill samples were drilled close to perpendicular to the strike of the pegmatite unit and sampled the entire length of the pegmatite as well including several metres into the mafic country rock either side of the pegmatite.</li> </ul> <p><b>Root Bay Metallurgy</b></p> <ul style="list-style-type: none"> <li>Hole RB-23-001 was drilled downdip along the pegmatites and is not representative of the pegmatite true width.</li> </ul>
--	--	---

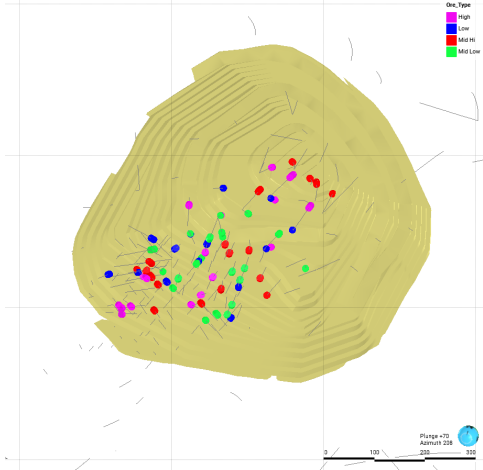
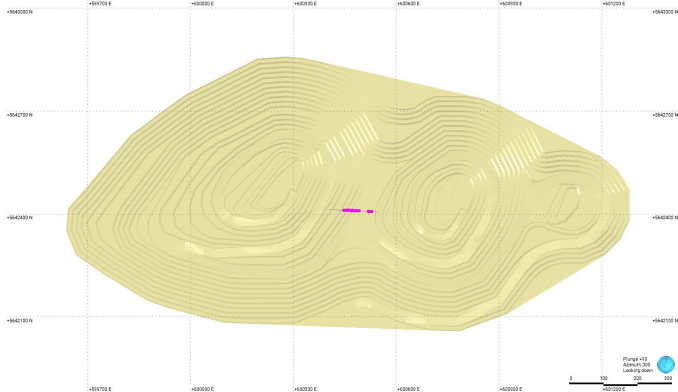
		<p><b>Seymour Metallurgy</b></p> <p>Location of the North Aubry metallurgical samples coloured by assigned ore type within a USD2500 pit design:</p>  <p><b>Root Bay Metallurgy</b></p> <p>Location of the Root Bay pegmatite metallurgical samples within a USD2500 pit design:</p> 
--	--	--

		<p><b>Seymour Metallurgy</b></p> <ul style="list-style-type: none"> <li>All available historic and more recent GT1 drill core was used to provide metallurgical testwork samples. The samples were distributed roughly on a 50m SE x 100m NW grid with closer spaced shallower samples.</li> </ul> <p><b>Root Bay Metallurgy</b></p> <ul style="list-style-type: none"> <li>A single hole, RB-23-001, was chosen to provide indicative metallurgical testwork intersecting two pegmatites, (RB001 and RB002) within the USD2500 pit design.</li> </ul>
--	--	--

		<p><b>Seymour Metallurgy</b></p> <ul style="list-style-type: none"> <li>GT1 drill samples were drilled close to perpendicular to the strike of the pegmatite unit and sampled the entire length of the pegmatite as well including several metres into the mafic country rock either side of the pegmatite.</li> </ul> <p><b>Root Bay Metallurgy</b></p> <ul style="list-style-type: none"> <li>Hole RB-23-001 was drilled downdip along the pegmatites and is not representative of the pegmatite true width.</li> </ul>
--	--	---



Criteria	JORC Code explanation	Commentary
<b>Sample security</b>	<ul style="list-style-type: none"> <li>The measures taken to ensure sample security.</li> </ul>	<p><b>Seymour and Root Metallurgy</b></p> <ul style="list-style-type: none"> <li>All core and samples were supervised and secured in a locked vehicle, warehouse, or container until delivered to the testing laboratory, either to Actlabs or AGAT in Thunder Bay for cutting, preparation and analysis.</li> </ul> <p><b>Seymour Metallurgy</b></p> <ul style="list-style-type: none"> <li>Historic and GT1½ core was either cut in GT1's Thunder Bay core storage facility or delivered under GT1 supervision to Diamond Daves', Thunder Bay, a core cutting contractor. Samples were ¼ core cut using a diamond saw and composited into nominally 1m lengths retained in numbered calico bags themselves grouped into labelled poly weave bags for delivery to the metallurgical laboratory.</li> </ul> <p><b>Root Bay Metallurgy</b></p> <p>Diamond hole RB-23-001 was ½ core cut by GT1 using a diamond saw and composited into nominally 1m lengths retained in numbered calico bags themselves grouped into labelled poly weave bags for delivery to the metallurgical laboratory.</p>
<b>Audits or reviews</b>	<ul style="list-style-type: none"> <li>The results of any audits or reviews of sampling techniques and data.</li> </ul>	<b>No drilling is reported in this release.</b>

## Section 2 Reporting of Exploration Results

(Criteria listed in the preceding section also apply to this section.)

Criteria	JORC Code explanation	Commentary
<b>Mineral tenement and land tenure status</b>	<ul style="list-style-type: none"> <li>Type, reference name/number, location and ownership including agreements or material issues with third parties such as joint ventures, partnerships, overriding royalties, native title interests, historical sites, wilderness or national park and environmental settings.</li> <li>The security of the tenure held at the time of reporting along with any known impediments to obtaining a licence to operate in the area.</li> </ul>	<p><b>Seymour and Root</b></p> <ul style="list-style-type: none"> <li>Green Technology Metals (ASX:GT1) owns 100% interest in the Ontario Lithium Projects (Seymour, Junior, Root and Wisa).</li> <li>Seymour Lithium Asset consists of 744 Cell Claims (Exploration Licences) with a total claim area of 15,140 ha.</li> <li>The Root Lithium Asset consists of 249 boundary Cell mining claims (Exploration Licences), 33 mining license of occupation claims (285 total claims) with a total claim area of 5,377 ha.</li> <li>GT1 have acquired several additional claims around Seymour, Root, Allison Lake and Landore since listing on the ASX.</li> <li>As of the effective date of this report, all subject lands are in good standing and all claims are currently held 100% by Green TM Resources (Canada) Ltd (a subsidiary of Green Technology Metals Ltd).</li> <li>Seymour claims are on Crown Land, surface access is guaranteed under the Mining Act of Ontario.</li> <li>Generally surface rights to the Root Property remain with the Crown, except for 9 Patent Claims (PAT-51965. PAT-51966. PAT-51967. PAT-51968. PAT-51970. PAT-51974. PAT-51975. PAT-51976 and PAT-51977).</li> <li>All Cell Claims are in good standing</li> <li>An Active Exploration Permit exists over the Seymour and Root Lithium Assets</li> <li>An Exploration Agreement is current with the Whitesand First Nation who are supportive of GT1 exploration activities.</li> </ul>
<b>Exploration done by other parties</b>	<ul style="list-style-type: none"> <li>Acknowledgment and appraisal of exploration by other parties.</li> </ul>	<p><b>Seymour</b></p> <ul style="list-style-type: none"> <li>Regional exploration for lithium deposits commenced in the 1950's. In 1957, local prospector, Mr Nelson Aubry, discovered the North Aubry and the South Aubry pegmatites.</li> <li>Geological mapping by the Ontario Department of Mines commenced in 1959 and was completed in 1962 (Pye, 1968), with the publication of "Map 2100 Crescent Lake Area" in 1965.</li> <li>From the late 1950's to 2002, exploration by the Ontario Department of Mines was generally restricted to geological mapping and surface sampling, although some minor drilling was completed to test the North Aubry pegmatite in late 1957 (Rees, 2011).</li> <li>In 2001, Linear Resources Inc. ("Linear Resources") obtained the Seymour Lake Project with an initial focus on the project's tantalum potential. In 2002, a 23-diamond drill-hole campaign was completed at North Aubry, and</li> </ul>

Criteria	JORC Code explanation	Commentary
		<p>a further 8 diamond drill-holes at South Aubry.</p> <ul style="list-style-type: none"> <li>▪ In 2008, Linear Resources completed a regional soil-sampling program which resulted in the identification of a number soil geochemical anomalies. Based on these anomalies, another drilling campaign (completed in 2009), with 12 diamond drill-holes at North Aubry, 2 diamond drill-holes at South Aubry, and further 5 diamond drill-holes peripheral to the Aubry prospects designed to test the main 2008 soil geochemical anomalies.</li> <li>▪ Little work was undertaken between 2010 and 2016 until Ardiden acquired the project from Linear Resources in 2016. Further drilling was carried out by Ardiden between 2017 and 2018 resulting in the completion of an updated mineral resource estimate of the Aubry pegmatites in 2018. Ground Penetrating Radar (GPR) was also undertaken by Ardiden in 2018 to test any further exploration potential beyond the current Aubry pegmatite delineating numerous targets.</li> </ul> <p><b>Root</b></p> <ul style="list-style-type: none"> <li>▪ Regional exploration for lithium deposits commenced in the 1950's.</li> <li>▪ In 1955-1956 Capital Lithium Mines Ltd. geologically mapped and sampled dikes near the McCombe Deposit with the highest recorded channel sample of 1.52m at 3.06%Li<sub>2</sub>O. 7 drill holes (1,042.26m total) within the McCombe Deposit and Root Lake Prospect yielding low lithium assays. According to Mulligan (1965), Capital Lithium Mines Ltd. reported to Mulligan that they drilled at least 55 holes totalling 10469.88m in 1956. They delineated 4 pegmatite zones and announced a non-compliant NI 41-101 reserve calculation of 2.297 million tons at 1.3% Li<sub>2</sub>O. However, none of that information is available on the government database.</li> <li>▪ In 1956, Consolidated Morrison Explorations Ltd drilled 16 holes (1890m total) at the Morrison prospect recording 3.96m at 2.63% Li<sub>2</sub>O.</li> <li>▪ In 1956, Three Brothers Mining Exploration southwest of the McCombe Deposit that did not intersect pegmatite</li> <li>▪ In 1957, Geo-Technical Development Company Limited on behalf of Continental Mining Exploration conducted a magnetometer survey and an electromagnetic check survey on the eastern claims of the Root Lithium Project to locate pyrrhotite mineralization</li> <li>▪ In 1977, Northwest Geophysics Limited on behalf of Noranda Exploration Company Ltd. conducted an electromagnetic and magnetometer survey for sulphide conductors on a small package of claims east of the Morrison Prospect. Noranda also conducted a mapping and sampling program over the same area, mapped a new pegmatite dike and sampled a graphitic schist assaying 0.03% Cu and 0.15% Zn.</li> <li>▪ In 1998, Harold A. Watts prospected, trenched and sampled spodumene-bearing pegmatites with the Morrison Prospect assaying up to 5.91% Li<sub>2</sub>O. In 2002 stripped and blasted 2 more spodumene-bearing pegmatites near the Morrison prospect.</li> <li>▪ In 2005, Landore Resources Canada Inc. created a reconnaissance survey, mapping and sampling project mostly within the McCombe Deposit, but also in the Morrison and Root Lake Prospects. Highest sample was 3.69% Li<sub>2</sub>O with the McCombe Deposit.</li> <li>▪ In 2008, Rockex Ltd. on behalf of Robert Allan Ross stripped and trenched 40 trenches for iron, gold and base metals associated with oxide iron formation. All Fe assays were above 25% (up to 47.5% Fe). 3 gold zones were discovered with assays up to 4.0g/t Au in Zone A (Root Bay Gold Prospect), 1.3%g/t Au over 0.5m in Trench 9, 0.19% Cu-Zn over 8m and up to 0.14% Li<sub>2</sub>O in Zone B. Best assays of samples collected north-east area of Root Bay had up to 394ppm Zn, 389ppm Cu, 185ppm Ni, 102ppm Co and 57.0ppm Mo.</li> <li>▪ In 2009, Golden Dory Resources along with Harold A. Watts conducted a due diligence sampling program to validate historic data from the Morrison Prospect. Highest grab sample was 5.10% Li<sub>2</sub>O and a channel sample of 5m at 4.44% Li<sub>2</sub>O.</li> </ul>

Criteria	JORC Code explanation	Commentary
		<ul style="list-style-type: none"> <li>▪ In 2011, Geo Data Solutions GDS Inc. on behalf of Rockex Ltd. flew a high-resolution helicopter borne aeromagnetic survey intersecting a small portion of the south-central claims owned by GM1.</li> <li>▪ In 2012, Stares Contracting on behalf of Golden Dory Resources Corporation conducted a ground magnetic survey near the Morrison Prospect to look for magnetic contrasts between pegmatites and metasedimentary units. They also conducted a prospecting (lithium) and soil sampling (gold) program at the Rook Lake Prospect and east of the Morrison Prospect. Highest Li assays within GM1 claims was 0.0037% Li<sub>2</sub>O and a gold soil assay of 52ppb Au.</li> <li>▪ In 2016, the previous owner conducted a drilled 7 diamond drill holes (469m total) within the McCombe deposit. Highest assay was 1m at 3.8% Li<sub>2</sub>O. A hole drilled down dip intersected 70m at 1.7% Li<sub>2</sub>O. An outcrop sampling within the Morrison and Root Bay Prospects yielded 0.04% Li<sub>2</sub>O. Channel sample within the Morrison Prospect had 5m at 2.09% Li<sub>2</sub>O and within the Root Bay Prospect, 14m at 1.67% Li<sub>2</sub>O.</li> <li>▪ In 2021, KBM Resources Group on behalf of Kenorland Minerals North America Ltd. conducted an 800km<sup>2</sup> aerial LIDAR acquisition survey over their South Uchi Property which intersects a very small portion of the patented claims held by GM1, just west of the McCombe Deposit.</li> </ul>
<b>Geology</b>	<ul style="list-style-type: none"> <li>▪ <i>Deposit type, geological setting and style of mineralisation.</i></li> </ul>	<p><b>Seymour</b></p> <ul style="list-style-type: none"> <li>▪ <b>Regional Geology:</b> The general geological setting of the Seymour Lithium Asset consists of the Precambrian Canadian Shield that underlies approximately 60% of Ontario. The Shield can be divided into three major geological and physiographic regions, from the oldest in the northwest to the youngest in the southeast.</li> <li>▪ <b>Local Geology:</b> The Seymour Lithium Asset is located within the eastern part of the Wabigoon Subprovince, near the boundary with the English River Subprovince to the north. These subprovinces are part of the Superior Craton, comprised mainly of Archaean rocks but also containing some Mesoproterozoic rocks such as the Nipigon Diabase.</li> <li>▪ <b>Bedrock Geology:</b> The bedrock is best exposed along the flanks of steep-sided valleys scoured by glaciers during the recent ice ages. The exposed bedrock is commonly metamorphosed basaltic rock, of which some varieties have well-preserved pillows that have been intensely flattened in areas of high tectonic strain. Intercalated between layers of basalt are lesser amounts of schists derived from sedimentary rocks and lesser rocks having felsic volcanic protoliths. These rocks are typical of the Wabigoon Subprovince, host to most of the pegmatites in the region.</li> <li>▪ <b>Ore Geology:</b> Pegmatites are reasonably common in the region intruding the enclosing host rocks after metamorphism, evident from the manner in which the pegmatites cut across the well-developed foliation within the metamorphosed host rocks. This post-dating relationship is supported by radiometric dating; an age of 2666 ± 6 Ma is given for the timing of intrusion of the pegmatites (Breaks, et al., 2006).</li> <li>▪ The pegmatites in North Aubry have a northeast plunge direction varying from 10 to 35 degrees from horizontal some 800m downdip extent and 250-300m strike. The North Upper and North Upper high grade component within, appears to wedge towards the south east and is still open down dip and to the north west.</li> <li>▪ Southern pegmatites are thinner and less well developed with higher muscovite content and appear to have a more north to north-westerly trend and dip more shallowly to the east. These pegmatites are also hosted in pillow basalts.</li> <li>▪ The pegmatites are zoned with better developed spodumene crystal appearing as bands, often at an acute angle to the general trend of the pegmatite.</li> <li>▪ The dominant economic minerals are spodumene with varying proportions of muscovite, microcline, and minor petalite and lepidolite.</li> <li>▪ The adjacent pillow basalts contain minor disseminated pyrite and pyrrhotite.</li> </ul> <p><b>Root</b></p>

Criteria	JORC Code explanation	Commentary																																																																																																		
		<ul style="list-style-type: none"> <li>▪ <b>Regional Geology:</b> The Root Lithium Asset is located within the Uchi Domain, predominately metavolcanic units interwoven with granitoid batholiths and English River Terrane, a highly metamorphosed to migmatized, clastic and chemical metasedimentary rock with abundant granitoid batholiths. They are part of the Superior craton, interpreted to be the amalgamation of Archean aged microcontinents and accretionary events. The boundary between the Uchi Domain and the English River Terrane is defined by the Sydney Lake – Lake St. Joseph fault, an east west trending, steeply dipping brittle ductile shear zone over 450km along strike and 1 – 3m wide. Several S-Type, peraluminous granitic plutons host rare-element mineralization near the Uchi Domain and English River subprovince boundary. These pegmatites include the Root Lake Pegmatite Group, Jubilee Lake Pegmatite Group, Sandy Creek Pegmatite and East Pashkokogan Lake Lithium Pegmatite.</li> <li>▪ <b>Local Geology:</b> The Root Lithium Asset contains most of the pegmatites within the Root Lake Pegmatite Group including the McCombe Pegmatite, Morrison Prospect, Root Lake Prospect and Root Bay Prospect. The McCombe Pegmatite and Morrison Prospect are hosted in predominately mafic metavolcanic rock of the Uchi Domain. The Root Lake and Root Bay Prospects are hosted in predominately metasedimentary rocks of the English River Terrane. On the eastern end of the Root Lithium Asset there is a gold showing (Root Bay Gold Prospect) hosted in or proximal to silicate, carbonate, sulphide, and oxide iron formations of the English River Terrane.</li> <li>▪ <b>Ore Geology:</b> The McCombe Pegmatite is internally zoned. These zones are classified by the tourmaline discontinuous zone along the pegmatite contact, white feldspar-rich wall zone, tourmaline-bearing, equigranular to porphyritic potassium feldspar sodic apalite zone, tourmaline-bearing, porphyritic potassium feldspar spodumene pegmatite zone and lepidolite-rich pods and seams (Breaks et al., 2003). The Root project pegmatites have been classified as complex-type, spodumene-subtype (Černý 1991a classification) based on the abundance of spodumene, highly evolved potassium feldspar chemistry and presence of petalite, microlite, lepidolite and lithium-calcium liddicoatite (Breaks et al., 2003).</li> </ul>																																																																																																		
<b>Drill hole Information</b>	<ul style="list-style-type: none"> <li>▪ A summary of all information material to the understanding of the exploration results including a tabulation of the following information for all Material drill holes: <ul style="list-style-type: none"> <li>○ easting and northing of the drill hole collar</li> <li>○ elevation or RL (Reduced Level – elevation above sea level in metres) of the drill hole collar</li> <li>○ dip and azimuth of the hole</li> <li>○ down hole length and interception depth</li> <li>○ hole length.</li> </ul> </li> <li>▪ If the exclusion of this information is justified on the basis that the information is not Material and this exclusion does not detract from the understanding of the report, the Competent Person should clearly explain why this is the case.</li> </ul>	<p><b>Seymour Metallurgy</b></p> <p>57 holes within the North Aubry USD2500 pit design were used for metallurgical work, with the following collar coordinates:</p> <table border="1" data-bbox="737 1367 1484 1942"> <thead> <tr> <th>Holeid</th> <th>Northing</th> <th>Easting</th> <th>RL</th> <th>Depth</th> <th>Azi</th> <th>Dip</th> </tr> </thead> <tbody> <tr><td>ASD001</td><td>5,585,210</td><td>397,034</td><td>395</td><td>158</td><td>89</td><td>- 89</td></tr> <tr><td>ASD002</td><td>5,585,294</td><td>397,017</td><td>378</td><td>156</td><td>200</td><td>- 70</td></tr> <tr><td>ASD003</td><td>5,585,336</td><td>397,067</td><td>375</td><td>201</td><td>202</td><td>- 73</td></tr> <tr><td>ASD004</td><td>5,585,364</td><td>397,114</td><td>379</td><td>228</td><td>195</td><td>- 71</td></tr> <tr><td>ASD005</td><td>5,585,364</td><td>397,114</td><td>379</td><td>291</td><td>202</td><td>- 85</td></tr> <tr><td>ASD006</td><td>5,585,298</td><td>397,174</td><td>388</td><td>200</td><td>201</td><td>- 75</td></tr> <tr><td>ASD007</td><td>5,585,297</td><td>397,173</td><td>388</td><td>251</td><td>201</td><td>- 85</td></tr> <tr><td>ASD008A</td><td>5,585,353</td><td>397,224</td><td>390</td><td>240</td><td>206</td><td>- 72</td></tr> <tr><td>ASD009</td><td>5,585,353</td><td>397,225</td><td>390</td><td>258</td><td>219</td><td>- 85</td></tr> <tr><td>ASD010</td><td>5,585,405</td><td>397,164</td><td>391</td><td>264</td><td>196</td><td>- 72</td></tr> <tr><td>ASD011</td><td>5,585,405</td><td>397,164</td><td>391</td><td>330</td><td>196</td><td>- 86</td></tr> <tr><td>ASD012</td><td>5,585,334</td><td>397,069</td><td>375</td><td>201</td><td>197</td><td>- 54</td></tr> <tr><td>ASD013</td><td>5,585,334</td><td>397,069</td><td>375</td><td>189</td><td>185</td><td>- 61</td></tr> </tbody> </table>	Holeid	Northing	Easting	RL	Depth	Azi	Dip	ASD001	5,585,210	397,034	395	158	89	- 89	ASD002	5,585,294	397,017	378	156	200	- 70	ASD003	5,585,336	397,067	375	201	202	- 73	ASD004	5,585,364	397,114	379	228	195	- 71	ASD005	5,585,364	397,114	379	291	202	- 85	ASD006	5,585,298	397,174	388	200	201	- 75	ASD007	5,585,297	397,173	388	251	201	- 85	ASD008A	5,585,353	397,224	390	240	206	- 72	ASD009	5,585,353	397,225	390	258	219	- 85	ASD010	5,585,405	397,164	391	264	196	- 72	ASD011	5,585,405	397,164	391	330	196	- 86	ASD012	5,585,334	397,069	375	201	197	- 54	ASD013	5,585,334	397,069	375	189	185	- 61
Holeid	Northing	Easting	RL	Depth	Azi	Dip																																																																																														
ASD001	5,585,210	397,034	395	158	89	- 89																																																																																														
ASD002	5,585,294	397,017	378	156	200	- 70																																																																																														
ASD003	5,585,336	397,067	375	201	202	- 73																																																																																														
ASD004	5,585,364	397,114	379	228	195	- 71																																																																																														
ASD005	5,585,364	397,114	379	291	202	- 85																																																																																														
ASD006	5,585,298	397,174	388	200	201	- 75																																																																																														
ASD007	5,585,297	397,173	388	251	201	- 85																																																																																														
ASD008A	5,585,353	397,224	390	240	206	- 72																																																																																														
ASD009	5,585,353	397,225	390	258	219	- 85																																																																																														
ASD010	5,585,405	397,164	391	264	196	- 72																																																																																														
ASD011	5,585,405	397,164	391	330	196	- 86																																																																																														
ASD012	5,585,334	397,069	375	201	197	- 54																																																																																														
ASD013	5,585,334	397,069	375	189	185	- 61																																																																																														

Criteria	JORC Code explanation	Commentary						
		ASD015	5,585,111	397,116	386	96	52	- 85
		ASD017	5,585,211	397,199	388	159	203	- 69
		ASD019	5,585,287	397,261	389	201	201	- 70
		GTDD-21-0004	5,585,452	397,241	388	341	213	- 74
		GTDD-21-0005	5,585,400	397,275	351	372	221	- 80
		GTDD-22-0001	5,585,304	397,013	379	201	276	- 78
		GTDD-22-0002	5,585,390	397,048	336	312	191	- 75
		GTDD-22-0003	5,585,451	397,136	391	403	194	- 77
		GTDD-22-0015	5,585,475	397,203	392	395	217	- 75
		GTDD-22-0016	5,585,422	397,256	388	350	224	- 77
		SL-16-49	5,585,113	396,997	400	52	271	- 60
		SL-16-57	5,585,111	396,912	385	50	267	- 60
		SL-16-58	5,585,115	396,937	387	51	263	- 59
		SL-16-62	5,585,177	396,967	395	105	260	- 60
		SL-16-63	5,585,167	396,994	397	105	266	- 62
		SL-16-71	5,585,169	397,028	397	102	258	- 60
		SL-16-72	5,585,154	396,858	379	101	116	- 80
		SL-17-05	5,585,107	396,913	385	131	94	- 61
		SL-17-06	5,585,094	396,915	384	111	99	- 59
		SL-17-11	5,585,165	396,885	378	107	89	- 60
		SL-17-13	5,585,208	396,887	377	121	88	- 61
		SL-17-14	5,585,206	396,954	396	118	203	- 59
		SL-17-21	5,585,211	397,019	396	144	199	- 59
		SL-17-22	5,585,225	396,938	390	123	153	- 58
		SL-17-24	5,585,275	396,897	377	140	142	- 60
		SL-17-37	5,585,267	397,008	389	140	211	- 60
		SL-17-42	5,585,179	397,076	384	123	219	- 61
		SL-17-45	5,585,214	397,105	384	125	197	- 59
		SL-17-49	5,585,196	397,137	392	120	201	- 58
		SL-17-50	5,585,167	397,128	389	114	198	- 61
		SL-17-53	5,585,230	397,091	385	114	207	- 59
		SL-17-57	5,585,230	397,133	391	120	191	- 62
		SL-17-60	5,585,261	397,123	390	129	199	- 60
		SL-17-62	5,585,250	397,145	393	129	201	- 59
		SL-17-63	5,585,277	397,058	379	120	199	- 62
		SL-17-65	5,585,265	397,186	393	150	203	- 60
		SL-17-66	5,585,275	397,147	392	141	200	- 61
		SL-17-67	5,585,298	397,113	389	153	202	- 61
		SL-17-69	5,585,317	397,100	387	156	199	- 61
		SL-17-71	5,585,309	397,142	387	165	196	- 64
		SL-17-72	5,585,110	397,110	387	120	263	- 61
		SL-17-75	5,585,125	397,130	388	108	264	- 63

Criteria	JORC Code explanation	Commentary																												
		<table border="1"> <tr> <td>SL-17-76</td> <td>5,585,143</td> <td>397,088</td> <td>385</td> <td>81</td> <td>261</td> <td>- 64</td> </tr> <tr> <td>SL-17-77</td> <td>5,585,147</td> <td>397,066</td> <td>388</td> <td>75</td> <td>241</td> <td>- 62</td> </tr> </table> <p><b>Root Metallurgy</b></p> <p>1 hole within the Root Bay USD2500 pit design was used for metallurgical work, with the following collar coordinates:</p> <table border="1"> <thead> <tr> <th>Holeid</th> <th>Northing</th> <th>Easting</th> <th>RL</th> <th>Depth</th> <th>Azi</th> <th>Dip</th> </tr> </thead> <tbody> <tr> <td>RB-23-001</td> <td>5,642,412</td> <td>600,403</td> <td>434</td> <td>204</td> <td>90</td> <td>- 46</td> </tr> </tbody> </table>	SL-17-76	5,585,143	397,088	385	81	261	- 64	SL-17-77	5,585,147	397,066	388	75	241	- 62	Holeid	Northing	Easting	RL	Depth	Azi	Dip	RB-23-001	5,642,412	600,403	434	204	90	- 46
SL-17-76	5,585,143	397,088	385	81	261	- 64																								
SL-17-77	5,585,147	397,066	388	75	241	- 62																								
Holeid	Northing	Easting	RL	Depth	Azi	Dip																								
RB-23-001	5,642,412	600,403	434	204	90	- 46																								
<b>Data aggregation methods</b>	<ul style="list-style-type: none"> <li>In reporting Exploration Results, weighting averaging techniques, maximum and/or minimum grade truncations (eg cutting of high grades) and cut-off grades are usually Material and should be stated.</li> <li>Where aggregate intercepts incorporate short lengths of high grade results and longer lengths of low grade results, the procedure used for such aggregation should be stated and some typical examples of such aggregations should be shown in detail.</li> <li>The assumptions used for any reporting of metal equivalent values should be clearly stated.</li> </ul>	<b>No drilling is reported in this release.</b>																												
<b>Relations hip between mineralisation widths and intercept lengths</b>	<ul style="list-style-type: none"> <li>These relationships are particularly important in the reporting of Exploration Results.</li> <li>If the geometry of the mineralisation with respect to the drill hole angle is known, its nature should be reported.</li> <li>If it is not known and only the down hole lengths are reported, there should be a clear statement to this effect (eg 'down hole length, true width not known').</li> </ul>	<b>No drilling is reported in this release.</b>																												
<b>Diagrams</b>	<ul style="list-style-type: none"> <li>Appropriate maps and sections (with scales) and tabulations of intercepts should be included for any significant discovery being reported These should include, but not be limited to a plan view of drill hole collar locations and appropriate sectional views.</li> </ul>	<b>See attached Figures</b>																												
<b>Balanced reporting</b>	<ul style="list-style-type: none"> <li>Where comprehensive reporting of all Exploration Results is not practicable, representative reporting of both low and high grades and/or widths should be practiced to avoid misleading reporting of Exploration Results.</li> </ul>	<b>No drilling is reported in this release.</b>																												
<b>Other substantive exploration data</b>	<ul style="list-style-type: none"> <li>Other exploration data, if meaningful and material, should be reported including (but not limited to): geological observations; geophysical survey results; geochemical survey results; bulk samples – size and method of treatment; metallurgical test results; bulk density, groundwater, geotechnical and rock characteristics; potential deleterious or contaminating substances.</li> </ul>	<p><b>Seymour</b></p> <ul style="list-style-type: none"> <li>GT1 completed a fixed wing single sensor magnetic/radiometric/VLF airborne geophysical survey.</li> <li>Survey details, 1191 line-km, 75m line spacing, direction 90 degrees to cross cut pegmatite strike, 70m altitude.</li> <li>Final images have been received for Total Count Radiometric, Total Magnetics and VLF from MPX.</li> <li>Interpretation has been by Southern Geoscience</li> <li>Green Technology Metals conducted geological field investigations and mapping on the Seymour property throughout the second half of the 2023 field season. Efforts were focused on finding new pegmatite occurrences, while mapping the bedrock geology, minerals and structure, across the property. A crew of four collected 194 rock samples and mapped 196 outcrop stations, mainly in the north half of the Seymour property as well as the area immediately NW of the North Aubry deposit. No significant discoveries were made.</li> </ul>																												

Criteria	JORC Code explanation	Commentary
----------	-----------------------	------------

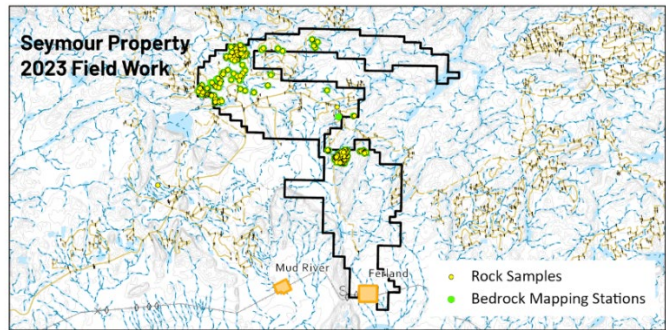

**Root**

- Further exploration was undertaken by GT1 in October 2021 over their Root Lake claims to better define prospective pegmatite bearing structures in the area.
- GT1 engaged Eagle Mapping Ltd of Suite C420 20178 – 96 Ave Langley British Columbia, Canada in September 2021 to undertake LIDAR over the Seymour, Wisa and Root prospect areas using a fixed wing Piper Navajo PA-31 aircraft. The resultant digital elevation and digital surface models are accurate to within +/-0.15m elevation and +/-0.30m horizontal direction and used as a high-quality base map in which to plan and action further exploration activities.
- GT1 also engaged Prospectair Geosurveys (of 15 chemin de l'Étang Gatineau, Québec) to undertake helicopter-borne magnetic geophysical survey on its Costello Lake, Allison Lake and Root Projects.
- The data was acquired via helicopter flying at 120km/hr on 50m line spacing with 21m mean terrain clearance in a north south flight direction on NAD83 / NUTM15 datum and projection.
- The raw data was processed and interpreted by South Geoscience Consulting Pty Ltd (SGC) of Perth Western Australia to generate several exploration targets to aid GT1 in their exploration targeting.
- SGC interpreted the geology and major structures based on local outcrop mapping and geophysical magnetic signatures of the underlying rocks. Litho-structural interpretation of this dataset at 1:20 000 scale.

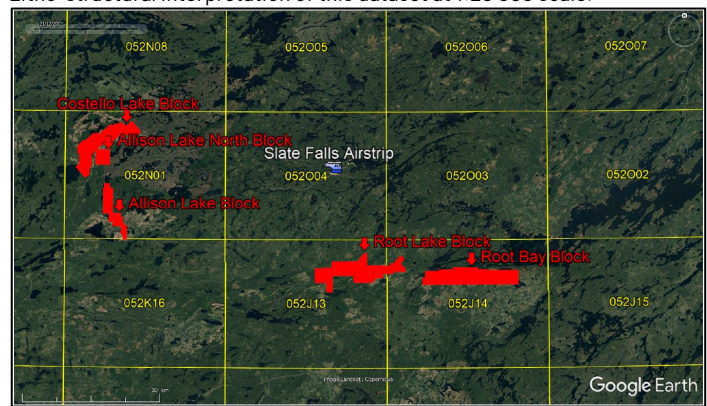
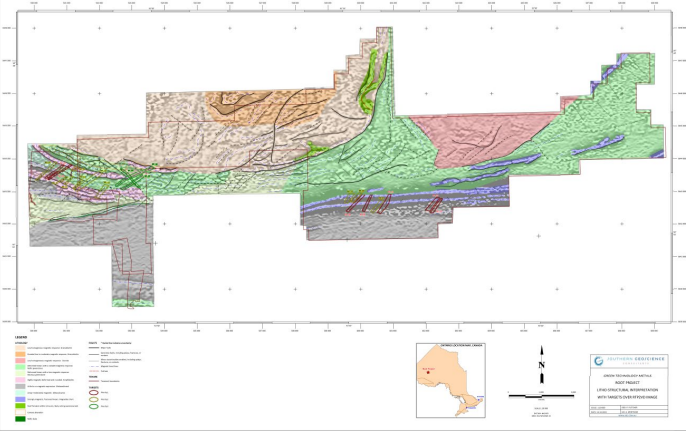

Figure 9 1 – Area covered by Aeromagnetic Surveys (Root, Root Bay and Allison)

- Numerous small zones of alteration or possible non-magnetic intrusions have been interpreted by SGC throughout the area. Discrete, local zones of demagnetisation are interpreted to define local faults, alteration zones, and subtle bends that may represent dilatational zones with potential to host mineralisation.

Criteria	JORC Code explanation	Commentary
		 <p data-bbox="792 695 1170 716">Figure 9 4 – SGC Geological Interpretation</p> <ul data-bbox="743 722 1479 1066" style="list-style-type: none"> <li>▪ Several pegmatite targets were identified based on structural interpretation of the magnetic response of basement formations.</li> <li>▪ Green Technology Metals conducted geological field investigations and mapping over the entire Root property from June through September 2023. 330 rock samples and 1539 outcrop stations were mapped. Vast areas of the property are covered with glacial and glaciofluvial till, therefore sample density is correlated to areas of bedrock exposure or topographic highs. Field crews located narrow (&lt;2m) spodumene-bearing pegmatites along the Root Bay east-west trend, but no new lithium occurrences were located on the remaining property. The abundant glacial overburden will force GT1 to use other techniques to discover additional spodumene-bearing pegmatites, primarily drilling and geophysics.</li> </ul> <p data-bbox="743 1094 1382 1115"><b>All relevant metallurgical testwork has been reported in this report.</b></p>
<p data-bbox="142 1152 217 1199"><b>Further work</b></p>	<ul data-bbox="269 1152 711 1352" style="list-style-type: none"> <li>▪ <i>The nature and scale of planned further work (eg tests for lateral extensions or depth extensions or large-scale step-out drilling).</i></li> <li>▪ <i>Diagrams clearly highlighting the areas of possible extensions, including the main geological interpretations and future drilling areas, provided this information is not commercially sensitive.</i></li> </ul>	<p data-bbox="781 1152 870 1173"><b>Seymour</b></p> <ul data-bbox="743 1180 1474 1331" style="list-style-type: none"> <li>▪ Further Geological field mapping of anomalies and associated pegmatites at Seymour and regional claims incorporating auger sampling to better test bedrock potential.</li> <li>▪ Further drill targeting around neighbouring tenements (Junior Lake) followed by diamond drilling over the next 24 months.</li> <li>▪ Continuation of detailed mining studies</li> </ul> <p data-bbox="781 1358 833 1379"><b>Root</b></p> <ul data-bbox="743 1386 1463 1606" style="list-style-type: none"> <li>▪ Further geological field mapping of anomalies and associated pegmatites at Root and regional claims</li> <li>▪ Sampling country rock to assist in LCT pegmatite vector analysis and target generation.</li> <li>▪ Infill drilling at the McCombe deposit to improve the deposits resource confidence.</li> <li>▪ Continuation of detailed mining studies</li> <li>▪ Further exploration and extension of the Root Bay pegmatites discovered to date.</li> </ul>