

ASX Announcement

28 March 2023

Goschen Project DFS Refresh delivers NPV of approximately A\$1.5 billion and 44% IRR

The Definitive Feasibility Study (DFS) Refresh demonstrates strong financial returns and high-margin pre-tax free cash flows of A\$270 million on average per year over initial ten years.¹

Highlights:

- VHM has revised its Goschen DFS completed in March 2022 and reported in the Goschen Prospectus dated 21 November 2022² (the Prospectus) to reflect work completed since the date of the Prospectus.
- The Goschen DFS Refresh indicates a high-value, low-cost operation for a fully integrated mining and treatment operation to produce zircon-titania Heavy Mineral Concentrate (HMC), Rare Earth Mineral Concentrate (REMC), and a Mixed Rare Earth Carbonate (MREC) with a nameplate process feed rate of 5 Million Tonnes Per Annum (Mtpa) for a foundation 20 year mine life.
- Robust average pre-tax free cash flow of A\$270 million per year over initial 10 years.¹
- Internal rate of return (IRR) of 44% (pre-tax).¹
- Net Present Value (NPV) of approximately A\$1.5 billion (pre-tax).¹
- Pay-back of 2.8 years from commencement of production.¹
- Initial operation considered by the DFS Refresh consumes 98.8 Mt of Ore Reserves and represents only 50% of identified Ore Reserves.
- The low operating cost of the Project and low capital intensity provides a compelling investment.
- Goschen presents an opportunity to add significant economic value to Australia's supply and trade position in the global critical rare earths markets.

VHM Limited (“VHM” or the “Company”) today announces the results of the Definitive Feasibility Study (DFS) Refresh for the Goschen Rare Earths and Mineral Sands Project (the Project) which confirm the Project as a potential world-class operation delivering robust economics.

Development of the Project will produce critical minerals of zircon-titania heavy mineral concentrate, a rare earth mineral concentrate (Phase 1), and a mixed rare earth carbonate

¹ For Phases 1 and 1A.

² As supplemented by the supplementary Prospectus dated 5 December 2022, and lodged with ASX on 5 January 2023.

(Phase 1A). Based on a forecast 20 year life of mine production schedule, the Project is expected to deliver compelling economics with a pre-tax NPV of approximately A\$1.5 billion and a 44% IRR and a pay-back of 2.8 years from commencement of production³.

The Project is at an advanced pre-production stage with Final Investment Decision (FID) for Phases 1 and 1A scheduled for H2 2023 upon receipt of regulatory approvals and permits.

VHM Managing Director, Graham Howard commented:

“The VHM team has been confident in the compelling economic scenario offered at Goschen and we are pleased to see the DFS Refresh verifying our confidence.

“The high-quality and relatively simple processing required to take rare earth and heavy minerals sands through production and into the market from Goschen underpins the excellent economics for the Project. This represents a highly significant step in Goschen’s evolution into a low-risk and high return project.

“With first production anticipated in 2025 and average pre-tax free cash flow of A\$270m per year expected for the initial 10 years. Further, the DFS Refresh informs an outstanding Net Present Value of A\$1.5 billion (pre-tax)³ over the life of mine. We look forward to delivering on this potential for shareholders.”

DFS Refresh Highlights

The DFS Refresh describes a well-defined and low-risk project across a number of categories including Mineral Resources, and Ore Reserves, mining methods, processing, land access, capex, life-of-mine, and operating costs.

The DFS is based on mining and processing a total of 98.8Mt Ore Reserves⁴, which is only a subset of the Company’s Ore Reserves of 198.7Mt⁵. The Goschen Project footprint and Ore Reserve subset of 98.8Mt sits within the freehold land envelope secured by purchase agreements.

Critical works undertaken during Q1 2023 which contribute to the outlook for the Project and prompted the DFS Refresh, include:

- Updates to capital and operating cost estimates based on 2023 market conditions and influences.
- Market study pricing updates (Q1 2023) for rare earths, zircon, and titania products.
- Completion of front-end engineering and design (FEED) optimisation studies for Process engineering, and design and optimisation for a mineral separation plant (MSP) and related process assets.
- Completion of metallurgical testwork and process design and engineering for the construction and commissioning of a hydromet circuit to upgrade the REMC to a MREC.

³ For Phases 1 and 1A.

⁴ Refer Appendix: JORC Ore Reserves, Table 2: Goschen DFS Ore Reserves subset of global Company Ore Reserves.

⁵ Refer Appendix: JORC Ore Reserves, Table 1: Company Ore Reserves.

- Completion of Hydrogeology and Hydrology studies for surface and sub-surface water management.
- Progressing Geotechnical studies in the areas of pit design, surface waste dump design, foundation engineering and tailings disposal and engineering.
- Progressing toward Environmental Statement decision, and subsequent Mining License grant.
- Tailings disposal and management.

Project Financials

The DFS Refresh demonstrates strong financial returns from the Project with sustained high-margin, pre-tax cash flows of A\$270 million per year for Phases 1 and 1A. This underpins the NPV of approximately A\$1.5 billion, together with its long life, robust cash margins and a pre-tax IRR of 44%,⁶ support its viability and provide a compelling commercial case for progressing from DFS to detailed engineering design and construction.

Estimated average EBITDA (Earnings Before Interest, Taxes, Depreciation, and Amortization) for integrated Phase 1 and Phase 1A for the initial 10 years of production is approximately A\$291 million per year.

Sensitivity analyses of $\pm 15\%$ for the Goschen Project economics have been carried out considering the forecast product prices, AUD/USD foreign exchange rates, mining, and processing OPEX and CAPEX costs.

Project Details

VHM proposes to develop a 20 year, 5Mtpa operation to mine and process zircon, titania, and rare earths mineral deposits in Victoria's premiere mineral sands province. The development will involve the mining and processing of heavy mineral sands containing valuable heavy minerals and rare earth minerals (REM) to be extracted from two areas, covering an area of approximately 1,534ha.

The proposed Project comprises three phases, with the DFS Refresh only relating to Phases 1 and 1A detailed below:

- Phase 1 - production of zircon- titania concentrate, and rare earths mineral concentrate (REMC) products.
- Phase 1A - construction of a hydrometallurgical (hydromet) circuit to convert the REMC into a mixed rare earths carbonate (MREC) product.
- Phase 2 - construction of a mineral separation plant (MSP) to further separate the zircon-titania concentrate into final zircon, ilmenite, HiTi rutile and leucoxene mineral products.

Phase 2 of the Project is not included in the FID process for H2 2023. Phase 2 will only proceed if prevailing market conditions, financial considerations, and sufficient additional funding support that decision at the time.

⁶ For Phases 1 and 1A.

The Project will bring direct and indirect downstream jobs to the Mallee Loddon Region and initial execution works are forecast to bring 200 construction jobs and 400 new, full-time jobs.

Investor Webcast and Conference Call

We encourage all shareholders to join Managing Director Graham Howard for a shareholder briefing at 11am (AEDT) on 31 March 2023.

Register for the session or request a replay: <https://vhmlimited.investorportal.com.au/investor-briefing/>

ASX LR 5.9.1 Requirements

The matters required by ASX LR 5.9.1 are set out as follows.

Material Assumptions and Outcomes

Table 1: 5Mtpa Goschen Project DFS Financial Metrics (Phase 1 and 1A)

5Mtpa Goschen Project DFS Financial Metrics (Phase 1 and 1A) ²				
Pre-tax NPV10 (A\$ m)		1,525		
Pre-tax IRR		44%		
Payback from commencement of production (years)		2.8		
Ore Reserve LoM (years)		20.5		
Average ore grade (THM)		4.0%		
Average strip ration (waste : ore)		2.6 : 1		
First 10 Years of Mine	Average Production (tpa)	REMC	9,428	
		MREC	8,568	
		Zircon-titania HMC	134,500	
	Average revenue per annum (A\$ m)		564	
	Average opex per annum (A\$ m)		273	
	Average EBITDA per annum (A\$ m)		291	
	Average unlevered, pre-tax FCF per annum (A\$ m)		270	
	Average revenue A\$/t ore		118	
	Average operating costs A\$/t ore		57	
	Payback period (years)		2.8	

Mining Schedule

The mining production schedule approximated to five year periods is shown in Table 2 below. This schedule incorporates only Proved and Probable material, there is no Inferred material within the ore mined.

Table 2: LoM mining schedule

Year:	0-5	6-10	11-15	16-21	LoM
Waste mining (Mt)	64.3	60.5	59.5	76.0	260.2
Ore mining (Mt)	24.7	25.1	25.0	23.9	98.8
Waste stockpile rehandle (Mt)	-	9.2	-	30.4	39.7
Total HM	4.9%	3.4%	3.3%	4.3%	4.0%
Zircon	29.1%	23.5%	19.3%	20.1%	23.5%
Rutile	11.3%	9.9%	9.0%	9.3%	10.0%
HGLX	9.4%	8.5%	8.0%	7.9%	8.5%
Ilmenite	25.0%	25.1%	25.2%	25.5%	25.2%
Monazite	4.2%	3.7%	3.2%	3.3%	3.7%
Xenotime	0.8%	0.7%	0.6%	0.6%	0.7%
Other HM	20.2%	28.6%	34.7%	33.3%	28.5%
SL	15.0%	16.7%	20.5%	16.0%	17.4%
Oversize	4.6%	3.6%	2.7%	3.0%	3.4%

Ore Reserve Estimate

Classification

The Ore Reserves as set out in Appendix D have been estimated in accordance with the requirements of the JORC Code based on Mineral Resources provided by VHM Limited as set out in Appendix B & C. Only Measured and Indicated Resources were used to inform the Ore Reserve and mine plan, any Inferred Resources present in the final pit designs were treated as waste.

Despite changes to the inputs used to generate the DFS Ore Reserves between March 2022 and March 2023, the DFS Ore Reserve is unchanged largely due to physical limitations relating to the approvals process and project footprint.

Mining Method and Assumptions

Standard truck/excavator open pit mining methods will be employed in a strip/block mining operation, with excavation, tailings deposition and rehabilitation being undertaken in a progressive sequence. The proposed mining sequence has been optimised to allow for complete extraction of ore, construction of in-pit tailings cells and deposition of homogenised tailings into each tailings cell without the need for an above-ground TSF. Mine waste will initially be stored on surface until such time as it can be used to construct the in-pit tailings cell bunds and to cover the deposited tailings to replicate pre-mining topography as closely as possible.

An overall wall angle of 30° was used for pit optimisations based on completed geotechnical studies. Pit designs used a batter angle of 40° in the uppermost bench (in the topsoil / clayey-sand material), with a 6 m wide berm created at the base of the clayey material or 10 m below surface, whichever produces the lower berm level (i.e. a maximum depth of 10 m). Beneath this berm, a single slope was designed to the pit floor; the slope angle used for this bench was either 34° in Area 1 East (overall pit depth generally ≤ 32 m) and 32° in Area 1 West and Area 3 (overall pit depth generally > 32 m).

The Resource model was regularised to have uniform cells of 25 m × 25 m × 1 m in size (from an initial minimum block size of 25 m x 6.25 m x 0.2 m). The process of regularising created a diluted model (with the equivalent of ~98% recovery and ~5% dilution) suitable for use in mine planning and Ore Reserve estimation with no further mining dilution or mining recovery applicable.

Processing Method and Assumptions

Processing of ore for the Ore Reserve Estimate was limited to Phase 1, consisting of a Mining Unit Plant (MUP), Feed Preparation Plant (FPP), Wet Concentrator Plant (WCP) and Rare Earth Flotation Circuit (REFC). Industry standard metallurgical processes and equipment are proposed for the Project.

A representative bulk sample taken from the mining area was used for testwork, this sample was processed through a pilot scale testwork laboratory.

An additional rare earth hydromet process was included in the financial analysis, the economic impact of this circuit is noticeably better than without, however has not been included in the pit optimisation, pit design or Ore Reserve estimation as they were not generated to a DFS level of confidence.

Cut-off Grades and Parameters

A single cut-off grade of a specific mineral or indicator was found to not accurately reflect the optimisation results due to the high number of variables within each block in the Resource model. As such a block value calculation was undertaken to classify each block as ore or waste, where if the expected revenue generated from the block is greater than the processing cost, the block was treated as ore, otherwise the block was treated as waste.

Inferred material was treated as waste during optimisations, designs and scheduling.

Estimation Methodology

Pit optimisations using GEOVIA Whittle mine planning software were prepared using input parameters, including OPEX, processing recoveries and product prices derived by the DFS Refresh. The optimisations were constrained by the water table and paddock boundaries/surface vegetation. Ore Reserves were calculated within pit designs based on the optimisation shells produced.

Material Modifying Factors

The DFS Refresh Reserve is constrained within an area over which an Environmental Effects Statement (EES) has been submitted to gain regulatory approval to commence mining operations.

The Project is located in an agricultural area of northern Victoria and is well serviced by road, rail, power, and water, with nearby communities able to provide labour and accommodation. Substantial consultation with the community and regulatory agencies in relation to the Goschen Project has commenced, involving consultation activities with identified key stakeholders.

Preliminary discussions with customers have indicated that 100% of products from Goschen will be subject to off take agreements.

Contents

1.	Introduction	9
2.	Proposed Operation.....	11
3.	EES and Permitting.....	16
4.	Exploration	19
5.	Mineralisation Styles.....	22
6.	Mineral Resource	22
7.	Hydrogeology	28
8.	Hydrology	29
9.	Geotechnical Engineering	30
10.	Ore Reserve Estimate	32
11.	Mining Strategy	34
12.	Metallurgical Testwork.....	38
13.	Process Engineering.....	40
14.	Tailings Management.....	45
15.	Infrastructure and Utilities.....	46
16.	Marketing	48
17.	Capital Cost Estimation	51
18.	Operating Cost Estimate	53
19.	Financial Evaluation.....	55
20.	Resource and Expansion Upside.....	60
21.	Legal	62
22.	Risks	65
23.	Future Works.....	66
24.	DFS Contributors	67
25.	Glossary of Terms.....	68

1. Introduction

VHM Limited (VHM or the Company) is proposing to develop the Goschen Mineral Sands and Rare Earths Project (Goschen, Goschen Project or the Project) in the Loddon Mallee Region of Victoria, approximately 35km south of Swan Hill in the Gannawarra Shire and 275km north of Melbourne (Figure 1). VHM was listed on the Australian Stock Exchange on 9 January 2023 after a successful capital raising via a Prospectus dated 21 November 2022.

In March 2022, the Company completed a Definitive Feasibility Study (DFS) for the development of Goschen. The DFS was the subject of an Independent Technical Assessment prepared by CSA Global Pty Ltd, which accompanied the Prospectus and the key findings of the DFS were disclosed in the Prospectus.

This document is an update on the DFS which, given the extent of the update, the Company has termed a DFS Refresh. VHM recognises three main project areas within the Company's tenements:

- The Goschen Rare Earths and Mineral Sands Project, the subject of the DFS and DFS Refresh.
- The Cannie and Nowie Rare Earth and Zircon Prospects.

The DFS completed in March 2022 defined an execution strategy for the development of a fully integrated mining and treatment operation with a nameplate process feed rate of 5 Million Tonnes Per Annum (Mtpa) with a 20 year mine life, to produce and market a range of mineral commodity products to national and international customers.

Since the release of the Prospectus dated 21 November 2022⁷, work has continued in the following key areas and has contributed to the DFS Refresh:

- Updates to capital and operating cost estimates based on 2023 market conditions and influences.
- Market study pricing updates (Q1 2023) for rare earths, zircon, and titania products.
- Completion of the Front-end Engineering and Design (FEED) optimisation studies, specifically process engineering and design, and optimisation for a Mineral Separation Plant (MSP), including Hot Acid Leach (HAL) and product loadout.
- Completion of metallurgical testwork and process design and engineering for the construction and commissioning of a hydromet circuit to upgrade the REMC to be produced in Phase 1, to a Mixed Rare Earth Carbonate (MREC).
- A continuation of work leading toward the completion and approval of an Environmental Effects Statement (EES).
- Hydrogeology and Hydrology studies for surface and sub-surface water management.
- Geotechnical studies in the areas of pit design, surface waste dump design, foundation engineering and tailings disposal and engineering.
- Tailings disposal and management.

The DFS Refresh demonstrates strong financial returns and sustained high-margin pre-tax nominal free cash flows (FCF) of \$270 million per year on average over the first ten years for Phase 1 and 1A. The Project's Net Present Value (NPV₁₀) of approximately \$1.5 billion (pre-tax nominal) together with its long life, robust cash margins and a pre-tax Internal Rate of Return (IRR) of 44% for Phase 1 and 1A, support its viability and provide a compelling commercial case for progressing from the DFS Refresh to detailed engineering design and construction. The initial 5Mtpa, 20 year operation considered by this DFS Refresh consumes only 50% of identified Ore Reserves.

⁷ As supplemented by the supplementary prospectus dated 5 December 2022, lodged with ASX on 5 January 2023.

The Capital Costs (capex) estimate for Phase 1 is A\$376 million (m), with an additional ancillary cost of \$106m for items such as; early mining, onboarding of personnel, land acquisition & approvals. Phase 1A Hydromet Circuit is an additional A\$124m⁸.

Upon formal operational commencement of Phase 1 in H1 2025, the total estimated annual Operating Costs (opex) for the Project are A\$148.6m.

With the additional formal operational commencement of Phase 1A expected in H2 2025, the total estimated annual opex estimate for the Project is A\$205.3m.

The DFS Refresh describes a low-risk project across a number of areas, including Mineral Resources, and Ore Reserves, mining methods, process residues, land access, capex and opex and Life-of-Mine (LoM). The proposed Project utilises industry standard technology and processes for mining the deposit.

Figure 1: Goschen Project location

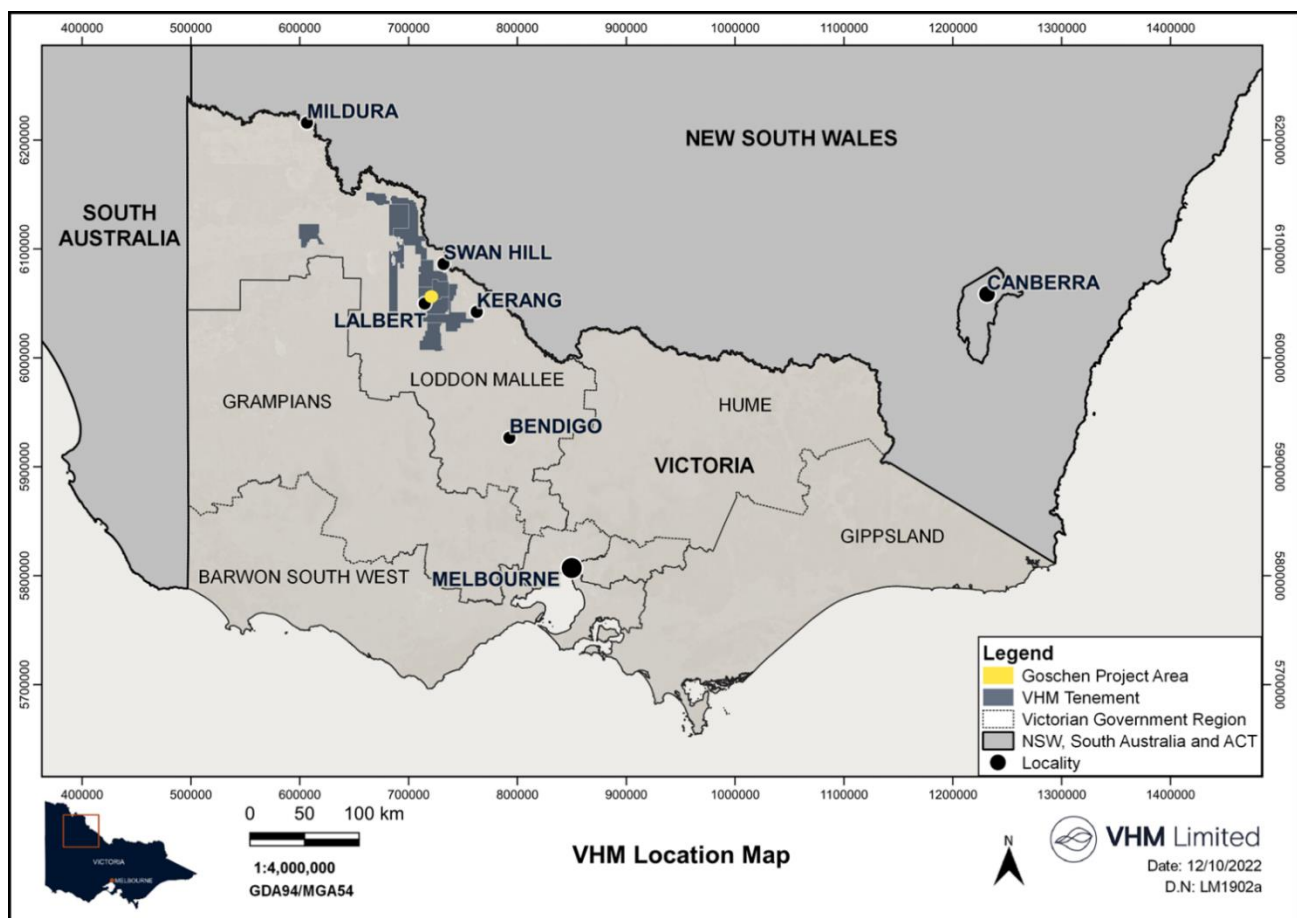

1.1 Key assumptions and risks

A detailed summary of key assumptions and risks in relation to the Company and its ability to progress the Goschen development project is set out in VHM Limited Prospectus dated November 2022.

By way of high-level summary for the purposes of the conclusions, forecasts and estimates provided in this document, the Company's ability to develop Goschen project as envisaged herein will depend on the successful realisation of the many factors customary for such developments, a number of which are noted below. Specifically, the progression of the Goschen Project will require:

⁸ AUD m real 2023

- Grant of requisite environmental, mining, and associated approvals to construct and operate the Goschen Project.
- Satisfactory arrangements for product offtake at volumes, prices, and such periods to provide adequate certainty to make the development decision.
- Availability of sufficient capital (equity and debt) to finance the project to at stage at which it is self-sustaining.
- Future capital and operating costs to be maintained at levels consistent with the assumptions contained herein, subject to anticipated growth tolerance levels.

2. Proposed Operation

VHM proposes to develop a 20 year, 5Mtpa operation to mine and process high-grade zircon, titania, and Rare Earth Minerals (REM). The development will involve the mining and processing of heavy mineral sands containing valuable heavy minerals and REM to be extracted from two areas; Area 1 and Area 3, collectively covering an area of approximately 1,534 hectares (ha).

Mineral Resource estimates and Ore Reserve estimates are largely constrained to Retention Lease (RL) 6806, with minor incursions into surrounding Company tenements (Figure 2).

Ore Reserves within Area 1 and Area 3 are 198.7 Million Tonnes (Mt.) The total Mineral Resource estimate, including areas not currently proposed for mining, is 629Mt. Mineral Resources and Ore Reserves have been estimated and reported in accordance with The Australasian Code for Reporting of Exploration Results, Mineral Resources and Ore Reserves (2012 edition) prepared by the Joint Ore Reserves Committee (JORC) - the JORC Code.

The DFS Refresh is based on mining and processing a total of 98.8Mt, which is only a subset of the Company's Ore Reserves of 198.7Mt. Based on current Ore Reserves, there are reasonable expectations for a minimum 40 year Project life. Further Mineral Resource estimates present the option to further extend the operation well beyond the initial establishment of the Project.

The Project is projected to create at least 200 construction jobs and 400 new full-time jobs. The workforce and operating supplies will be sourced from local rural centres wherever reasonably practicable.

Table 3: Project details

Key project details include:	
Mining	Mining is initially planned around a 5Mtpa process plant throughput. Mining will be by conventional open-cut methods utilising excavator, load, and truck haulage. Mining will commence in Area 1, then progress to Area 3. Mining will extend over approximately 1,534 ha of farming land and will occur only above the water table, eliminating the need to extract groundwater through in-pit dewatering.
Processing	<p>Phase 1: The mined ore will be processed on-site via a Mining Unit Plant (MUP) and Wet Concentrator Plant (WCP) to recover Heavy Mineral Concentrate (HMC). The HMC will undergo further processing to produce a zircon–titania concentrate and an REMC.</p> <p>Phase 1A: The REMC will be processed via a hydromet circuit producing MREC.</p> <p>Phase 2: Consists of an MSP and, subject to prevailing market circumstances, a HAL and chromium-removal circuit will produce additional products, such as premium zircon, zircon concentrate, high titania (HiTi) rutile, leucoxene, and low-chromium ilmenite.</p> <p>Tailings from the various mineral processes and mining overburden/waste will be homogenised and placed back into the mined-out areas.</p>
Rehabilitation	Back-filling of the mined-out areas will occur in a staged manner to allow overburden and topsoil placement in a profile that reinstates the original soil structure. This will return the land to a condition suitable for agriculture within three years of mining.
Water	<p>Water will be required for construction earthworks, processing, dust suppression and rehabilitation. Up to 4.5 Gigalitres Per Annum (Gl/a) of water will be needed for the start-up (12 months), reduced to 3.2Gl/a thereafter. Water will be sourced from Kangaroo Lake and purchased from Goulburn–Murray Water through the open water market. Water will be delivered to site via a 38-kilometre underground pipeline to be constructed beneath existing local road easements (Refer to section 3.3.1).</p> <p>The current capacity of the Kangaroo Lake water supply is more than 500Gl/a. The Project’s water requirements will not place any constraints on availability for existing or future agricultural activities.</p>
Power	Electrical power requirements for mining and processing will be initially met on-site from dual-fuel (i.e. diesel and gas) generators, with the intention to connect to regional renewable energy grid-based power supply as soon as practicable after the commissioning of the Kerang Link, in 2025/26.
Transport	Once packaged, products will be loaded into 20-foot sealed sea containers and transported to the port via existing road and rail facilities for customer shipment.

2.1 VHM tenements

VHM Limited is the registered holder of RL 6806 and Exploration Licence (EL) 6419, which cover the Goschen Project. Other ELs held by VHM are EL6666, EL6664 and EL6769. The total tenements extend over an area of approximately 2,860km².

VHM’s granted tenure is summarised in Table 4 and depicted in Figure 2.

Table 4: VHM Limited tenure

License Number	Location	Registered Holder	Project	Status	Area (km ²)	Grant date	Expiry Date
RL6806	North West Victoria	VHM Ltd	Goschen	Current	311	10/01/2020	9/01/2027
EL 6419	North West Victoria	VHM Ltd	Cannie	Current	443	18/05/2018	17/05/2023
EL 6664	North West Victoria	VHM Ltd	Cannie	Current	618	18/06/2018	17/06/2023
EL 6666	North West Victoria	VHM Ltd	Nowie	Current	447	18/06/2018	17/06/2023
EL 6769	North West Victoria	VHM Ltd	Exploration	Current	1041	27/08/2018	26/08/2023
Total Area					2,860		

Figure 2: Location of VHM tenements.

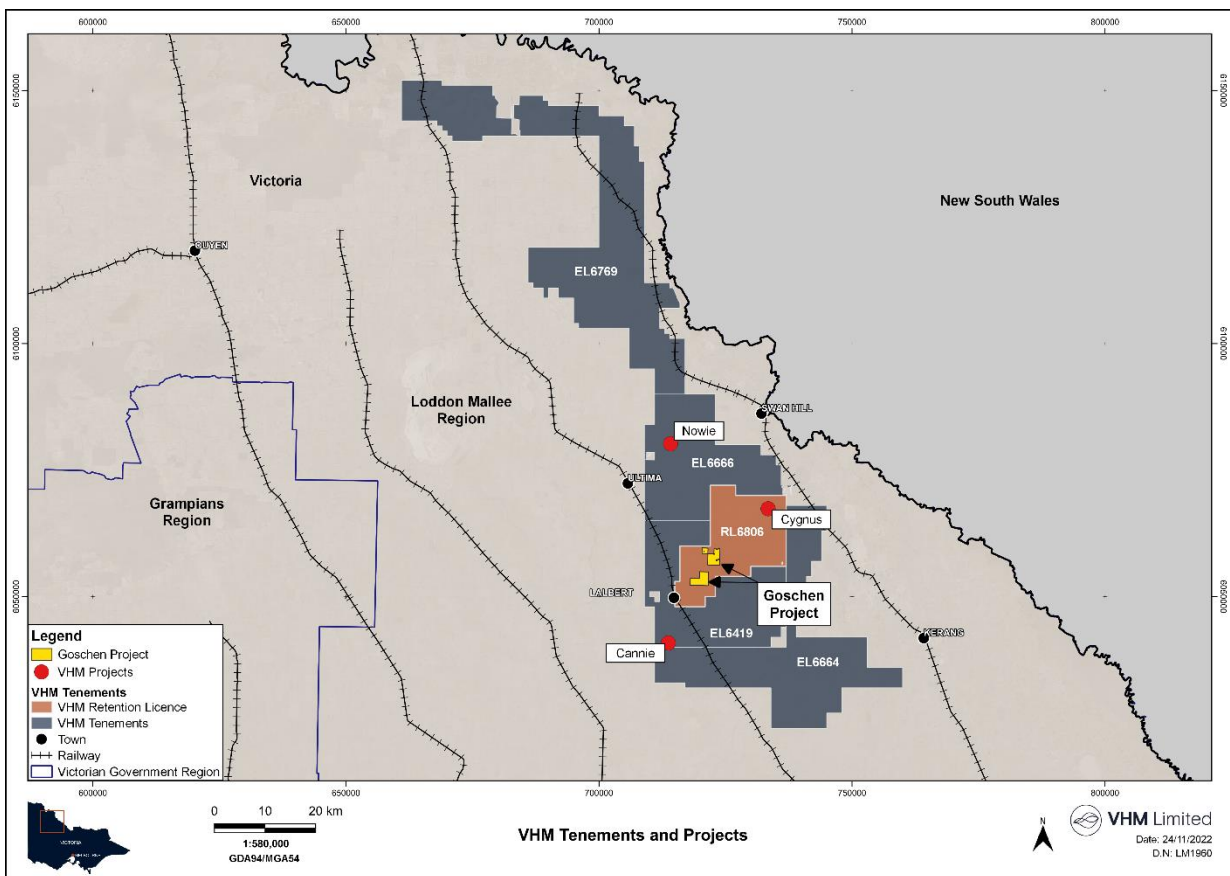

2.2 Transport and logistics

Once processed and packaged, final products destined for overseas customers will be transferred via road, 18km to the Ultima intermodal terminal, operated by Qube Logistics and then by rail to the Port of Melbourne for shipment (Figure 3).

The logistics study identified supply chain options and costs for:

- Product packaging, transportation, and interim storage. This will be in standard 20 foot shipping containers.
- Packaging and sealing of sea containers will be on site.
- Melbourne is the preferred port for export of products, and import of materials and supplies.

VHM is currently in negotiations with Qube Logistics to progress an MOU for provision of all product transport services, however there is no guarantee that any agreement will be reached.

Figure 3: Transport route for Goschen products to Ultima Intermodal

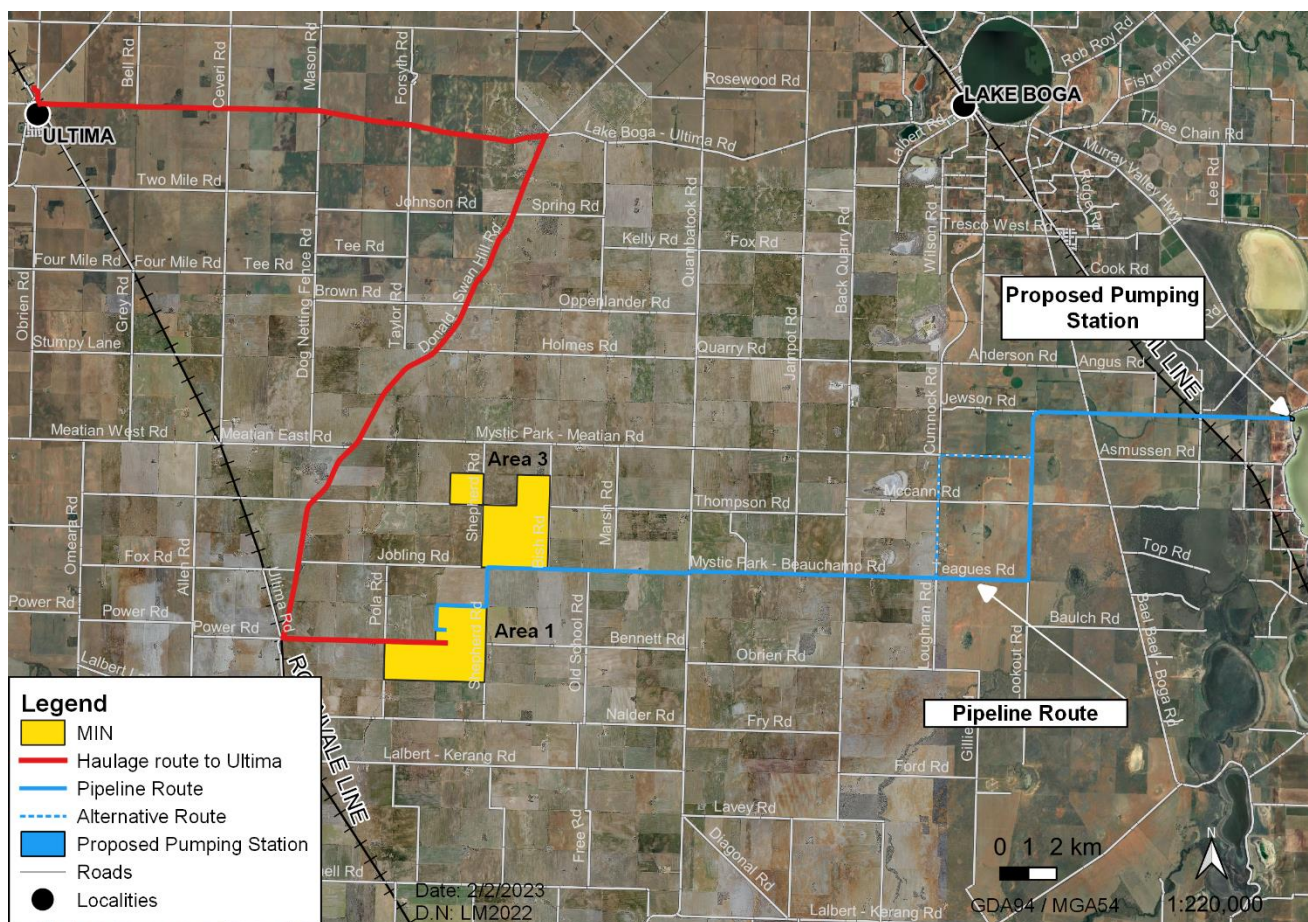

2.3 Development strategy

The development of the Goschen Project is planned to occur in three phases with the immediate focus being on Phase 1 and 1A;

- **Phase 1** consists of an MUP, Feed Preparation Plant (FPP), WCP and a Rare Earth Mineral Flotation Circuit (REMFC) producing REMC and zircon-titania concentrate.

- **Phase 1A** introduces a hydromet circuit to further upgrade the REMC into higher value MREC.
- **Phase 2** will consist of an additional MSP to produce final mineral sand products, which include ilmenite, zircon, leucoxene, and HiTi/rutile. Phase 2 will only proceed subject to prevailing market conditions, financial considerations and sufficient additional funding being secured and is not the subject of the Final Investment Decision (FID) for Phase 1 and 1A targeted for H2 2023.

Table 5: Development strategy

Development Phase	Development Scope	Development Criteria	Development Location
Phase 1 Concentrator	Goschen Project - Base Case, MUP, FPP, WCP, REMFC	Foundation Project	Goschen Locality
Phase 1A Hydromet Circuit	Goschen Project - Expanded Case (addition of Hydromet Circuit)	Expansion Project	Goschen Locality
Phase 2 MSP	Goschen Project - Final Case (addition of MSP)	Expansion Project	Goschen Locality

2.3.1 Proposed development schedule

A project schedule has been developed. A high-level summary is shown in Figure 4. This schedule anticipates the execution of the Project over approximately 42 months. This schedule depends on the following assumptions:

- Permitting has been acquired and is in place.
- Funding has been obtained and is released for the commencement of work.
- The required resources are available.

Figure 4: Proposed Project development schedule

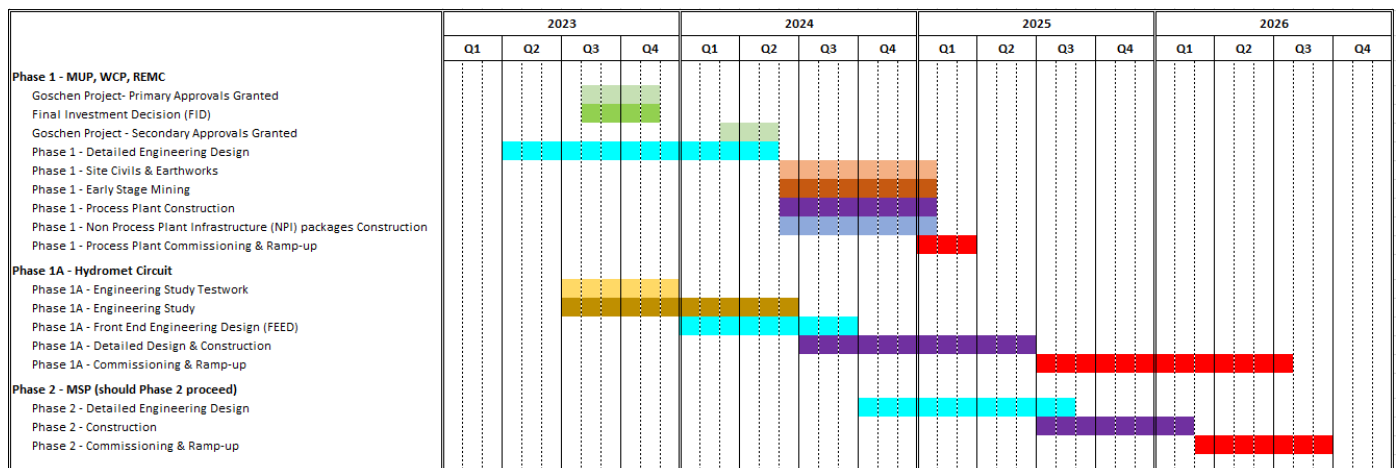

3. EES and Permitting

3.1 EES

The *Environment Effects Act 1978* (Victoria) (EE Act) establishes a legislative framework to assess the environmental effects of proposed works that could significantly affect the environment.

The EES process is required to assess impacts on matters of national environmental significance through a bilateral agreement between the Commonwealth and the State of Victoria. Provided an EES has been prepared in accordance with the bilateral agreement, there would be no requirement for separate assessment by the Commonwealth.

The EE Act enables the Victorian Minister for Planning (Minister) to decide whether a proponent is required to prepare an EES. In October 2018, the Minister determined that an EES was required for the Project. The Minister subsequently issued EES Scoping Requirements, which set out the matters which must be addressed in the Goschen EES, and includes potentially significant effects on:

- Native vegetation and associated biodiversity values, including listed threatened species
- Surface water and groundwater and protected beneficial uses
- Existing land uses, amenity, and landscape values
- Aboriginal cultural heritage values

The Project was also referred to the Commonwealth and categorised as a 'controlled action' requiring assessment and approval.

3.2 Results of environmental assessment

The Goschen EES considers design approach, construction methodology, operation, decommissioning, and the specific potential environmental impacts of each of the components of the Project.

Key findings of the environmental studies completed to date are:

- Approximately 97% of the Project's mine site area has already been cleared for agriculture; therefore, minimal native vegetation disturbance will occur.
- Remnant vegetation primarily occurs along road reserves and in small patches and includes the following Ecological Vegetation Classes:
 - Woorinen Mallee (vulnerable)
 - Plains Savannah (endangered)
 - Ridged Plains Mallee (endangered)
 - Riverine Chenopod Woodland (depleted)
- There are no surface water drainage lines, channels, or wetlands within the Project area.
- The depths to groundwater range from approximately 20m to 50m. Groundwater quality ranges from brackish to saline.
- The proposed mine pits will not intersect the existing water table.
- Assessment of background gamma radiation indicates that levels are within the normal background range seen throughout Australia.
- There are no native title claims over the Project area and no known registered historical or cultural heritage sites. A field survey identified a low risk of potential cultural heritage impacts, with no artefacts found.
- Baseline air quality monitoring has been completed to Environment Protection Authority (EPA) requirements and shows frequent exceedances, mostly in summer and largely attributed to agricultural cropping, dry periods, and bushfires.

- Respirable crystalline silica and arsenic concentrations were below the applicable criteria.
- A preliminary visual impact assessment indicates that the Project will have minimal visual impact on the surrounding landscape.

3.3 Approvals

Several state and Commonwealth environmental referrals have been completed, with approvals expected progressively over 2023–2024. The major environmental approvals process involves assessment under the Environment Protection Biodiversity Conservation Act 1999 (Cth) (EPBC Act) and the EE Act.

Since the scoping requirements were released, the Project has been refined to provide clearer definition of the on-site operations and to avoid/minimise a range of potential environmental and social impacts. In October 2022, a variation to the original EPBC referral was submitted to the Department of Climate Change, Energy, the Environment and Water. The variation related to two key changes; reduction of the proposed mining area from 8,300 ha to 1,534 ha and the addition of approximately 28.6ha of initial disturbance required for the construction of a pump station adjacent to Kangaroo Lake, together with a water supply pipeline to the mine site. The variation was accepted on 30 January 2023.

Site surveys and environmental assessments required under the EES Scoping Requirements were completed in 2022. The draft studies have been presented and reviewed by key regulatory officers in the Technical Reference Group (TRG), chaired and convened by the Department of Transport and Planning (DTP) - Impact Assessment Unit. Comments from the TRG have been reviewed and where appropriate, incorporated by the respective specialists into each of the impact assessments. Final technical reports, supporting management plans and the EES chapters are to be assessed by the DTP for adequacy against the scoping requirements to allow the public exhibition of the EES in the first half of 2023.

The refinements to the Project have meant that several material impacts have been eliminated or minimised. These include:

- All mining will occur above the existing water table.
- The proposed mining will avoid all significant remnant patches of native vegetation in agricultural land, excluding roadsides.
- A reduction in atmospheric and noise emissions within the mine footprint.
- Avoidance of any culturally sensitive sites within the mine footprint - a complex assessment is not required under the Victorian Aboriginal Heritage Act 2006.
- Elimination of the need for a Tailings Storage Facility (TSF) – tailings and process waste will be homogenised and placed back into the mine's open pit.

A mining licence over the Project area will be sought concurrently with the EES approvals process.

3.3.1 Secondary consents

The principal approval once the Victorian Minister for Planning has recommended the project can proceed based on the EES is the Work Plan (under the Mineral Resources (Sustainable Development) Act 1990). Submission of the final Work Plan to Earth Resources Regulation can only occur after the EES process is completed.

Other secondary consents to be sought after EES, including various permits and licenses to be sought to allow construction and operation of the Goschen Project include the following:

- Works Licence from Goulburn Murray Water (GMW) for the construction of water pipeline from Kangaroo Lake to the mine site
- Works (Operate) Licence from GMW for water pipeline
- Water Licence from GMW for necessary water allocation
- Works on a Waterway Permit from Catchment Management Authority for various water crossings
- Water licence from GWM for in-pit water management
- Permit from EPA for deposition of tailings in-pit
- Approval by the relevant authority of the following management plans:
 - Radiation Management Plan (as is customary for all mineral sands mining operations)
 - Native Vegetation Off-set Management Plan
 - Traffic Management Plan

3.4 Next steps in EES process

The EES, together with the draft Work Plan, draft Planning Scheme Amendment (PSA) and the EPA Development Licence application, will be available for public comment for 30 business days. After the exhibition period, a joint Inquiry and Advisory Committee (IAC) appointed by the Ministry will hold a Directions Hearing, where the necessary arrangements and timetable for the public hearing will be established.

The IAC will review the public submissions, the EES, the draft PSA, and the EPA Development Licence application, after which it will consider the environmental effects of the Project in accordance with the Terms of Reference issued by the Minister.

The IAC will provide a report to the Minister who will use this to make an assessment of the Project's environmental effects. The Minister will make recommendations about whether the environmental effects of the Project are acceptable and communicate these to those responsible for issuing environmental approvals for the Project.

3.5 Land use

An assessment of land use impacts concluded that, on balance, the Project is consistent with and is supported by State and local planning policies. These policies support the appropriate use of natural resources and the associated economic and social benefits.

The assessment found that the Project is consistent with the broader region's long-term vision for growth and land use planning. Provided all amenity management and mitigation controls identified in the EES are implemented and monitored, the Project will not result in unacceptable or long-term land use planning impacts.

3.6 Cultural and heritage

No Aboriginal cultural heritage places have been identified within the development area as a result of the preliminary desktop assessment and subsequent field archaeological survey. The field survey also concluded a very low likelihood of subsurface Aboriginal cultural heritage.

The entirety of the Project area has undertaken thorough ploughing activities with the removal of the lower calcareous layer included and exposed limestone/ironstone nodules at the surface. It is expected that this ploughing activity would have exposed any archaeological artifacts had they been present.

As the Project progresses into the construction and operation phases, there is always the potential that ground disturbance may reveal previously unidentified and unregistered Aboriginal cultural

heritage, resulting in loss of heritage values. As a mitigation measure, the Company intends to develop an Aboriginal Cultural Heritage Management Plan to document potential impacts, controls, processes, and reporting measures to manage any impacts on Cultural Heritage.

3.7 Community engagement and social licence

VHM understands and acknowledges it is critical to seek and maintain a social licence through all Project stages. It maintains an active presence in the community during the current approval process and is actively engaging with all landowners directly and indirectly. An updated consultation program is in place to maintain constructive and positive community engagement.

VHM is implementing a Community and Stakeholder Engagement Plan, which demonstrates its commitment to establishing long-term, beneficial stakeholder and community relationships.

VHM has established working relationships with local, state, and federal government agencies, first nation peoples, the rural water authority, landholders, and the catchment management authority. All are aware of the Project. VHM is consulting with local Aboriginal Australian communities and the Traditional Owners - the Wamba Wamba and Barapa Barapa peoples - and will continue to engage relevant stakeholders and the community.

A community benefit program is under development that consists of community sponsorship, grants, training, scholarships, local jobs, and procurement. It will be informed through community and landowner consultations to ensure it is tailored to community needs and aspirations.

A Neighbourhood Agreement proposal is currently being presented to landowners who reside within 3.5 kilometres from the proposed mine site boundary. This proposal acknowledges the change in amenity to local landowners once mining activity commences. The proposal is expected to consist of an immediate sign on payment followed an annual payment that commences on construction, which will continue (CPI adjusted) until all mining activity ceases. There is no guarantee that this agreement, or any agreement with the landowners, will eventuate.

VHM is progressing Memorandums of Understanding (MOUs) with Gannawarra Shire Council and the Swan Hill Rural City Council. The MOUs outline how the Shires and VHM are committed to working collaboratively to identify and progress opportunities that will deliver social and economic development benefits for the region.

4. Exploration

4.1 Exploration history

The Goschen area has seen substantial exploration, with multiple owners and joint ventures. From the 1970s to 2009, exploration was undertaken by CRA Exploration (CRA), Austiex, RGC Exploration Pty Ltd (RGC), RZM, Warren Jay Holdings Pty Ltd, Providence Gold and Minerals Pty Ltd (Providence), Basin Minerals NL (Basin Minerals) and Iluka Resources Ltd (Iluka).

Within EL6664, six priority airborne magnetic features were identified using proprietary TargetMap™ software. Drilling by Iluka in 2008-2009 intersected the 'Quarry East Strand'; however, it contained high levels of trash Heavy Minerals (HM) and relatively low valuable heavy minerals. This strand extends into the Company's tenements and is considered worthy of follow-up.

BHP explored EL1889 between 1987 and 1990, focusing on rutile mineralisation; however, only low concentrations of Total Heavy Minerals (THM) were reported. The central portions of EL6769 have been identified as prospective and VHM is planning follow-up work.

MBT, Providence, RGC and Iluka explored within EL6419 between 1990 and 2008. During this time, MBT completed three drilling programs, then relinquished the tenement due to a lack of success.

Despite the extent of previous exploration, no historical data has been used in the Company's Mineral Resource estimates.

4.2 VHM drilling

Four areas were selected for detailed evaluation:

- Area 1 and Area 1 West
- Area 2 West
- Area 3
- Area 4

These are collectively termed 'Resource Areas' and the DFS considers the development of Areas 1 and 3, whereas the other resources may support expansion opportunities in the future.

Reverse Circulation and Aircore (AC) drilling, plus some sonic drilling, have been used to evaluate the deposits. AC is considered a standard mineral sands industry drilling technique whereby the sample is collected at the drill bit face and returned inside an inner tube. All holes were drilled vertically, with the majority of samples taken at 1m downhole intervals.

Drill samples were split to 1.2 – 2.5kg using a rotary splitter. All samples were logged for lithology, colour, grain size, grain size sorting, hardness, sample condition, washability, estimated THM percentage, estimated Slimes (SL) percentage and any other relevant features. Samples were dispatched to either Diamantina Laboratories (Diamantina) or ALS Laboratories (ALS) for assay.

Downhole gamma logging was undertaken on many AC holes. Gamma logs provide quantitative data about the in situ radioactive elements in the drill sample walls. The gamma logging was used in the interpretation of geological units and grade domains during resource estimation.

4.3 Sample analysis

4.3.1 Diamantina Laboratories

Drill hole assay sample splits were submitted to Diamantina, where they were oven dried, and then split down to approximately 100g sub-splits. One sub-split was wet screened through a vibrating deck screen, with about half the total number of samples (about 10,000) screened at 2mm/38µm, and the balance at 1mm/20µm. The intermediate fraction is termed the sand (SAND) fraction which contains the recoverable HM, whilst the mass retained by the upper, coarser screen is termed oversize (OS) and rejected. The material passing through the lower screen was lost to wastewater as slimes (SL) with the weight of SL calculated by difference.

The SAND fractions were individually dried and weighed before being submitted to Heavy Liquid Separation (HLS) using tetrabromoethane. The HLS sinks were washed with acetone, dried, and weighed, and the floats were discarded. Every 25th sample was submitted to the same process as a laboratory repeat, whilst every 40th sample was subjected to the same process as an internal laboratory standard for quality assurance/quality control.

4.3.2 ALS Laboratories

4.3.2.1 Heavy liquid separation

After oven drying, samples were split down to 50g sub-splits. These were soaked for 24 hours in 1% Tetrasodium Pyrophosphate (TSPP) (a dispersing agent used to help disaggregate clays) before wet screening at 2mm/20µm. OS and SAND were individually captured, dried, and weighed, whilst SL was lost to wastewater. The SAND fraction was then mechanically agitated in 1% TSPP for 5 minutes

and then re-screened for separation of the THM fraction by HLS. The samples were centrifuged during HLS.

As with Diamantina, every 25th sample was used as a laboratory repeat and every 40th sample as a laboratory standard.

4.3.2.2 Mineral assemblage determination

Mineral assemblage (MA) composites were prepared for Area 1 and Area 3. Quantitative Evaluation of Minerals by Scanning Electron Microscopy (QEMSCAN) and X-ray fluorescence (XRF) were used to determine a wide suite of mineral species, viz: zircon, rutile, leucosene, ilmenite, xenotime, monazite, garnet, tourmaline, sulphides, chromite, and quartz. QEMSCAN was used to determine mineralogy and XRF for elemental assays. QEMSCAN required the samples to be screened into +/- 150µm screen fractions before sample compositing to give a quantitative understanding of the elemental composition and mineralogical assemblage.

Minerals with similar properties were grouped together to form general groupings such as magnetic (mag) and non-magnetic (non-mag). The grouping supported simplicity and transparency when including the MA composite results in the Mineral Resource models.

4.4 Analysis of results

The potential for the introduction of bias and inconsistency between different generations of drilling by using different screening and assay methods is important. It has been evaluated in some detail, as these differences might influence the resource estimates.

Assay sample residues from the initial drilling campaigns submitted to Diamantina were screened to recover a 2mm/38µm SAND fraction. Subsequently, samples were screened to 1mm/20µm, the same as that eventually used for VHM's drilling samples. Sample residues submitted to ALS were screened to recover a 1mm/20µm SAND fraction.

In January 2019, a comparative analysis was prepared, which focussed on the high-grade area within Area 1. For the comparison, 158 MA composites were prepared using the two screening sizes. An independent assessment concluded that the loss of either the -38µm or -20µm fractions during the screening/assay of the original samples was not a consideration in the resource estimates. However, it was found that the smaller screen size assays yielded higher THM values. It was concluded that the assay data generated from the -1mm/+20µm screened samples were appropriate for use in Mineral Resource estimate.

4.5 Metallurgical bulk sample collection

The two composite types were interwoven throughout the Measured Resource area. However, during Mineral Resource estimate, this was mitigated by removing the +38µm MA composites, so only the +20µm composites influenced the measured Mineral Resource estimate metallurgical bulk sample collection.

Following the initial metallurgical characterisation testwork using individual 1m drilling samples, further testwork was conducted using a 1.8t bulk composite made up of selected AC drill samples from Area 3. The sample comprised bulk rejects (each 5–7kg) left after the primary assay split had been taken from the original 1m drilling samples. A second round of testing was undertaken using a composite sample of approximately 9.1t from selected AC and sonic core drill intervals from Areas 1 and 2.

Two more bulk samples were subsequently collected from Areas 1 and 3. Seven-inch diameter sonic drilling cores were used to generate a sample to recover REM to an REMC to enable testwork, and product processing and evaluation.

The drill hole locations were designed to provide confidence that the samples represented the mineralisation to be mined over the first two years of operations. Internal waste was included within

the mineralised composites from each hole to reflect actual mining practice. The holes were drilled within 5m of existing AC holes to provide the most accurate comparative geological, assay and MA data possible and to ensure accurate correlation to the current resource model. Additional geotechnical and density data were also collected as part of the program.

5. Mineralisation Styles

Two distinct styles of deposits occur: sheets and strandlines. The sheet-style deposits contain relatively fine-grained HM (sub-100 micrometre (μm) with some in the 20–40 μm range). The sheet-like deposits are also known as Wimmera-style (WIM-style) deposits. Two smaller and less significant mineralised zones have been identified closer to the surface that are laterally discontinuous across the Project area. These two zones are heavily affected by iron oxide induration, which grinds up during drilling and reports to heavy media separation sinks as fine HM.

Although most WIM-style deposits generally have ultra-fine heavy mineral grains, the strandline deposits can be variable and contain some coarse-grained HM. These are also known as beach placer deposits. The strandline deposits are formed in high-energy surf zone settings, and commonly attain strike lengths of 5–40km. Sheet deposits occur in nearby shallow marine settings as irregular accumulations, in lower shore and inner shelf environments.

Strandline deposits are the target of much mineral sand exploration as they are well understood, higher grade, and coarser grained than contemporary sheet-style deposits, with demonstrated economic viability. Globally, numerous mineral sand mining operations are based on strandline-type deposits.

In the south-eastern part of the Murray Basin, where the Project is located, the littoral marine sand units of Loxton Sand have been variously eroded and few strandline-style deposits remain. Deposits associated with lower energy depositional environments such as sheet-style deposits and shore parallel, deeper water; intermediate-grain-sized deposits occur in finer grained sediments within the Loxton Sands. These deposits tend to be less well defined than coarse-grained strandline style deposits; however, they represent large-tonnage and low-grade accumulations of HM.

VHM's most recent resource definition drilling has defined a series of higher grade, sub-horizontal, sheet-like deposits (typically >5%THM based on Area 1 and Area 3 metallurgical testwork programs), which are surrounded by a series of halo (>0.5% THM) mineralised zones. The halo mineralisation contains potentially economic concentrations of zircon, titanium minerals and REM.

Contemporaneous strandline deposits are also hosted within the Loxton Sand. These are typically 100 m to 600 m wide and strike in a north-north-west direction. Some of these systems have been defined over strike lengths of 30km.

6. Mineral Resource

Drilling before VHM acquired the project identified several areas of interest. Subsequent work in 2020 and 2021 confirmed Area 1 and Area 3 as the most prospective and these became the focus of development and Ore Reserve studies. The Mineral Resource estimates were prepared by independent consultants IHC Robins, Right Solutions Australia and the Company and have not been updated as a result of the DFS Refresh. Future work in developing a maiden Mineral Resource estimate for Area 2 East is planned to commence in H1 2023. The Area 2 East Mineral Resource estimate will increase the Company's Mineral Resource inventory supporting future studies. Following the completion of the metallurgical testwork based on the 2022 bulk sample program, the Company will re-evaluate and revisit the Area 1 and Area 3 Mineral Resource estimate.

6.1 Mineral Resource estimation database

The Mineral Resource estimates and other studies prepared by VHM do not include any historical exploration data.

The Mineral Resource estimate database comprises of:

- Drill hole collars, lithology, survey data, assays, mineral composites, and down-hole geophysical gamma logging results.
- Microsoft Excel files with field duplicates and standard reference material.
- Microsoft Excel files from Diamantina with raw and calculated assay data and from ALS with QEMSCAN and XRF data.
- VHM files containing the downhole geophysical gamma logging data.
- Raw analysis data files from the laboratories, including cross-checks.
- A digital terrain model generated using data from a Light Detection and Ranging survey carried out in 2018.

Within Area 1, the drilling database comprised a total of 10,736 assays. During 2017 and 2018, 4,388 samples were assayed for THM. SL and oversize were separated from the SAND fraction by screening at 2mm and 38µm. Between January 2018 and January 2019, a further 4,847 samples were screened to recover a SAND fraction between 1mm and 20µm.

6.2 Area 1 Mineral Resource estimate

The Area 1 deposit is a multiple, stacked, sheet-like accumulation of HM hosted by very fine-grained sand that was deposited in what is interpreted to have been a relatively deep, low-energy marine environment.

6.2.1 Geological interpretation

Geological boundaries were defined by a 0.8% THM cut-off grade that was considered more suitable for domaining due to the significant amount of 'background' mineralisation grading about 0.5% THM. Strings were digitised and three-dimensional shapes were generated to define the mineralised domains.

6.2.1.1 Area 1 East

Area 1 East is located east of the Cannie Fault and comprises six geologically recognisable domains. The most significant of these are Domains 2 and 3, both of which have high THM grades, which are relatively continuous along strike. Domains 2 and 3 occur together as sheet-like mineralisation, separated in places by a discontinuous low-grade waste zone (Domain 1).

An envelope was created to encapsulate the samples used to create the metallurgical bulk sample (Metallurgical Domain), and the AC samples around them. The envelope included parts of the Mineral Resources of Area 1 East. The Mineral Resource estimates outside the area of influence of the metallurgical testwork was informed by interpolation of grades.

6.2.1.2 Area 1 West

Area 1 West is located west of the Cannie Fault and comprises of five domains. Domain 2 has high THM, with relatively good continuity along strike. Grades vary across strike, generally increasing to the west. Domain 3 has high THM grades with reasonable continuity along strike and relatively variable grades. Both Domains 2 and 3 occur together as sheet-like deposits, separated in places by a discontinuous low-grade waste zone (Domain 1).

Figure 5 is a typical section through Area 1 and shows the domains and downhole gamma responses.

Figure 5: Typical section through Area 1 showing the domains and downhole gamma responses

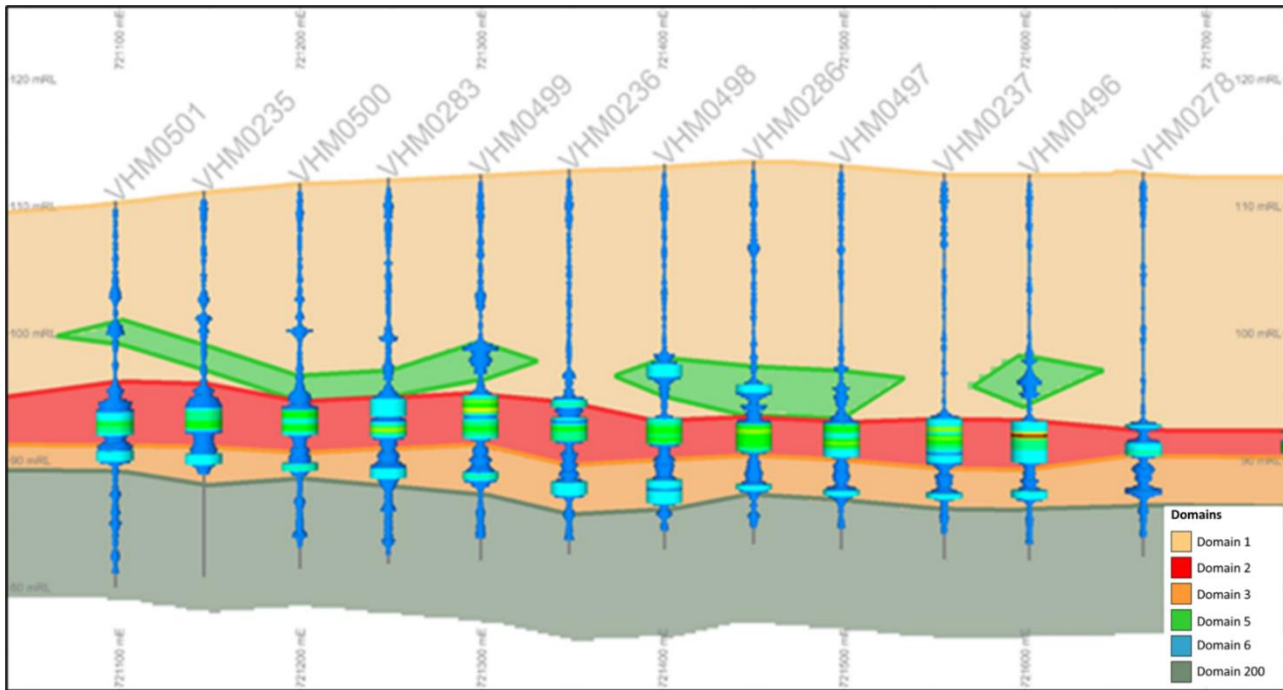

6.2.2 Estimation methodology

Boundary strings were digitised and snapped to the corresponding downhole mineralisation intervals and aligned with the downhole geophysical data. Intervals of relatively contiguous low grade were defined as 'waste.' Domains were assigned hard boundaries and did not share sample data.

The Mineral Resources Statement (Table 6) shows Area 1 East tonnes and grades above a 1% THM cut-off. Area 1 East, Domain 2 and 3 estimates used the samples collected from the -1mm/+20µm SAND fraction and Domain 5 (a low-grade zone above the main mineralised domains), assays from samples screened to -2mm/+38µm SAND.

Area 1 East resource modelling indicates that the average THM grade for the -1mm +20µm SAND samples used to make up the metallurgical composite is significantly higher than the average THM grades for the -1mm/+20µm SAND samples for the remainder of Area 1 East, Domains 2 and 3. The weighted average grade from drill-hole samples within the Metallurgical Domain is 4.01% THM, whereas it was 2.01% THM, half the grade, for the remaining portion of Area 1 East estimated from the drill-hole samples. This difference between the respective grade estimates was attributed to having been derived from non-coincident areas within the resource.

When comparing the resource grades indicated by the metallurgical testwork with those from the drill-hole samples within the Metallurgical Domain, there is a grade uplift indicated by the metallurgical testwork of about 40%, from 4.01% THM in the drill-hole samples to 5.72% THM from the metallurgical testwork. This difference is attributed to differences between the drill-hole sampling and assaying methods within the metallurgical process flowsheet.

In Domains 2 and 3 of Area 1 East, Ordinary Kriging (OK) was initially undertaken using the samples from the +20µm SAND fraction. Subsequently, the major portion of Area 1 East was assigned the grades from within the Metallurgical Domain, which was measured from the metallurgical testwork. The bulk sample was subjected to a series of processing stages, after which the final head grade and MA were back calculated to produce data representing the entire bulk sample. This data was used to assign THM grade, SL, oversize, and MA to model cells that fell within the Metallurgical Domain,

thereby overwriting the values assigned to those blocks during the OK interpolation. The remaining portion of Area 1 East retained the OK estimates.

In Area 1 West, OK was undertaken, but using the sample assays for the +38µm SAND fraction. There is a significant difference between the Area 1 East and West grades, which is attributed to the different fraction sizes sampled and assayed. All Area 1 West Mineral Resource estimates were interpolated from samples collected from the +38µm SAND fraction and those Mineral Resource estimates are reported separately from Area 1 East.

6.2.3 Block model validation and classification

Cross-sectional slices of model blocks, drill hole traces and assays demonstrated that model cells honoured the drill hole data. For each of the mineralised domains, the input data composite mean was compared to the mean of the estimate. The two were sufficiently close to classify the Mineral Resource estimate as a combination of Measured and Indicated Resources; however, there is a degree of uncertainty in that the assaying method may understate the grades in all the mineralisation domains.

Swath plots representing slices through the block model along the three main axes were reviewed as part of the validation process. The average of each slice, together with the count of samples and blocks within each slice, allowed a visual assessment of the agreement between sample and slice averages. The comparison also indicated the amount of smoothing that resulted from interpolation.

In Area 1 East, Domains 2 and 3, the Metallurgical Domain grades for THM, SL and oversize were used to overwrite the estimated grades. The additional data acquired during the bulk sample testwork represents data that is superior to the simple assay values and better reflects the grades which will be recovered by the minerals processing plant. The Mineral Resource estimate over the metallurgical domain has been classified as a Measured Resource.

All domains that OK estimated were classified as Indicated Mineral Resources. They include portions of Area 1 East Domains 2 and 3 and all of Domain 5. All Area 1 West Mineral Resource estimates were estimated using +38µm SAND data and have been classified as Indicated Mineral Resources.

In preparing the Ore Reserve estimates, Auralia flagged the material that is currently considered unavailable for mining due to community and environmental considerations. These are largely areas in which there are trees to be preserved. The pit optimisations used to estimate Ore Reserves are used only the Mineral Resource estimate blocks that have been flagged in this manner.

The Area 1 Mineral Resource is shown in Table 6 and comprises 92.9Mt at an average of 3.44% THM, containing 3.2Mt of HM above a cut-off grade of 1% THM.

Table 6: Company Mineral Resource statement

Area	Mineral Resource Category	Material	In Situ THM	Bulk Density	Total Heavy Mineral (THM)	Slimes	Oversize material >2mm	THM Assemblage ⁽²⁾						Rare Earth Oxides													
								Zircon	Rutile	Leucoxene	Ilmenite	Monazite	Xenotime	CeO ₂	Dy ₂ O ₃	Er ₂ O ₃	Eu ₂ O ₃	Gd ₂ O ₃	La ₂ O ₃	Nd ₂ O ₃	Pr ₆ O ₁₁	Sm ₂ O ₃	Tb ₂ O ₃	Tm ₂ O ₃	Y ₂ O ₃	Yb ₂ O ₃	TREO
								(%)	(%)	(%)	(%)	(%)	(%)	(%)	(%)	(%)	(%)	(%)	(%)	(%)	(%)	(%)	(%)	(%)	(%)	(%)	(%)
Area 1	Measured	30.7	1.8	1.76	5.72	15	5	29.9	10.8	9.0	24.7	4.3	0.8	0.96	0.07	0.05	0.004	0.06	0.48	0.38	0.11	0.07	0.01	0.008	0.47	0.05	2.72
	Indicated	62.2	1.4	1.72	2.31	18	2	26.6	11.5	9.2	25.0	4.6	0.9	1.11	0.07	0.05	0.004	0.07	0.53	0.46	0.12	0.08	0.02	0.007	0.48	0.05	3.04
	Total⁽¹⁾	92.9	3.2	1.73	3.44	17	3	27.7	11.2	9.1	24.9	4.5	0.8	1.06	0.07	0.05	0.004	0.07	0.51	0.43	0.12	0.08	0.02	0.008	0.48	0.05	2.94
Area 2 West	Indicated	26	0.7	1.72	2.80	20	8	22.0	16.0	12.0	25.0	3.0	1.0	0.66	0.06	0.04	0.003	0.05	0.31	0.28	0.07	0.05	0.01	0.010	0.39	0.04	1.97
	Total⁽¹⁾	26	0.7	1.72	2.80	20	8	22.0	16.0	12.0	25.0	3.0	1.0	0.66	0.06	0.04	0.003	0.05	0.31	0.28	0.07	0.05	0.01	0.010	0.39	0.04	1.97
Area 3	Indicated	204.1	6.9	1.73	3.38	19	3	19.2	9.0	8.0	25.0	3.2	0.6	0.78	0.05	0.04	0.003	0.05	0.36	0.33	0.09	0.06	0.01	0.010	0.37	0.04	2.19
	Inferred	287.7	6.7	1.72	2.32	18	3	17.2	8.7	7.5	22.7	2.9	0.5	0.76	0.05	0.03	0.003	0.05	0.35	0.31	0.08	0.06	0.01	0.010	0.36	0.03	2.1
	Total⁽¹⁾	491.8	13.6	1.73	2.76	18	3	18.2	8.9	7.7	23.9	3.0	0.6	0.77	0.05	0.03	0.003	0.05	0.36	0.32	0.09	0.06	0.01	0.010	0.36	0.04	2.14
Area 4	Indicated	18	0.8	1.74	4.60	20	5	19.0	11.0	10.0	24.0	3.0	1.0	0.67	0.05	0.03	0.002	0.05	0.32	0.28	0.07	0.05	0.01	0.006	0.33	0.04	1.9
	Total⁽¹⁾	18	0.8	1.74	4.60	20	5	19.0	11.0	10.0	24.0	3.0	1.0	0.67	0.05	0.03	0.002	0.05	0.32	0.28	0.07	0.05	0.01	0.006	0.33	0.04	1.9
Grand Total	Measured	30.7	1.8	1.76	5.72	15	5	29.9	10.8	9.0	24.7	4.3	0.8	0.96	0.07	0.05	0.004	0.06	0.48	0.38	0.11	0.07	0.01	0.008	0.47	0.05	2.72
	Indicated	310.3	9.8	1.73	3.19	19	3	20.5	10.1	8.6	24.9	3.4	0.7	0.81	0.05	0.04	0.003	0.05	0.38	0.34	0.09	0.06	0.01	0.009	0.38	0.04	2.27
	Inferred	287.7	6.7	1.72	2.32	18	3	17.2	8.7	7.5	22.7	2.9	0.5	0.76	0.05	0.03	0.003	0.05	0.35	0.31	0.08	0.06	0.01	0.010	0.36	0.03	2.1
	TOTAL	628.7	18.3	1.73	2.92	18	3	20.2	9.6	8.2	24.1	3.3	0.6	0.81	0.05	0.04	0.003	0.05	0.38	0.33	0.09	0.06	0.01	0.009	0.38	0.04	2.25

	Material	In-Situ TREO Grade ⁽³⁾	In-Situ TREO
	(t)	(%)	(t)
Area 1, Area 2 West, Area 3, Area 4	628,703,134	0.07	413,107

Notes:
 Any discrepancies in totals are a function of rounding
 (1) Mineral resources reported at a cut-off grade of 1.0% THM
 (2) Mineral assemblage, via QEMScan Particle Analysis, is reported as a percentage of in situ THM content.
 (3) In-Situ TREO Grade is calculated by THM Grade (2.92%) multiplied by TREO Grade (2.24%)

Note: The Mineral Resource was prepared and first disclosed under the JORC Code (2012) in the Prospectus dated 21 November 2022 as supplemented by the supplementary prospectus dated 5 December 2022, lodged with ASX on 5 January 2023.

6.3 Area 3 Mineral Resource estimate

6.3.1 Geological interpretation and block modelling

Area 3 comprises a mix of near-surface high-grade strandlines and multiple stacked sheet-like deposits, within which three mineralised zones have been recognised as discrete domains.

Domain 1 comprises relatively high-grade, sheet-like mineralisation zones that are continuous along and across-strike. The high-grade (typically >2% THM) is interpreted to extend from the Orion deposit in the east to the Area 2 boundary in the west. The high-grade zones are open along all boundaries. Domain 2 has medium-grade zones (typically >1% THM) that occur above and below Domain 1. Domain 3 is interpreted to be an across-strike continuous, low-grade THM sequence with local zones of >1% THM.

In 2019, VHM collected downhole gamma values that were used in conjunction with THM grades to define zones of elevated zircon content. Sachets containing HM were made up and checked visually to distinguish valuable from waste material. The area of higher zircon content is Domain 1. Domain 2 was created in a similar manner by eliminating waste material after scanning the sachets. Typically, one sample per drill hole contained valuable heavy minerals.

Figure 6 is a diagrammatic interpretation of the mineralised domains.

Figure 6: Representation of a west-east cross section through the Area 3 Extended Resource Area, showing the relative location of the three mineralised domains (vertical exaggeration applied)

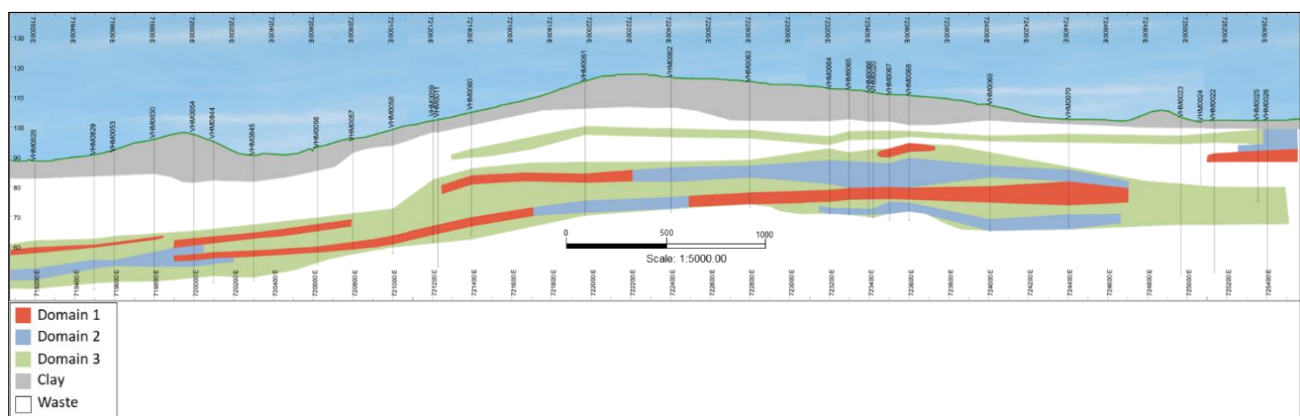

A block model was created to encompass the three mineralised domains. Interpolation of drill hole sample grades and assigning metallurgy testwork head grades and testwork outcomes to various zones were used to populate blocks within the model. Inverse Distance Weighting Squared (IDW²) was used to interpolate THM, SL and oversize into blocks.

The bulk sample taken from Area 3 was largely composited from drill samples taken from Domain 1. The metallurgical testwork used a bottom screen size of 20µm to de-slime the sample and showed a considerable uplift in HM grade compared to the average grade for the drill hole samples, which used a bottom screen size of 38µm. The MA and REE results from the bulk sample metallurgical testwork were assigned to Domains 1 and 2 Indicated and Inferred Mineral Resources, and the THM, SL and oversize grades were assigned to Domain 1 Indicated Mineral Resources. All other Domain 1 and Domain 2 Mineral Resource estimate grades for THM, SL and oversize were estimated into the block model from drill hole samples.

In 2020, many of the individual samples that make up the composite samples, and contain high trash and iron oxide minerals, were excluded from the compositing. New composites were made up from the remaining samples. These were used to calculate the MA and REE/ Rare Earth Oxides (REO) using QEMSCAN for the areas not informed by the 2018 bulk sample. Additional composites and

samples from Area 3 South were analysed for MA and REE grades and used to estimate THM, SL and oversize. MA and REE grades from these composites were interpolated into Domain 3 only.

6.3.2 Block model validation and classification

THM, SL and oversize were estimated using IDW² for Domains 1 to 3, except for Domain 1 Indicated Mineral Resources which were assigned grades from the bulk sample. Estimates were validated by swath plots.

In 2019, a program of work to re-assay samples from the Area 4 deposit was undertaken to understand the impact of using a 20µm bottom screen compared to a 38µm bottom screen for assaying. The results showed an increase in THM grade in all areas of the deposit. Further, mineralisation that had been characterised as sub-1% THM based on the 38µm bottom screen assays, became dominated by samples that were greater than 1% THM, thereby indicating a significant uplift in tonnes above a 1% cut-off grade. A similar program was conducted on samples from the Area 1 deposit, and the results showed similar outcomes to those at Area 4 i.e. a significant grade uplift.

As a result of these tests, and as the bulk sample had been analysed using a 20µm bottom screen, THM grades for Area 3 Domains 1 and 2 Indicated and Inferred Mineral Resources were assigned from the bulk sample. A consequence of assigning a uniform grade from the bulk sample is that every block has the same grade. This will not represent the spatial distribution of the THM or MA properties in a localised context, however, this is considered acceptable in a global sense, particularly given that bulk mining is proposed in the mine plan.

All three Domains have areas that have been classified as Indicated or Inferred Mineral Resources. The Indicated portion is relatively well informed by drill holes as well as by the bulk sample, although Domains 1 and Domain 2 are not well covered in the southern portion by the bulk sample. Domain 3 is informed by drill holes and the QEMSCAN data which, although not as densely drilled, covers the portion previously referred to as Area 3 South more fully.

The Area 3 Mineral Resource estimate is shown in Table 6 and comprises 492Mt at an average of 2.76% THM. The Mineral Resource estimate contains 13.6Mt of HM.

7. Hydrogeology

Mining will occur in the Loxton Sand, which hosts the regional water table. The Geera Clay is stratigraphically below the Loxton Sand and is an aquitard. Water table contours indicate that groundwater flows to the northwest and that water table fluctuations are relatively low across all seasons. Vertical hydraulic gradients are northerly, with groundwater level differences that suggest little risk of leakage into the Renmark Group aquifer below the Geera Clay.

The primary recharge mechanism in the area is the infiltration of rainfall. Primary discharge is throughflow to the north and north-west and is likely to the Murray River floodplain. There are no known permanent surface expressions of groundwater; for example, springs or seeps, within 10km of the Project area. The interpolated depth to water indicates that the water table is largely negatively aligned with topography. The groundwater salinity in the Loxton Sand renders the water unsuitable for agricultural uses.

7.1 Direct effects assessment

CDM Smith prepared an assessment of the direct effects on the groundwater environment. The assessment determined that there is a very low risk of acid or saline drainage from the tailings material, and only a moderate risk of tailings material becoming a source for soluble metals. The existence of a potential source does not automatically mean that there is a risk of contamination.

The Loxton Sand aquifer does not discharge to any known wetlands, lakes, or surface water features in the study area. There are no known permanent surface expressions of groundwater that interact with groundwater within 10km of the proposed Project area. Surface water that flows into the pit will be pumped out to keep the working areas dry, but it is not expected that the reduction in recharge will affect the regional water table.

Based on the available information, groundwater is not used for human consumption, stock watering, irrigation, or industrial purposes within 10km of the Project area.

It may be that some areas of the pit could be impacted by groundwater mounding. Should this occur, localised dewatering pumps will be used to ensure that the open pit floor remains dry. Any potential impact on mining will only occur in the operational pit cell adjacent to a tailings storage area. The duration of dewatering in any affected area will be from the end of extraction to the commencement of tailings deposition.

8. Hydrology

The Project will be located within the Avoca River catchment, between Lalbert Creek and Back Creek, which are distributaries of the Avoca River. A large number of constructed channels and drainage lines once traversed the area, which may have changed the course of the natural water flow. Most have now been decommissioned and filled-in since the construction of the Wimmera Mallee Pipeline Project.

The Avoca River has a history of flooding, with significant events in September 2010 and January 2011. The majority of floodwater leaves the river downstream of Charlton, where it spreads across the floodplain or through various anabranching waterways. Back Creek is part of the Avoca floodplain and is one of its anabranching waterways. It also drains a large local catchment to the west of the Avoca River and flows back into the Avoca River system at the Avoca Marshes. Lalbert Creek is an effluent stream of the Avoca River, carrying flood flows to Lakes Lalbert and Timboram. Lalbert Creek also drains a large local catchment.

Both Lalbert Creek and Back Creek intersect the Project area, with Lalbert Creek crossing the south-western corner. Back Creek originates on the eastern boundary and flows in an easterly direction into the Avoca River system. The local catchment is gently undulating, with a large, raised dune running north-south through the middle of VHM's tenements. Due to low rainfall, sandy soils with high infiltration and a gradually sloping land surface, the formation of natural waterways appears to be limited.

8.1 Riverine flooding

Flood modelling has been completed for a range of event magnitudes to determine the likelihood of flooding along the Avoca River, Tyrell Creek and Lalbert Creek, and their associated floodplains. The modelled flood depth from nearby waterways indicates that the area is generally unaffected by riverine flooding, with only the modelled flood extent from Lalbert Creek and Back Creek, touching the southwest boundary and the southeast boundary.

A 1% Annual Exceedance Probability (AEP) inundation occurs in the southwest and southeast corners of the expansion licence boundary but outside of the retention licence area. Depths greater than 1m are generally within the creeks, whilst overland flow above 0.3m may occur to the west of the licence area.

8.2 Local catchment behaviour

AEP hydraulic modelling indicates a 1% AEP event does not produce major external overland flow paths entering or exiting the Project area, with most inundation caused by relatively minor overland flow or a series of discontinuous depressions. The largest area of inundation occurs near the western boundary of the retention licence area, near Lake Lalbert. Velocities are generally low (less than 0.3 metres per second (m/s), with higher velocities observed in the steeper sections of the topography. The highest velocity (approximately 0.7m/s) is identified at the northwest of Area 1, south of Jobling Road.

8.3 Impact on water receptors

VHM intends to capture all runoff from disturbed areas (i.e., zero discharge off-site). Interception of water from the disturbed areas will temporarily reduce flow rates and volumes discharging to downstream water receptors. As only Area 1 will reduce the runoff to depressions to the east and Area 3 does not have any impact on surface runoff, the potential impacts on surface water receptors are limited to one farm dam at the northeast corner of Area 1.

8.4 Stormwater management strategy

A stormwater management strategy has been developed according to the following principles:

- Surface water runoff from disturbed areas will be directed to water management basins with the capacity to contain a 5% AEP volume.
- Captured water will be evaporated onsite or harvested to support uses such as land rehabilitation and dust suppression.
- Local secondary containment will be provided to contain runoff volumes up to a 1% AEP.
- Water management basins receiving water from disturbed catchments with potential to contain contaminants of concern will be lined.
- Surface water runoff from disturbed catchments that exceed the 1% AEP volume will be directed to the open pit or other receptors suitable for on-site storage.
- Surface water runoff from undisturbed and rehabilitated areas that meet water quality objectives will be returned to the environment.

9. Geotechnical Engineering

Geotechnical consultants pitt&sherry (P&S) have provided data assessment, geotechnical analysis, and recommendations. The P&S assessment includes:

- Pit-wall stability.
- A geotechnical engineering assessment related to in-pit tailings disposal.
- Geotechnical and civil engineering assessment for mining, civil and structural infrastructure, site investigations and laboratory testing.

Each of these will be discussed under the relevant sections of this document.

9.1 Geotechnical drilling and laboratory testing

Subsurface investigations were used to provide data for geotechnical assessments including:

- A limited drilling programme in 2017
- Hydrogeological drilling in 2021
- An extensive campaign in 2022 of specific geotechnical drilling and sampling, undertaken in parallel with resource investigation

Four geotechnical holes were drilled in Area 1 in 2017 using sonic methods. A Standard Penetration Test (SPT) was undertaken at selected intervals. Four hydrogeological drill holes were completed in 2021 by CDM Smith (CDMS) by wash boring methods. Undisturbed samples were taken at changes in soil visual appearance. In 2022 VHM, under P&S's supervision, completed further geotechnical drilling, including in situ and laboratory testing of subsurface materials.

Based on the available data, ground conditions encountered in Area 1 and Area 3 were assessed as having sufficiently similar characteristics to use a common ground model. The same soil units have been adopted for Area 1 and Area 3. Based on material strength variations with depth, pit design parameters were selected to minimise the risks associated with strength variations in the soil units over the site area.

9.2 Mine pit wall stability and recommended slope profile

9.2.1 Pit depth and design life

Pit depth is expected to vary, depending on ore grade profile and the depth to the groundwater table; all mining will be above the groundwater table. As mining advances and tailings are deposited into the mined-out void, there is a possibility that localised ground water mounding may occur. Dewatering pumps will be installed in affected mine blocks to ensure that mining and tails bund construction is carried out nominally 1m above the lowered water table.

The planned mining depth is generally 25-30m deep in Area 1. Due to an increased overburden thickness, Area 3 mining will generally be 35-43m deep, with one pit close to Jobling Rd reaching 47m deep.

9.2.2 Pit wall stability analysis

An analysis was carried out to determine the sensitivity of pit wall stability to changes in geometry, soil strata and other parameters. Based on the assessment results, it was recommended that for DFS purposes, pit slopes should have the geometry shown below.

Table 7: Recommended pit geometry

Geometry	Recommend limits	
Pit depth	30 m	40 m
Batter in clay	40° with a 6 m wide berm and a maximum bench height of 10 m	40° with a 6 m wide berm and a maximum bench height of 10 m
Batter in upper dense sands	50° with a 10 m bench, or 34° with no bench	45° with a 10 m bench, or 32° with no bench
Batter angle silty sand ore body	34°	32°
Minimum berm width	6 m	6 m
Overall slope angle	34°	31°

9.3 Stockpile stability and recommended geometry

A number of temporary stockpiles will be required over the mine life, including for topsoil, clay to construct tailings bunds and as a capping layer over process tailings/overburden backfill as part of the mine rehabilitation process and for mined overburden before its return to the pit voids.

The maximum height for topsoil stockpiles will be 3m to maintain the organic material close to its original condition and, therefore, suitable for supporting regrowth. Clay and sand overburden

stockpiles will be around 30m high, measured above the existing ground level. The stockpiles have been modelled with 4m berms and 6m lifts. A minimum factor of safety of 1.5 has been adopted for stockpile stability under static load and 1.1 under earthquake load. P&S considered these factors conservative. Their assessment concluded that 30m high stockpiles should be stable without special subgrade treatment.

9.4 Other considerations

Catch drains with bunds will be required to capture surface water runoff from stockpiles. Clay overburden material will be used to prevent erosion and scour. A number of sediment ponds for the storage of surface water runoff and removal of sediment will also be required. No liner is considered necessary from a geotechnical engineering point of view.

Haul roads have been designed for Caterpillar 785D mining trucks and a nominal 1m elevation above the existing ground surface. Haul roads have been designed in accordance with current mining practices.

A hydrology assessment using rainfall data sourced from the Bureau of Meteorology and other sources estimated runoff volumes for the total mine area, including a multiplier of 1.2 for climate change and another of 1.5 to convert from maximum flow to estimated design volume. The method assumed that all the rain falling on the mine area will be pumped to its final storage location, which will be the working mine void.

10. Ore Reserve Estimate

An Ore Reserve estimate and mining study were prepared at Pre-Feasibility Study (PFS) level by Auralia in March 2021 for Areas 1 and 3. Further work was completed to a DFS level in March 2022, with a combined Ore Reserve estimate and mining study completed within the footprint for the Project. This was constrained to the area that had land access approvals granted or pending as at the date of the Ore Reserve estimate, that is, December 2021.

Rare earths and zircon are the major revenue generators. Product quality has been largely confirmed during the DFS and is not materially different from previous trials. The market study has been updated with new product pricing during the DFS phase, based on independent reports from Adamas and TZ Minerals International Pty Ltd (TZMI).

Neither the December 2021 PFS or March 2022 DFS Ore Reserve estimate have been updated, with this document outlining the economic impact on the existing March 2022 DFS Ore Reserve estimate using recently acquired input parameters (including opex, capex and inclusion of a hydromet circuit).

Pit optimisations were completed using the newly acquired Phase 1 input parameters, namely the operating cost estimate and REMC sell price. Some minor differences between the existing pit designs and new optimisation shells were noted, however were determined to not be material. As such, the DFS pit designs were not changed. The net movement of the cut-off grade was also considered within the margin of error and therefore the Ore Reserve remains unchanged.

The Company is proposing to conduct an update to its Mineral Resource estimates in H1 CY2023 that will together with the input parameters outlined in this report be included in an updated Ore Reserve estimate.

The Mineral Resource estimate block models were used as the basis for pit optimisations and pit designs, scheduling, cash flow calculations and ultimately the Ore Reserve estimate and Ore Reserve statement. A 1.0% THM cut-off grade was selected for reporting purposes. Area 1 has a total resource of 93Mt (rounded) at an average grade of 3.44% THM, containing 3.2Mt of THM. The Area 3 resource comprises 492Mt at an average grade of 2.76% THM, containing 13.6Mt of THM.

10.1 Ore Reserve statement

The Ore Reserves have been estimated in accordance with the requirements of the JORC Code. The PFS and DFS Ore Reserves are shown in Table 8 and Table 9 respectively. The Ore Reserve estimate within the Area 1 and Area 3 pit designs are based only on Measured and Indicated Resources and include consideration of the modifying factors.

In Area 1, Measured Resources informed Proven Ore Reserves within the three paddocks over which the Company had land access agreements in December 2021. All Indicated Resources were converted to Probable Ore Reserves. In Area 3, there are no Measured Resources; Indicated Resources were converted to Probable Ore Reserves after applying the modifying factors.

Table 8: Company Ore Reserves

Area	Date	Classification	Ore	THM	Zircon	Rutile	Leucoxene	Ilmenite	Monazite	Xenotime	
			(Mt)	(%)	(%)	(%)	(%)	(%)	(%)	(%)	
Area 1	Mar-21	Proved	24.5	5.4	29.9	10.8	9.0	24.7	4.3	0.8	
Area 1	Mar-21	Probable	14.6	3.2	29.2	11.7	9.2	25.5	4.5	0.9	
Area 3	Feb-21	Probable	159.6	3.5	20.3	9.4	8.1	25.8	3.4	0.6	
Total											
			Proved	24.5	5.4	29.9	10.8	9.0	24.7	4.3	0.8
			Probable	174.2	3.5	21.0	9.6	8.2	25.8	3.5	0.6
Grand Total			198.7	3.7	21.7	9.7	8.2	25.7	3.5	0.6	

Area	Date	Classification	CeO ₂	Dy ₂ O ₃	Er ₂ O ₃	Eu ₂ O ₃	Gd ₂ O ₃	La ₂ O ₃	Nd ₂ O ₃	Pr ₆ O ₁₁	Sm ₂ O ₃	Tb ₄ O ₇	Tm ₂ O ₃	Y ₂ O ₃	Yb ₂ O ₃	TREO	
			(%)	(%)	(%)	(%)	(%)	(%)	(%)	(%)	(%)	(%)	(%)	(%)	(%)	(%)	(%)
Area 1	Mar-21	Proved	0.960	0.070	0.050	0.004	0.060	0.480	0.380	0.110	0.070	0.012	0.008	0.470	0.050	2.720	
Area 1	Mar-21	Probable	0.971	0.067	0.047	0.004	0.060	0.468	0.400	0.108	0.072	0.011	0.007	0.458	0.050	2.721	
Area 3	Feb-21	Probable	0.805	0.057	0.039	0.003	0.056	0.378	0.339	0.093	0.064	0.009	0.006	0.386	0.040	2.297	
Total																	
			Proved	0.960	0.070	0.050	0.004	0.060	0.480	0.380	0.110	0.070	0.012	0.008	0.470	0.050	2.720
			Probable	0.817	0.058	0.039	0.003	0.056	0.385	0.344	0.094	0.065	0.009	0.006	0.391	0.041	2.328
Grand Total			0.844	0.060	0.041	0.003	0.057	0.402	0.351	0.097	0.066	0.010	0.006	0.406	0.043	2.401	

Table 9: Goschen DFS Ore Reserves subset of global Company Ore Reserves

Area	Date	Classification	Ore	THM	Zircon	Rutile	Leucoxene	Ilmenite	Monazite	Xenotime
			(Mt)	(%)	(%)	(%)	(%)	(%)	(%)	(%)
Area 1	Mar-21	Proved	25.5	5.6	29.6	10.8	9.1	24.7	4.3	0.8
Area 1	Mar-21	Probable	7.6	2.2	27.6	12.7	10.5	25.9	4.3	0.9
Area 3	Feb-21	Probable	65.7	3.6	19.7	9.1	7.9	25.3	3.3	0.6
Total		Proved	25.5	5.6	29.6	10.8	9.1	24.7	4.3	0.8
		Probable	73.3	3.4	20.2	9.3	8.1	25.4	3.4	0.6
Grand Total			98.8	4.0	23.6	9.9	8.5	25.1	3.7	0.7

Area	Date	Classification	CeO ₂	Dy ₂ O ₃	Er ₂ O ₃	Eu ₂ O ₃	Gd ₂ O ₃	La ₂ O ₃	Nd ₂ O ₃	Pr ₆ O ₁₁	Sm ₂ O ₃	Tb ₄ O ₇	Tm ₂ O ₃	Y ₂ O ₃	Yb ₂ O ₃	TREO
			(%)	(%)	(%)	(%)	(%)	(%)	(%)	(%)	(%)	(%)	(%)	(%)	(%)	(%)
Area 1	Mar-21	Proved	0.960	0.070	0.050	0.004	0.060	0.480	0.380	0.110	0.070	0.012	0.008	0.470	0.050	2.720
Area 1	Mar-21	Probable	0.957	0.065	0.045	0.003	0.059	0.454	0.398	0.104	0.071	0.012	0.007	0.456	0.050	2.682
Area 3	Feb-21	Probable	0.795	0.056	0.038	0.003	0.055	0.373	0.335	0.091	0.063	0.009	0.006	0.383	0.039	2.271
Total		Proved	0.960	0.070	0.050	0.004	0.060	0.480	0.380	0.110	0.070	0.012	0.008	0.470	0.050	2.720
		Probable	0.806	0.056	0.039	0.003	0.055	0.379	0.339	0.092	0.064	0.009	0.006	0.388	0.040	2.298
Grand Total			0.862	0.061	0.043	0.003	0.057	0.415	0.354	0.099	0.066	0.010	0.007	0.417	0.044	2.451

11. Mining Strategy

Auralia Mining Consultants (Auralia) was engaged by VHM to undertake a mining study for inclusion in the March 2022 DFS. The mining study is limited to the area over which VHM has submitted a mining application to the Victorian government.

Pit optimisations using GEOVIAWhittle mine planning software were prepared using input parameters, including OPEX, processing recoveries and product prices derived by the DFS. The depth of mining was constrained by the water table but not constrained by paddock boundaries or surface vegetation. These constraints were subsequently applied during pit design work.

Pits have been designed with a single 40° upper bench in the soil/clay horizon with a six-metre-wide berm at the base of the clay layer, or 10 m below topography, whichever is lower. Below this berm is a single bench at 34° for overall pit depths less than 32 m, and 32° where the overall pit depth exceeds 32 m.

Complete extraction of ore is planned as a block/strip mining operation. Ore from the first mining block will be placed onto a surface ore stockpile. Subsequently, ore will be directly fed to an MUP. Process tailings will be deposited in tailings cells constructed in the mined voids. Waste mined from the initial mining blocks will be stockpiled on the surface until there is sufficient capacity and suitable conditions in the mined void to allow direct deposition to create tailings cell bunds or to cover consolidated tailings.

High-level scheduling of the mining and backfilling process has been completed, generally following the sequence shown in Figure 7.

Figure 7: Schematic illustration of mining sequence including progressive backfill and rehabilitation.

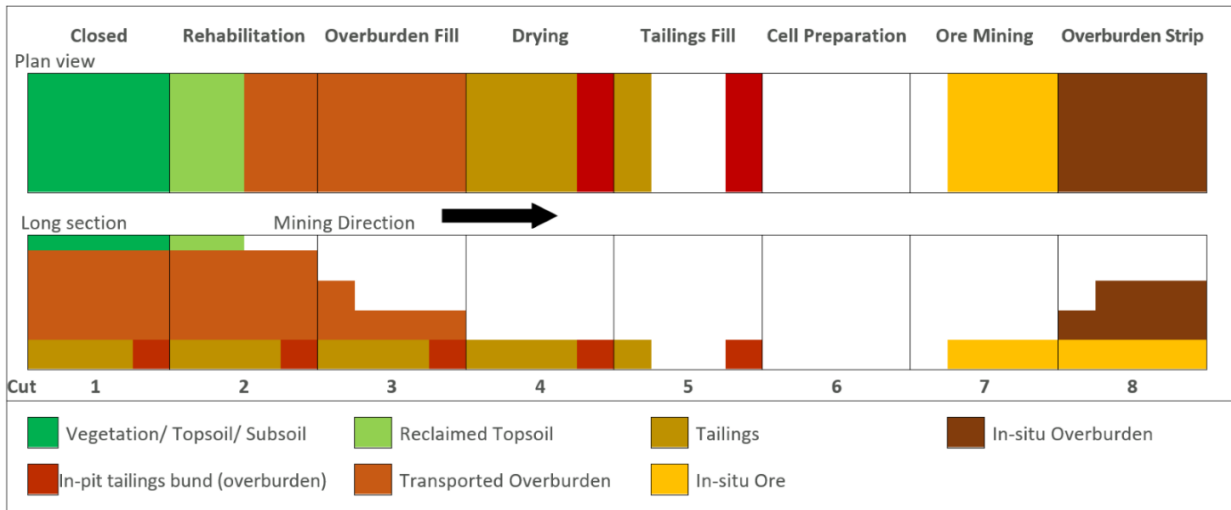

Mining will utilise a typical excavator and truck fleet, consisting of a combination of 200t and 110t class excavators and a fleet of 130t rigid off-road trucks. The primary load and haul fleet will be supported by bulldozers, scrapers, and front-end loaders, with graders and water carts used to maintain suitable operating conditions. It is expected that there will be no requirement for drill and blast, but dozer cross-ripping will be carried out as required.

Mining will occur in blocks, with excavation, tailings deposition and rehabilitation being undertaken in a progressive sequence. The proposed mining sequence has been optimised to allow for the deposition of homogenised tailings into each tailings cell within the mining block without the need for an above-ground TSF, and will continue to be optimised to minimise the time that tailings cells are open.

Mining will commence in Area 1, then progress to Area 3. Conventional open pit mining methods will be used for a mining operation which will be entirely above the water table. Mining blocks will be approximately 200m along-strike and variable in width to suit prevailing ground conditions. Excavators will be used to mine overburden and ore to load trucks which will transport the ore to the MUP, where it will be prepared for processing, and waste to either temporary surface stockpiles, in-pit tailings bunds or back into previously mined areas to cover process tailings. Primary mining operations will be supported by bulldozers and front-end loaders, which will be used for activities such as cross-ripping, pushing up bunds and contouring stockpiles.

Ore processing would then begin, with process tailings deposited directly into pre-prepared cells within the mined-out block. After consolidation, tailings will be covered by overburden as mining progresses to the next block, allowing for co-deposition to occur.

The proposed layouts for Area 1 and Area 3 are shown in Figure 8 and Figure 9.

Figure 8: Area 1 proposed layout

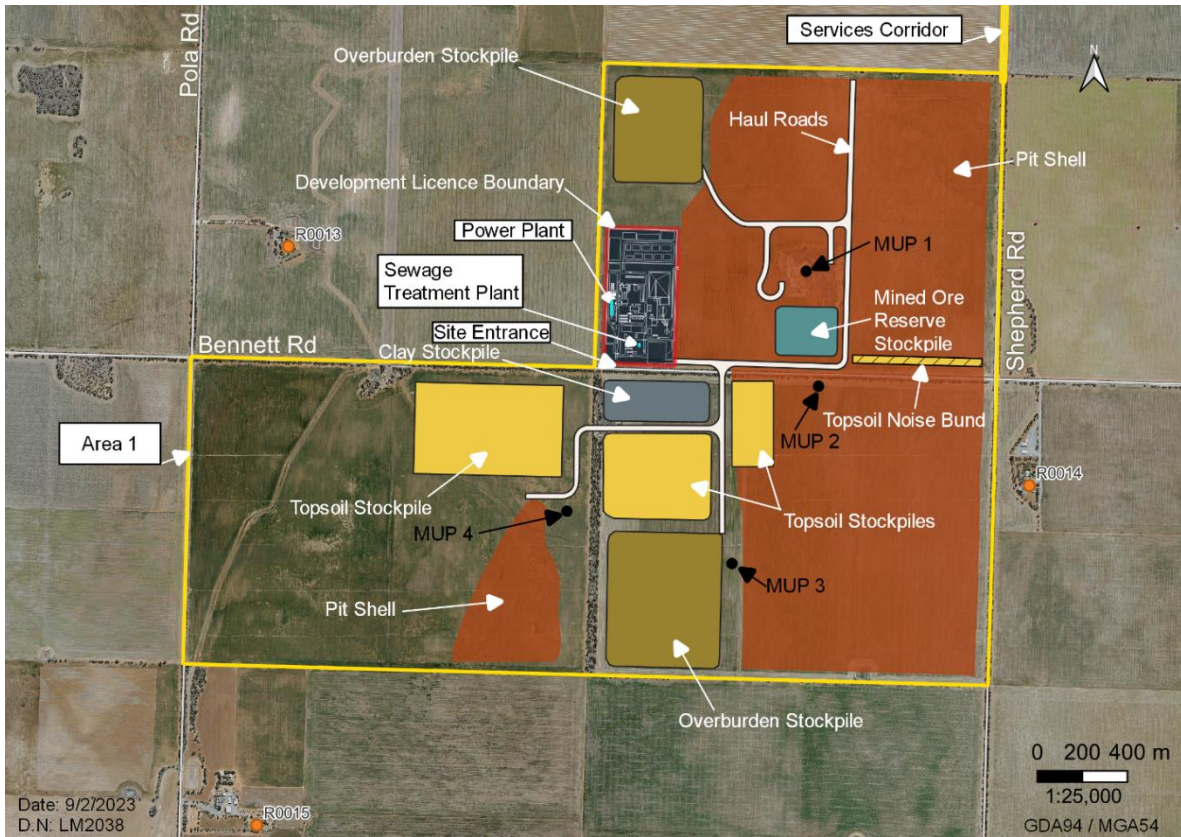
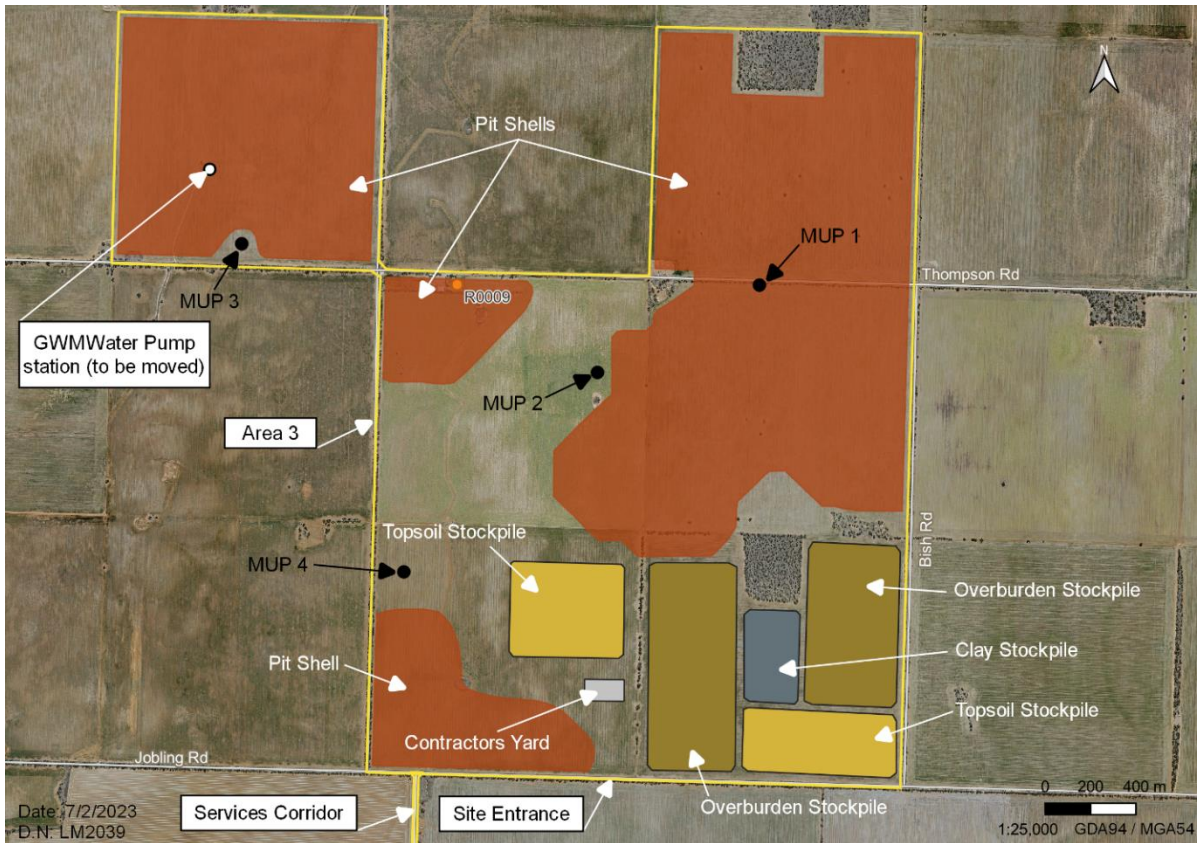

Figure 9: Area 3 proposed layout



The mining contractor will be responsible for loading ore into the MUP under the direction of the processing plant manager. The same (or similar) shift patterns will be used to ensure uninterrupted feed to the process plant. As mining has been scheduled to suit processing requirements, the processing feed schedule is very similar to the mining schedule.

The strip ratio will vary from 1:1 to 4.5:1. Annualised production rates will vary from 10 to 27.5Mtpa total movement (ore plus waste) to maintain the feed rate to the MUP at 5Mtpa. The mining production schedule approximated to five year periods is shown in Table 10.

Table 10: LoM mining schedule

Year:	0-5	6-10	11-15	16-21	LoM
Waste mining (Mt)	64.3	60.5	59.5	76.0	260.2
Ore mining (Mt)	24.7	25.1	25.0	23.9	98.8
Waste stockpile rehandle (Mt)	-	9.2	-	30.4	39.7
Total HM	4.9%	3.4%	3.3%	4.3%	4.0%
Zircon	29.1%	23.5%	19.3%	20.1%	23.5%
Rutile	11.3%	9.9%	9.0%	9.3%	10.0%
HGLX	9.4%	8.5%	8.0%	7.9%	8.5%
Ilmenite	25.0%	25.1%	25.2%	25.5%	25.2%
Monazite	4.2%	3.7%	3.2%	3.3%	3.7%
Xenotime	0.8%	0.7%	0.6%	0.6%	0.7%
Other HM	20.2%	28.6%	34.7%	33.3%	28.5%
SL	15.0%	16.7%	20.5%	16.0%	17.4%
Oversize	4.6%	3.6%	2.7%	3.0%	3.4%

Auralia completed a high-level cash flow analysis to ensure the proposed production schedule would produce a positive economic outcome.

A risk assessment did not identify any 'fatal flaws' in the proposed mining methods and mine production schedule. Further assessment and development of control measures in the lead-up to the commencement of operations will ensure that appropriate controls are implemented to effectively manage the identified risks. Opportunities exist to further improve economic returns during the implementation phase, or during operations, including, but not limited to, the removal of operating restrictions to allow full 24/7 operation in all areas and reviewing production sequencing to improve operating margins.

12. Metallurgical Testwork

An extensive program of metallurgical testwork has been completed with emphasis placed on confirming orebody characteristics, evaluating process options, and delivering product definition data to enable plant process specification and development of process flowsheet options.

The testwork systematically assessed the metallurgical performance of material sourced from Areas 1 and 3. The stages of processing envisaged for Phase 1 development include feed preparation, wet concentration, and a flotation circuit to separate a REMC from a bulk zircon-titania concentrate. Phase 1A will see the construction of a hydromet circuit to refine the REMC to MREC. Stage 2, if implemented, would see the construction of an MSP to produce separated zircon and a range of high-value titanium dioxide (TiO₂) feedstock products.

Mineral Technologies (MT) conducted the testwork, excluding the hydromet circuit testwork, and concluded that the ore could be treated with conventional off-the-shelf process plant technology. ANSTO (Australian Nuclear Science and Technology Organisation) completed the hydromet testwork.

12.1 Summary of programs

Testwork has been completed on material sourced from areas representative of mineralised zones. Drill hole composites from Areas 2, 3 and 4 were taken for initial characterisation, followed by more detailed characterisation of material from Areas 1 and 2. This was followed by a bulk testwork program involving the treatment of a 1.8t bulk sample from Area 3. Subsequent testwork was undertaken using a 9.1t bulk sample taken from Area 1. Additional bulk samples have been collected from Area 1 to recover approximately 100kg of REMC to enable testwork, product processing and evaluation through the hydromet circuit in Q2 2023.

The testwork program was designed to assess the metallurgical performance of Goschen ore through the stages of processing envisaged at full-scale operation. These include feed preparation, wet concentration, and flotation to recover a bulk zircon-titania concentrate and a REMC. Further testwork evaluated the conversion of the REMC into a mixed rare earths carbonate (Phase 1A). Although not a part of the Stage 1 development, testwork also included mineral separation of the HMC into final product streams to assess the indicative quality of products likely to be produced from the concentrates generated by an MSP.

The key testwork outcomes were that all ore samples tested were similar in terms of particle size and mineralisation. MT concluded that the ore can be treated with conventional off-the-shelf process plant technology to produce several final mineral products. Further testwork involving processing of the HMC through a MSP has also been undertaken to assess the viability of producing zircon, HiTi rutile, leucosene, and reduced chromium (Cr) ilmenite as final products. The outcome of the Area 1 bulk trial and the quality of products generated were used to inform the product specifications for pricing and mineral recoveries for plant design and financial modelling.

12.2 Phase 1A Hydromet Circuit

Comprehensive testwork was completed at ANSTO in 2018 as well as flowsheet evaluation testwork on a typical sample of REMC. The recent work demonstrated that the REMC is highly amenable to processing through to a high value upgraded MREC product. Based on the ANSTO testwork, the Company selected the Sulphate Bake (acid bake) route, as it provides the highest extractions of REM and the most robust economic case.

In May 2022, the Company commenced early testwork and process definition to establish a basis for further engineering studies. The core process design and modelling completed by GPA Engineering validated the feed throughput (including head grade and mineral assemblage), mass balance,

process design criteria, process flowsheet, reagent usage rates, utility demand and recoveries over the LoM Plan.

In preparation for pilot plant testwork, ANSTO has undertaken pre-pilot testwork using the acid bake and water leach route. The purpose of this work was to define piloting conditions such as acid addition, kiln temperature and reaction time. The pre-pilot testwork has demonstrated exceptional extractions >99% for the critical light rare earth metals (praseodymium and neodymium) and >98% for the critical heavy rare earth metals (terbium and dysprosium) into the water leach stage.

ANSTO continues with pre-pilot optimisation activities in parallel with the design and procurement of equipment for the pilot run, due to commence in Q2 of 2023. When complete, the pilot trial will demonstrate the feasibility of the entire flowsheet from REMC to the MREC product, including water and reagent recycling.

The pilot plant flowsheet developed by ANSTO for the production of REMC is shown in Figure 10.

ANSTO will commence hydromet pilot plant testwork in H1 2023, the results of which will feed into the engineering study scheduled thereafter. Piloting will give VHM detailed engineering solutions, the ability to order long-lead items for the hydromet circuit and provide a MREC product for market evaluation.

The Goschen REMC production process is considered industry-leading, not only in its ability to produce exceptionally high rare earth grade (>60% Total Rare Earth Oxide (TREO)), but also in the very high proportion of high-value critical rare earths neodymium, praseodymium, dysprosium, and terbium. These rare earths are essential to the automotive industries' transition from internal combustion engine to battery electric vehicles and plug-in hybrid electric vehicles.

Figure 10: ANSTO pilot flowsheet

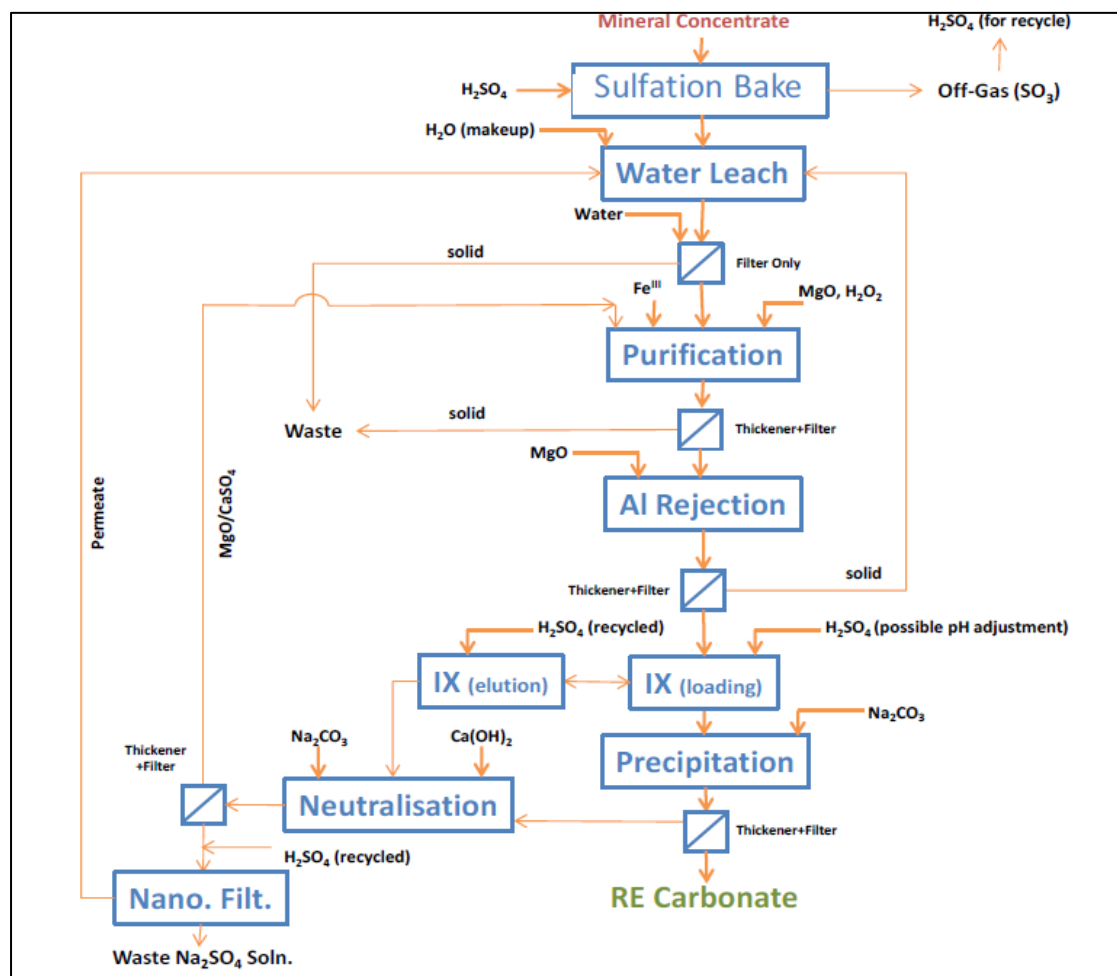

13. Process Engineering

Mineral Technologies is assisting VHM with the engineering and development of the mineral processing aspects of the Project, based on testwork that they have completed at their facility in Queensland. GPA Engineering has progressed the development of the hydromet circuit to a Class 5 estimate with process modelling and engineering based on testwork completed by ANSTO.

The process design assumes a throughput of 5Mtpa of dry Run of Mine (RoM) feed and uses tried and proven technology. The design is based on material with a nominal grade of 4.75% with ranges from 2-7% THM considered, and a nominal SL content of 15%.

As described previously Phase 1 of the mining process circuit would consist of a MUP, WCP and a REMC flotation circuit and after 6 months, Phase 1A would introduce a hydrometallurgical circuit. Phase 2 would consist of an additional MSP including optional HAL and chromium removal circuit and will be constructed and commissioned last subject to prevailing market conditions, financial considerations and sufficient additional funding being secured.

Table 11: Phased development of the processing plant

Phase	Assets
Phase 1 Concentrator	Goschen Project - Base Case, MUP, FPP, WCP, REMFC
Phase 1A Hydromet Circuit	Goschen Project - Expanded Case (addition of Hydromet Circuit)
Phase 2 MSP	Goschen Project - Wet MSP, Chromium-flotation circuit, Dry MSP

13.1.1 MUP

After mining, RoM ore will be stockpiled before feeding to the MUP by a front-end loader where it will pass over a grizzly to remove coarse oversize. Agglomerates of sand and clay will be broken down in a scrubber and the slurry pumped to the FPP at the main processing plant. The MUP is designed to be periodically relocated with moves incorporated into the mine schedule.

13.1.2 Feed preparation plant and wet concentrator plant

At the FPP, the SAND fraction, which contains the heavy minerals, will be separated from clay fraction (slimes) and the deslimed, screened SAND pumped to the WCP.

The FPP would be located at the main processing plant and would consist of coarse screening, fine screening, desliming cyclones and scavenging cyclones.

At the WCP, barren sand will be separated from the heavy minerals by spirals, which separate minerals based on differences between their specific gravities. HMC from the WCP will be pumped to the REMFC, whilst the sand rejects will be combined with the slimes and pumped back to the pit to backfill the mine void. The HM will be screened to remove coarse silicates and iron oxides that reduce the HM grade, whilst a final stage of cleaning will further improve the HM concentrate grade to around 92%.

13.1.3 Rare earth flotation circuit

A REMC (comprised mostly of the minerals xenotime and monazite) will be recovered from the HMC by flotation and gravity separation, leaving a post flotation (P-flotation) concentrate that is low in residual radioactivity. The REMC will be pumped to the hydromet circuit (Phase 1A, once commissioned) for processing, or packaged in drums as final product.

The P-flotation concentrate will be either pumped to the Wet MSP (Phase 2 – when constructed) for further processing, or dewatered and stockpiled, from where it will be conveyed to the product loading area as final product.

Figure 11: Phase 1 Schematic flow sheet

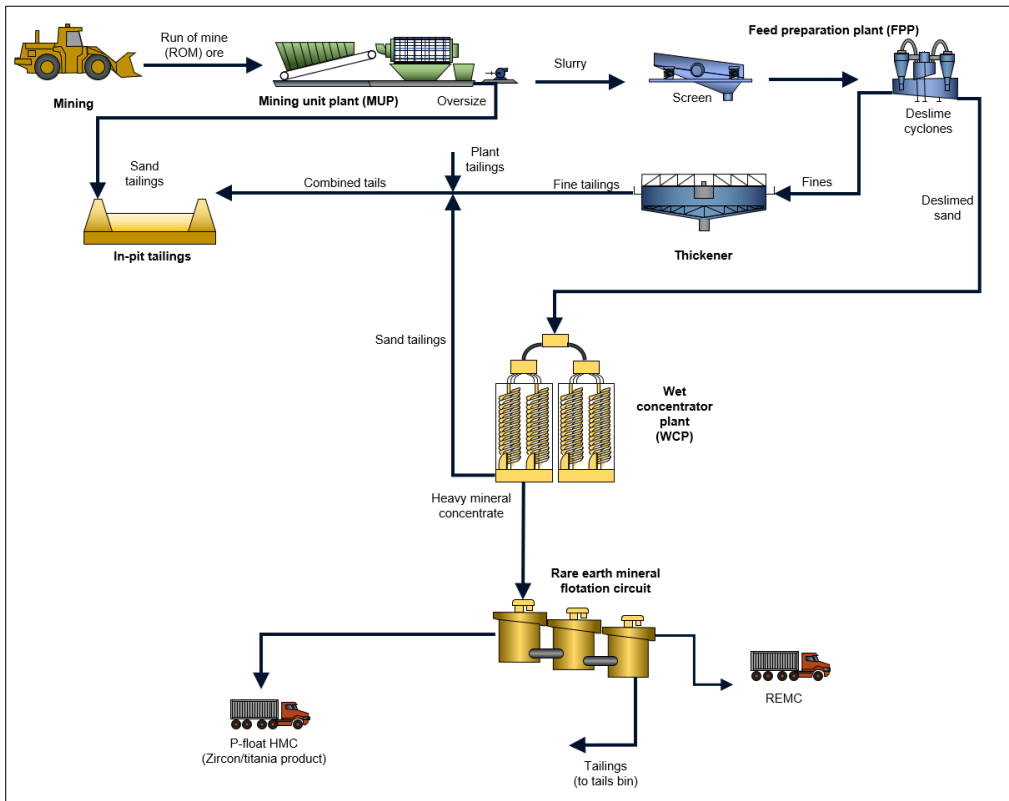

13.1.4 Hydrometallurgical circuit

The Phase 1A hydromet circuit will produce a MREC from the REMC. The REMC requires “cracking” with chemicals and heat to allow the rare earths to be extracted.

Sulphuric acid baking has been in use since the 1950s and is used almost exclusively for commercial treatment of refractory rare earth host minerals today. The sulphuric acid processing route is well known, and engineering challenges have been well documented.

The hydromet circuit will produce a mixed rare earth carbonate product from the REMC through a series of hydrometallurgical processing stages. These includes a sulphation bake, water leach tanks, purification, aluminium rejection, ion exchange and uranium processing and rare earth carbonate precipitation (Figure 12).

Figure 12: Phase 1A hydromet circuit schematic flow sheet

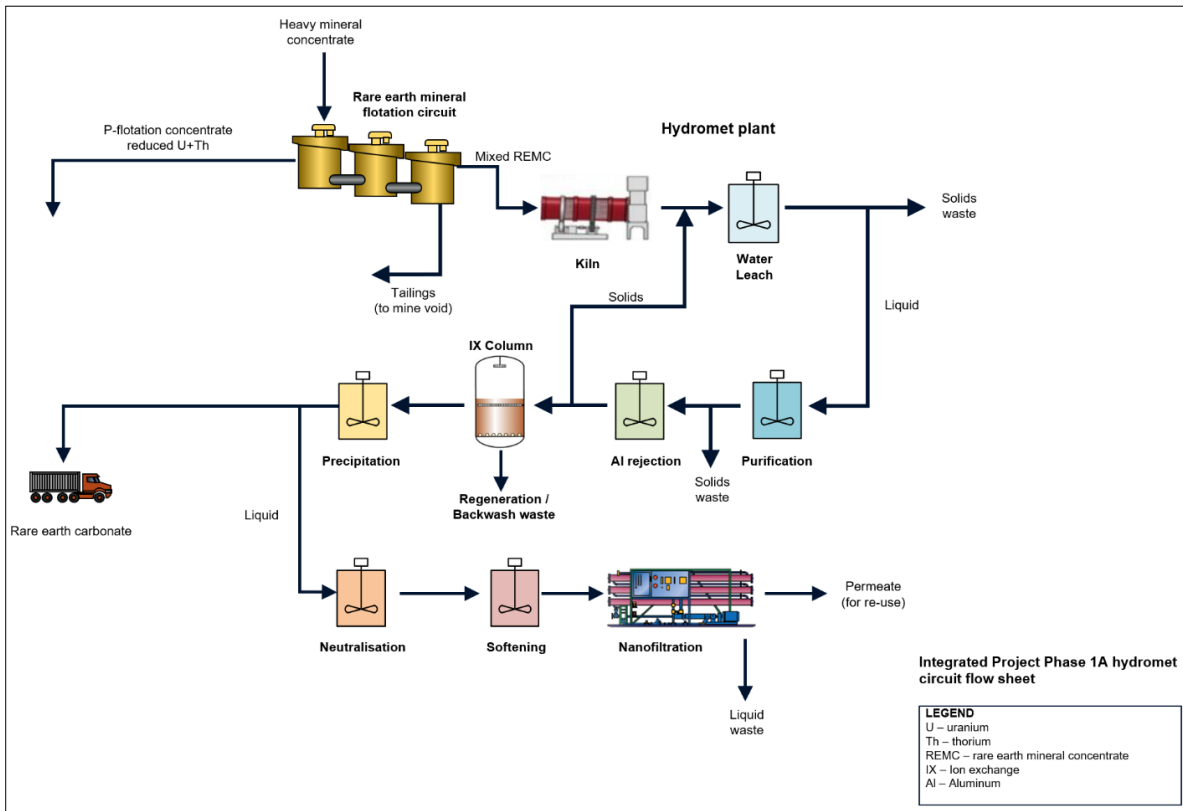

REMC would be dewatered in an indirectly heated electric dryer and would then discharge to sulphation bake acid mixer (a pug mixer) where concentrated sulphuric acid will be added to the dry solids to make a paste in preparation for baking in a gas-fired kiln. The sulphation process involves the conversion of the RE phosphate minerals monazite and xenotime and some impurities and gangue species into water-soluble sulphates.

Product from the sulphation bake kiln would then discharge into a water leach tank where it is contacted with recycled process water. The water leach process involves the solubilisation of the rare earth sulphate species generated in the sulphation bake.

The slurry leaving the water leach tanks would then be sent to a thickener, where the solid residue is diverted to a higher density underflow stream. This underflow would then be sent to a filter for further dewatering and washing, with the aim to produce a high density cake with minimal rare earth species for disposal.

The thickener overflow is primarily a liquor stream containing most of the dissolved rare earth elements. This stream would be sent to purification for further refinement.

The primary function of the purification stage would be to separate soluble phosphate from the rare earth liquor stream. In addition to phosphate removal, co-precipitation of other species also occurs. The slurry leaving the purification tanks is sent to a thickener. The thickener overflow is primarily a liquor stream and is sent to aluminium rejection for further refinement.

The aluminium rejection circuit involves the addition of magnesium oxide to adjust the pH. Under these conditions, the majority of any aluminium, iron and thorium metals would precipitate out of solution. Uranium would then be removed from the liquor via ion exchange and the rare earth elements would then be precipitated using sodium carbonate. This creates a high-grade, high purity rare earth carbonate precipitate. The resulting slurry will be sent to a thickener where the thickener

solids will be filtered for further dewatering. Solids from the filter will be washed with fresh water and sent to the MREC packing plant, where wet solids will be loaded into bulk bags for shipping.

The various effluent streams from the processing stages will undergo further treatment involving neutralisation, softening water recovery. Solids residues from water leach, purification and uranium precipitation will be collected in a tailings collection tank where the combined residues will be blended with the hot acid leach effluent stream as well as the brine produced in nanofiltration.

The tailings slurry leaving the tailings collection tank will be transferred to the tailings thickener from where the underflow will be pumped to a holding tank for disposal. Thickener overflow will contain mostly sodium sulphate in solution which will require further treatment before it can be re-used or disposed of.

13.1.5 Mineral separation plant

Phase 2 processing operations would introduce a mineral separation plant to separate p-flotation concentrate into final mineral products by exploiting differences in their physical properties such as; sizing, density, magnetic susceptibility, surface conductivity and hydrophobicity. There will be a tailings sump where all the tailings are combined and pumped back to the WCP tailings sump for homogenisation before returning to the mine void.

The first stage of separation would occur through a wet high intensity magnetic separation (WHIMS) producing a magnetic ilmenite rich stream and non-magnetic stream containing zircon and high TiO₂ titania minerals.

The magnetic ilmenite rich concentrate would be further processed in a flotation circuit to produce a low chromium ilmenite.

The non-magnetic concentrate would be processed through several conventional circuits in the wet and dry MSP circuits incorporating gravity separation, dry magnetic separation, and electrostatic separation to generate high quality final products of zircon, HiTi rutile and leucoxene. There is an option to treat the zircon through a hot acid leach to reduce uranium and thorium.

Reject streams rich in zircon and titania minerals would be collected and combined to produce a zircon/rutile rich concentrate.

An overview of the proposed concentrator process circuit for is presented in Figure 13 for Phase 2.

Figure 13: Goschen Project Phase Stage 2 concentrator schematic flow sheet.

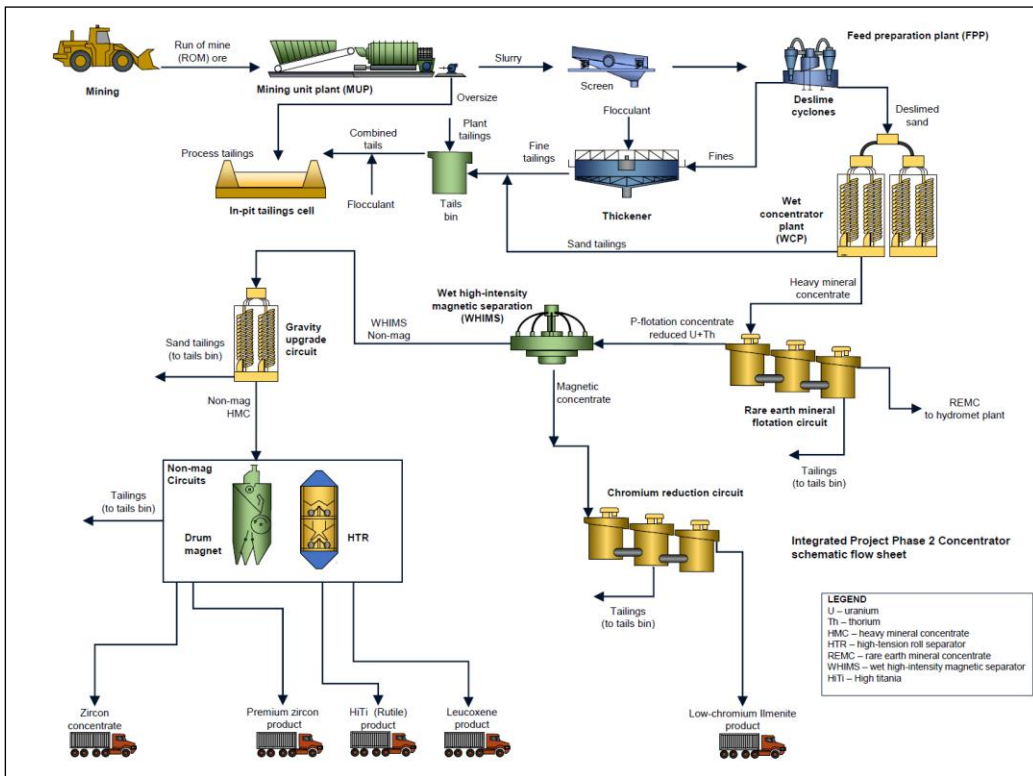

13.2 Site layout

The process plant will be centrally located on the western side of Area 1, on the northern side of Bennett Road. It will include the FPP, WCP, REMFC, MSP, Hydromet Circuit, and reagent storage, tailings thickener (and flocculant plant), process water dam, workshop, administration buildings, ancillary buildings, and plant, as well as HMC and P-flotation stockpiles, as shown below.

Figure 14: Proposed site infrastructure



Figure 15: Proposed site layout

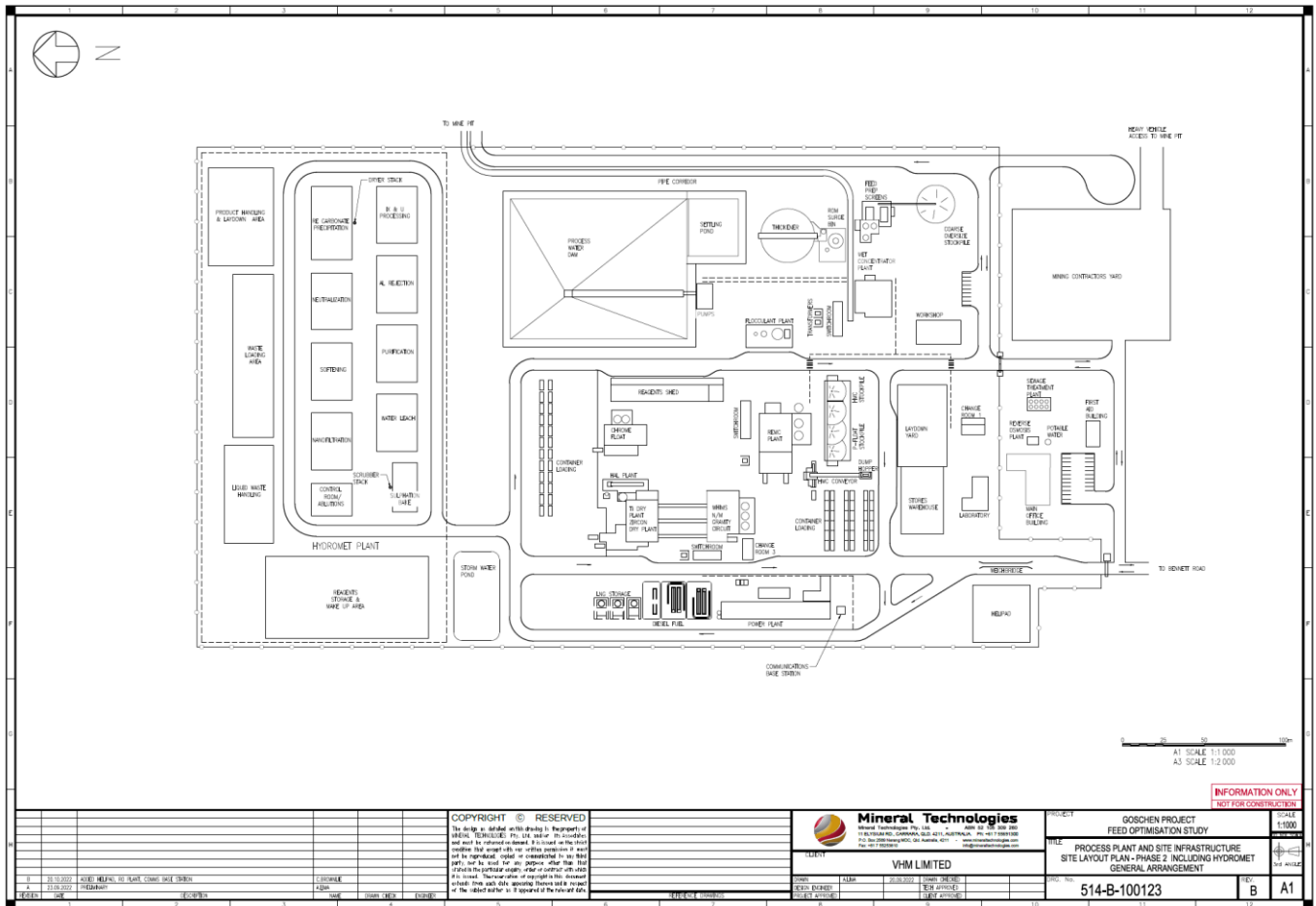

14. Tailings Management

Process plant tailings constitute the coarse, fine and clay fractions that remain once the valuable minerals have been recovered from the plant feed. Tailings streams from the WCP, REMFC and hydromet circuit will be transferred to a combined tailings sump, where they will be homogenised with the consolidated thickener underflow. The homogenised tailings are pumped back to the mining pit, where flocculant is added to aid water recovery. The released water is drawn off and pumped back to the process water pond to be re-used by the process plant. Once the available water has been recovered, and the tailings have been consolidated, they can be overlaid with overburden and rehabilitated.

The hydrometallurgy circuit will combine solid residues from water leach, purification, and uranium precipitation circuits along with the HAL effluent stream emanating from the concentrator plant. The effluent stream is neutralised, and the resulting tailings slurry is thickened and sent to the combined tailings hopper at the concentrator facility for subsequent hydraulic transfer with the concentrator tailings for in-pit deposition. Coarse tailings (+2mm) from the beneficiation plant are screened, stockpiled, and handled separately.

Co-disposal of tailings is a common method of managing tailings at mineral sands operations throughout the world. It enables rapid recovery of water, allowing the mined area to be rehabilitated quickly. It also reduces the overall mining footprint by excluding the need for a separate TSF.

As future phases are implemented (Phase 1A - hydromet circuit and Phase 2 – MSP and HAL) the same tailings deposition and water recovery system will be utilised. The system has been sized and designed to cater for all future phases.

Various studies and laboratory trials in support of the tailings management program have been undertaken to provide a data assessment, geotechnical analysis, and recommendations for inclusion in the DFS. The work focused on storage and rehabilitation in Area 1 and Area 3, with the emphasis on Area 1 as the initial mining area, and the area where mine planning is most advanced. It is expected that Area 3 will closely follow the approach taken in Area 1.

Once a block has been mined, overburden will be used to build an in-pit bund to create a cell to contain the deposited tailings. This will allow for tailings to be deposited in-pit without the need for a temporary above-ground TSF. Overburden can then be placed on top of the tailings so the area can be rehabilitated.

14.1 Tailings management plan

The Company engaged consulting engineering firm, ATC Williams (ATCW), to perform testwork on tailings samples to better define tailings behaviour and deliver a study in January 2023. This work will assist with the development of the final Tailings Management Plan.

The DFS tails management plan has been reviewed by ATC Williams, who concluded that:

- The proposed method of tailings management is not novel, and this, or similar approaches have and are being used at several active mineral sand projects across Australia.
- ATCW considered the proposed methodology to be the current best practice.
- The size and shape of the cells for tailings deposition will potentially have a major impact on the overall performance of the tailings management plan. Specialist laboratory tailings testing is proposed to establish critical design parameters before the final Detailed Design (DD) of the cells can be carried out.
- The maximum tails rate of rise within the mined-out cells needs to be determined with tailings deposition and consolidation modelling. The assumed constant 3% slope for tails deposition in all cells may overestimate volume and should be reviewed through modelling and refined during the design stage.
- The choice of not including an above-ground or off-line TSF is achievable, however, this will delay financial return as the process will be delayed until sufficient in-pit storage is available.

During the next stage of project development, VHM will optimise the tailings deposition plan by undertaking a gap analysis and further work to improve the efficiency of the tailings cells and operations.

15. Infrastructure and Utilities

15.1 Geotechnical assessment

15.1.1 Foundations for plant structures and ancillary buildings

For any structural foundation footprint, the existing topsoil (clay sometimes up to 1.5 m thick) should be removed. To restore natural ground levels, sand fill should be used to limit the settlement of structures. For DD, individual structures should have site-specific geotechnical investigations to comply with building standards and provide data for engineering design.

15.1.2 Hard stands

It is expected that the clay material will not be trafficable when wet. Hard stands are likely to require a 150mm thick working platform during construction. Permanent hard stands, which will be unpaved and unsealed, should have a 500 mm thick layer of crushed rock as a road base layer. The 500 mm could include the working platform. The addition of 3% to 4% of hydrated lime to the clay subgrade is also an option to improve the strength of hard stands.

15.1.3 Access roads

A full-depth flexible pavement has been designed for two assumed subgrade conditions: a California Bearing Ratio (CBR) of 10% and a CBR of 5%. In areas where the subgrade has a CBR of less than 5%, some form of treatment should be executed, which could be in the form of 500mm subgrade replacement with CBR 10% material sourced from the sand overburden. As an alternative, in situ stabilisation of the clay could be undertaken by the addition of hydrated lime.

Asphalt surfacing should be used in areas where it is likely that there will be slow speed turning movements and the possibility of trucks screwing their wheels. P&S recommended a 40 mm AC14 asphalt layer as suitable for heavily trafficked areas.

15.2 Water supply

Water will be drawn from Kangaroo Lake and pumped to site via a dedicated pipeline. The supply system includes an intake pump station at Kangaroo Lake and a 38km pipeline to the process water pond at the mine. The design includes two electrical skid-mounted 400 kilowatt (kW) horizontal pumps located on the banks of Kangaroo Lake. Each motor will be connected to a common switchboard. Electricity will be drawn from the Powercor electricity grid, with back-up power to be available from a 1.5 MVA diesel-powered generator.

An on-site water treatment plant will provide potable water stored in a tank facility for site distribution as needed. Water will initially be trucked until the water supply system has been established. Water will be recycled as far as is practicable. A packaged Wastewater Treatment Plant (WWTP) will be installed as part of the construction and will treat wastewater from showers, toilets, and sinks. Raw sewage will also be fed to the WWTP.

15.3 Power supply

On-site power will be provided by a third-party contractor using nominally 12 x 11kV high-voltage dual-fuel generators. The power station will operate with ten duty generator sets operating at around 75% full load and two standby units for maintenance and in the event of breakdowns. The power station has been sized for a nominal connected load capacity of 12.0MW and will be of sufficient capacity to provide a reliable electrical energy supply to operate the mine, process plant and ancillaries 24/7. Power will be distributed throughout the site via low voltage transformers.

During the construction phase, temporary power will be provided by construction contractors.

The fuel storage facility will comprise above-ground self-bunded diesel tanks and Liquefied Natural Gas (LNG) gas bullets with an individual capacity for 10 days of operations. The on-site fuel depot will be regularly supplied by fuel tankers.

The Company will aggressively pursue the opportunity to transfer to renewable technologies as they become available and commercial viability increases.

16. Marketing

This section outlines the state of the downstream markets for the Project products in Q4 2022 and future developments expected. Market analysis was commissioned from Adamas Intelligence (Adamas) for the rare earth market and TZ Minerals International Pty Ltd (TZMI) for the titanium mineral and zircon markets. Both the TZMI and Adamas reports were received in January 2023.

This section includes a discussion of the suitability of Project products to end-uses within these markets as well as the prices they are expected to achieve.

16.1 Rare earth products

From 2022 through 2035, Adamas Intelligence forecasts that global TREO demand for permanent magnets will rise at a Compound Annual Growth Rate (CAGR) of 8.3%, from 87,000 tonnes to 246,000 tonnes, boosted by strong demand growth from electric vehicle, wind power, general automotive and other applications of NdFeB (Neodymium-iron-boron) magnets.

Specifically, from 2022 through 2035, Adamas forecasts that global TREO demand for passenger Electric Vehicle (EV) traction motors, commercial EV traction motors and “other e-mobility” applications will collectively increase at a Compound Average Growth Rate (CAGR) of 14.0%, together representing the single largest demand driver.

Moreover, from 2022 through 2035, Adamas projects that global TREO demand for direct drive and hybrid direct drive wind power generators for onshore and offshore applications will rise at a CAGR of 13.0% as the increasingly competitive economics of wind power generation (and low maintenance of direct drive generators) continue to spur rising adoption.

From 2022 through 2035, Adamas forecasts that global TREO demand for all other end-uses and applications of NdFeB permanent magnets will increase at CAGRs of 3.4% to 5.4%, forgoing market share to electric vehicles, wind power generators and other high-growth applications.

By 2035, Adamas projects that permanent magnets will drive 60% of global TREO demand by volume and over 95% of the market’s value each year.

16.2 Forecast REO prices to 2035

As per its latest “Rare Earth Pricing Quarterly Outlook” report (Q1 2023), Adamas forecast annual average prices for each rare earth oxide to 2035 under three scenarios, and the Company has adopted the Base Case scenario.

16.2.1 Base case

In the Base Case, Adamas forecasts that magnet rare earth prices will trend steadily higher from 2022 through 2025 on the back of increasingly tight supplies and rapidly growing demand for EV traction motors, wind power generators and other applications of NdFeB magnets.

From 2025 through 2029, however, Adamas expects that battery materials and/or other component shortages will slow the EV market’s growth by 15% to 30%, leading magnet rare earth prices to more-or-less plateau over the four year period.

Thereafter, from 2029 through 2035, Adamas projects that the EV market will return to unhindered growth, exacerbating the imbalance between global supply and demand while sending magnet rare earth prices steadily higher through the end of the forecast period.

16.2.2 REMC price outlook

Adamas forecasts that rare earth mineral concentrate from Goschen (61.4 wt. % TREO) will have a value of \$10.16 to \$12.15 per kilogram of concentrate in 2023 and will increase overall to \$18.35 to \$23.03 per kilogram in 2035 (Figure 16).

Figure 16: Adamas Intelligence Goschen REMC price outlook

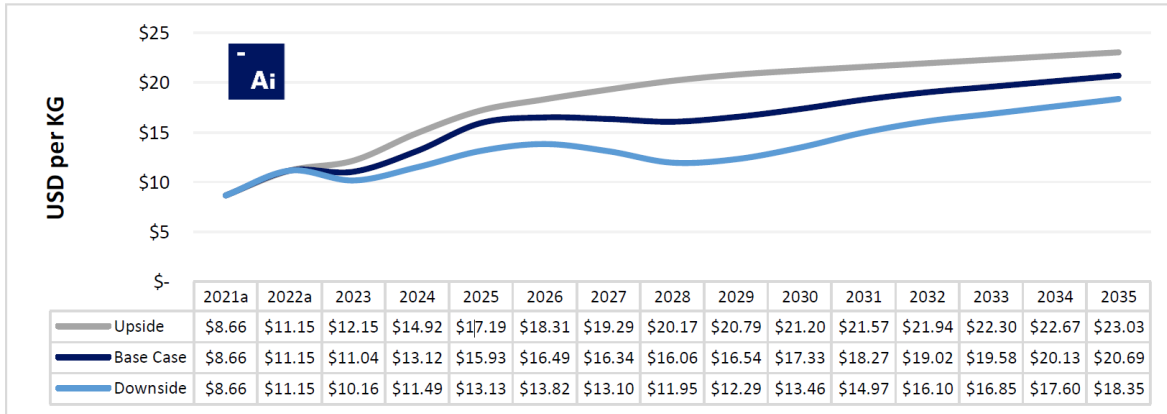

- * Prices in USD per kilogram of concentrate; concentrate contains 61.4 weight % TREO.
- * China REO and concentrate prices used as basis for forecasts, along with company-provided assays.
- * All prices include 13% VAT; forecasted prices are in Real 2023 dollars.
- * If selling into China, 13% VAT should be deducted from the above; if selling ex-China, the prices above should be taken at face value.

16.2.3 MREC price outlook

Utilising the Base Case, Adamas projects that MREC chemical precipitate from Goschen (59.7 wt. % TREO) will have an average value of \$18.67 to \$22.30 per kilogram of precipitate in 2023 and will increase overall to \$33.62 to \$42.21 per kilogram in 2035 (Figure 17).

Figure 17: Adamas Intelligence Goschen MREC price outlook

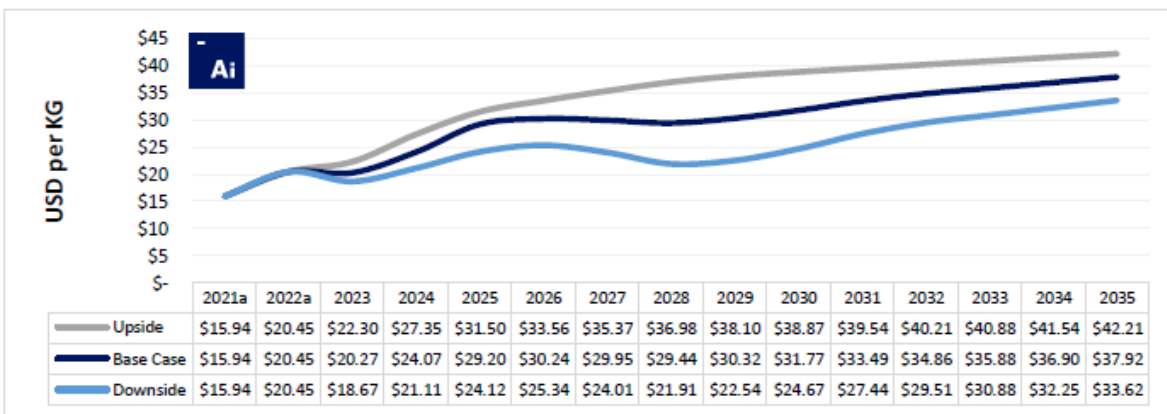

- * Prices in USD per kilogram of concentrate; concentrate contains 59.7 weight % TREO.
- * China REO and concentrate prices used as basis for forecasts, along with company-provided assays.
- * All prices include 13% VAT; forecasted prices are in Real 2023 dollars.
- * If selling into China, 13% VAT should be deducted from the above; if selling ex-China, the prices above should be taken at face value.

16.2.4 NdPr oxide price outlook

After more than doubling since 2020, Adamas expects China’s domestic price of NdPr oxide may increase upwards from US\$120/kg in 2023 to US\$205/kg in 2030 (Figure 18).

Figure 18: Adamas Intelligence Goschen NdPr price outlook

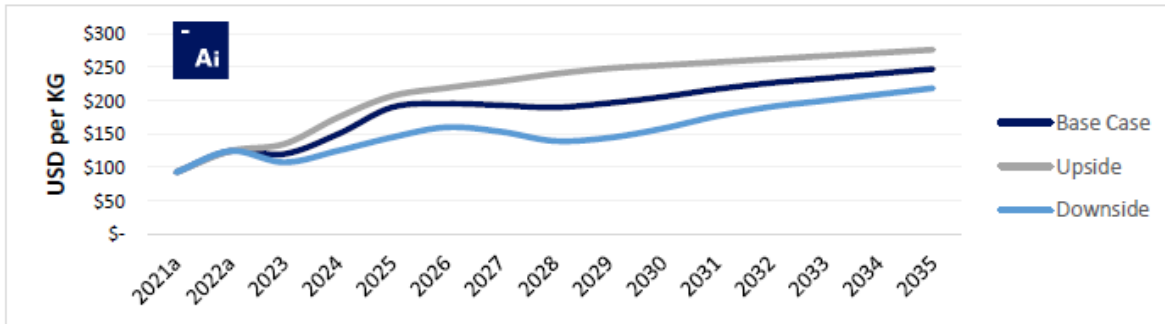

* Forecasted prices are in Real 2023 US dollars and include 13% VAT; if selling into China, VAT should be deducted; if selling ex-China prices above should be taken at face value

16.2.5 Forecast Goschen basket value from 2022 through 2035

Taking Adamas Intelligence’s latest Base Case price forecasts into account, along with relative distribution of rare earth oxides in MREC from Goschen (see Figure 17), the Goschen basket value (i.e., value of rare earth oxides contained in one kilogram of separated TREO produced from the project) was projected for each year from 2022 through 2035, as shown in Figure 19.

In Adamas’ Base Case, Upside and Downside price forecast scenarios, the Goschen project basket value will increase from 2022 through 2035 at a CAGR of 4.9%, 5.7% or 3.9%, respectively.

Figure 19: Forecasted Goschen basket value from 2022 through 2035

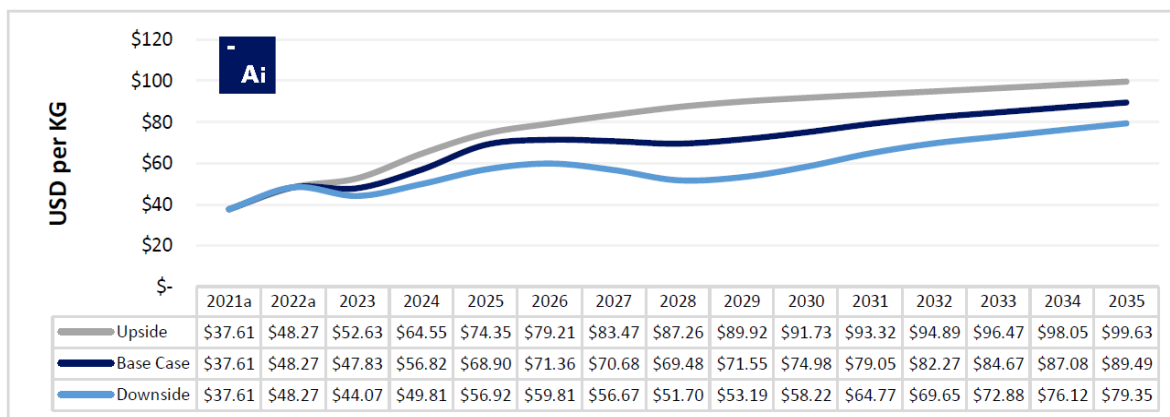

* Basket values include 13% VAT; forecasted prices in Real 2023 dollars
 * If selling into China VAT should be deducted; if selling ex-China above prices should be taken at face value

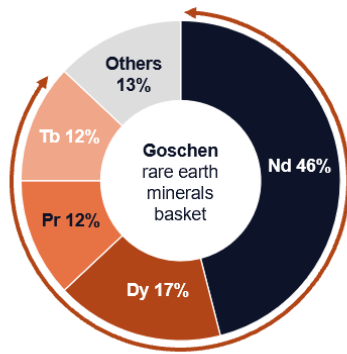

87% of Goschen’s REM basket value will be derived from high value dysprosium, neodymium, praseodymium, and terbium oxides, all of which are high demand ‘critical’ rare earths used in permanent magnets for EV traction motors, wind power generators, among others and included in the US and Australian Government list of critical minerals.

16.3 Mineral sands products

16.3.1 Phase 1 zircon–titania HMC product

Phase 1 of the Project will result in the zircon and titania minerals remaining unseparated and contained in the zircon-titania HMC.

There is a ready market for mineral concentrates containing zircon and titania minerals. Targeting sales to Chinese concentrate processors, a long-term price of US\$530 per tonne Free On Board (FOB) (on a real 2022 dollars basis) is expected.

Production of the zircon-titania HMC is expected to average 134,500 tonnes per annum during the first 10 years and contribute average annual revenue of \$135m in nominal terms, accounting for 35% of total project revenue in Phase 1 and 24% for Phase 1A, as greater rare earth revenues are derived from the MREC sales.

17. Capital Cost Estimation

The Project will be delivered in a phased approach as presented at a high-level in Table 12.

Table 12: High-level project delivery capex estimate summary by phases.

Phase	Scope	CAPEX A\$	Expected Date of Initiating Implementation Expenditure
Phase 1	MUP, FPP, WCP, REMC & assoc. NPI	\$376m	H1 2024
Phase 1	Pre-production mining & other ancillary start-up works	\$106m	H1 2024
Phase 1A	Hydromet & assoc. NPI	\$124m	H2 2024
Phase 2	MSP (incl HAL) & assoc. NPI	\$160m	H1 2025

All capital expenditure estimates are in Australian dollars (A\$). They have been compiled with contributions from various consultants to a DFS detail (except for the Hydromet Circuit, which is only completed to a Class 5 level of accuracy), following the Association for the AACE International and Australasian Institute of Mining and Metallurgy (AusIMM) guidelines, which are aligned to industry standards.

The estimates cover the detailed design and implementation phases for related processing plants, and on-site and off-site infrastructure and reflect the capital to complete the facility ready for operations.

The capex, inclusive of process plant and supporting NPI, owner's costs, operational readiness costs, pre-production costs and contingencies, have been estimated by various consultants and compiled by VHM. It includes both direct and indirect costs. No forward escalation has been included.

All estimates have been compiled on the assumption that the Project phases will be executed by one or more Engineering, Procurement and Construction (EPC) contractors engaged by VHM.

Cost efficiencies will likely be realised in the event phases are implemented in parallel where it is practicable to do so.

Post commissioning sustaining capital costs are estimated to be around 1% (annually) of total capital spend in the early years of operation.

17.1 Phase 1 summary (concentrator)

Phase 1 consists of the MUP, FPP, WCP and REMC plant and associated NPI requirements. The total estimated capex for Phase 1 is A\$483m, inclusive of contingency of A\$28m.

The DFS level estimate is based on a Project design and development accuracy range of $\pm 15\%$ for the scope indicated.

Table 13: Total project CAPEX Phase 1 cost estimate summary by discipline

Description	Total (A\$m)
Directs	234.3
Earthworks	65.1
Civil/concrete	12.2
Buildings and NPI	8.4
Structural steel	22.2
Platework	7.83
Process and mechanical equipment	43.5
Piping and valves	48.9
Electrical, controls and instrumentation	20.9
Spares and first fills	2.6
Mobile equipment	2.5
Indirect	77.6
Engineering Services, Contractors & Expenses	72.9
Owner's Costs (labour, expenses & insurances)	4.6
Total capex (excluding line item contingency)	407.9
Value of line item contingency	47.0
Total capex (including line item contingency)	455.0
Value of Project contingency	28.0
Total capex (including Project contingency)	483.1

17.2 Phase 1A summary (Hydromet Circuit)

A Class 5 estimate has been developed in conjunction with GPA Engineering for Stage 1A.

The estimate allows for the total installed cost of process equipment, including basic NPI, and indirect costs associated with freight, insurance, and construction extras. The total estimated capex for phase 1A is A\$124m, inclusive of contingency.

In Q1 CY2023, GPA Engineering completed a Process Design Validation Study Report. This study aimed to develop an Advancement of Cost Engineering (ACE) Class 5 Cost Estimate based on actual vendor quotes for fundamental plant and equipment materials. Various deliverables were specified to support the Capital Cost Estimate and to inform the Operating Cost Estimate. These deliverables are based on the 2019 proof-of-concept testwork by ANSTO, with input from vendors, together with budget quotes.

The Overall Delivery Cost Estimate for the hydromet circuit is \$124m, including 7.5% contingency (\$8.7m). GPA's estimate includes the total installed cost of process equipment, including basic infrastructure directly related to processing equipment and indirect costs associated with freight, insurance, and construction extras. VHM nominated allowances for non-process Infrastructure (NPI) (services, utilities, and buildings) and indirect costs associated with process plant vehicles etc.

17.3 Phase 2 summary (MSP)

For Phase 2 MSP (if approved to proceed), the additional Project facility to be implemented would consist of the MSP, which is generally made up of the wet circuit, dry circuit, ilmenite upgrade chrome removal circuit, zircon HAL circuit and associated NPI.

The estimate for Phase 2 was completed to a DFS level of $\pm 15\%$. Assuming Phase 2 is approved to proceed, the total estimated capex for Phase 2 is A\$159.8m inclusive of contingency of 7.5%.

18. Operating Cost Estimate

This operating expenditure estimate for Phase 1 & Phase 2 of the Project has been compiled and determined with contributions from various consultants to a DFS detail following the Association for the ACE International and AusIMM guidelines, aligned with industry standards. This opex estimate is presented in Australian dollars (A\$) and has a base date of Q1 CY2023.

The estimate covers operating labour, contracted services, mining services, consumables, maintenance and running costs over the LoM for all related on-site and off-site services. The estimate reflects the operations of a facility operating at an annual RoM ore feed processing rate of 5Mtpa.

DFS level values have been scoped and acquired for all area/circuits comprising the Phase 1 of the Project, including the MUP, FPP, WCP, REMC plant and associated NPI.

Similarly, DFS level estimates have been completed for Phase 2 of the Project with respect to the MSP.

Class 5 estimates have been completed for Phase 1A of the Project, the hydromet circuit.

Upon formal operational commencement of Phase 1, expected in H1 CY2025, the total estimated annual opex estimate for the Project is A\$148.6m.

With the additional formal operational commencement of Phase 1A, expected in H2 2025, the total estimated annual opex estimate for the Project is A\$205.3m.

Assuming Phase 2 is approved to proceed, the total estimated annual opex estimate for the Project is A\$229m.

No contingency value has been assigned for the opex estimates.

The estimates for Phases 1 and 2 have an accuracy range of $\pm 15\%$ for the scope indicated, based on the pricing sources received; no forward escalation has been included. They have been compiled on the assumption that the Project will be fully commissioned and have commenced operations by March 2025.

18.1 Basis of DFS Refresh opex estimate

The opex estimate is based on the following parameters:

- All operating cost estimates are based on a typical year of production assessment, assuming 5.0Mtpa processing capacity
- A base date of Q1, CY2023
- A full production year based on 7,446 operating hours per annum (85% plant availability) for the MUP, FPP and WCP
- Key costs associated with operations generally relating to the following are included:
 - General site administration and site operational services
 - Contracted site maintenance services
 - Mining services
 - Tailings and rehabilitation
 - Process plant operations and maintenance
 - NPI operations and maintenance
 - Electric power generation
 - Diesel and LNG consumption
 - Reagents and consumables
 - Product transport and logistics

The opex estimate summaries for all Phases are presented in the tables below.

Table 14: Phase 1 operating cost estimate summary

Area	Cost (A\$m)	% (approx.)
Mining Contractor	\$ 58.5	40%
Tailings & Rehab Contractors	\$ 5.0	3%
Site Management	\$ 8.8	6%
Site Services	\$ 15.7	11%
Process Plant	\$ 31.5	21%
PowerStation	\$ 13.8	9%
Water Pump Station & Pipeline	\$ 3.5	2%
Product Transport & Logistics	\$ 11.7	8%
Total	\$ 148.6	100%

Table 15: Phase 1A operating cost estimate summary

Area	Cost (A\$m)	% (approx.)
Mining Contractor	\$ 58.5	28%
Tailings & Rehab Contractors	\$ 5.0	2%
Site Management	\$ 8.8	4%
Site Services	\$ 15.7	8%
Process Plant	\$ 83.7	41%
Power Station	\$ 18.4	9%
Water Pump Station & Pipeline	\$ 3.5	2%
Product Transport & Logistics	\$ 11.7	6%
Total	\$ 205.3	100%

Table 16: Phase 2 operating cost estimate summary

Area	Cost (A\$m)	% (approx.)
Mining Contractor	\$ 58.5	26%
Tailings & Rehab Contractors	\$ 5.0	2%
Site Management	\$ 8.8	4%
Site Services	\$ 15.7	7%
Process Plant	\$ 99.9	44%
Power Station	\$ 26.0	11%
Water Pump Station & Pipeline	\$ 3.5	1%
Product Transport & Logistics	\$ 11.7	5%
Total	\$ 229.1	100%

19. Financial Evaluation

19.1 Project financial evaluation assumptions

- Pre-tax nominal NPV discount rate of 10%
- Valuation date is January 2023
- REMC and MREC product prices per Adamas forecast received in January 2023
- All long term prices beyond 2030 assumes the same price as 2030 (in real 2022 dollars)
- All long term prices beyond 2035 assumes the same price as 2035 (in real 2023 dollars)
- Long term AUD / USD exchange rate of 0.70
- Short term CPI inflation in accordance with RBA published forecasts in November 2022
- Phase 1 first production in H1 2025
- Phase 1A first production in H2 2025
- Capex and opex estimates in real 2023 dollars

The DFS demonstrates strong financial returns and sustained high-margin cash flows (Table 17). The Project's Phase 1 and Phase 1A NPV₁₀ (pre-tax) of approximately \$1.5 billion, together with the long life, robust cash margins and IRR of 44%, demonstrates the Project's viability and provides a compelling commercial case for advancing the Project.

The DFS financial analysis is based upon capital, cost and revenue assumptions derived from market engagement, including equipment, transport and materials suppliers, and industry experts for independent product pricing, long term foreign exchange rate forecasts and near and longer term inflation rate forecasts. Economics for the DFS Refresh are based on the DFS Ore Reserves associated with Area 1 and Area 3 and capital and operating cost forecasts refined during the DFS and this DFS Refresh. Project start-up is associated with high-confidence approvals, construction, and a commissioning schedule. Unless otherwise stated, financial data in this Chapter 19 are expressed in nominal terms.

Table 17: Goschen Project financial metrics

Goschen Project key financial and operational metrics		Phase 1	Phase 1 and 1A
Pre-tax NPV ₁₀ (A\$m)		700	1,525
Pre-tax IRR		33%	44%
Payback from commencement of production		3.4 years	2.8 years
Pre-prod capital cost (A\$ million real 2023)			
- Mine and processing facilities		376	124 (incremental)
- Ancillary expenditure		106	
Ore Reserve LoM		20.5 years	20.5 years
Processing capacity (ore Mtpa)		5Mtpa	5Mtpa
Average ore grade (THM)		4.0%	4.0%
Average strip ratio (waste: ore)		2.6 : 1	2.6 : 1
First 10-Years of Mine	REMC average production (tpa)	9 428	9 428
	MREC average production (tpa)	-	8 568
	Zircon-titania HMC average production (tpa)	134,500	134 500
	Average revenue per annum (A\$m)	387	564
	Average opex per annum (A\$m)	218	273
	Average EBITDA per annum (A\$m)	169	291
	Average unlevered, pre-tax FCF per annum (A\$m)	156	270
	Average revenue A\$/t ore	81	118
	Average operating cost A\$/t ore	46	57
	Mixed rare earth carbonate composite Price A\$/kg (US\$/kg)	27 (19)	49 (35)
	Zircon-titania heavy mineral sands contained minerals composite price A\$/t (US\$/t)	1 193 (835)	1 193 (835)

As the DFS only considers 50% of the identified Ore Reserves, subject to future regulatory approvals and assuming the continued application of the core assumptions used for the DFS Ore Reserve, mining the maximum ore reserve estimate of 198.7Mt would extend the life of mine to approximately 40 years, with resultant indicative unrisks pre-tax NPV₁₀ increased to approximately \$2.1 billion, and IRR of 45% for Phases 1 and 1A.

19.2 Revenue, operating cost, and margin

Applying the financial assumptions outlined in Section 19.1 above, the following chart (Figure 20) outlines the substantial revenues generated by the Goschen project, A\$560m pa averaged over initial 10 years as well as the relative contributions of the rare earths and minerals sands product revenues, respectively, 76% and 24%.

The considerable EBITDA margins of 50% (average over initial 10 years) as well as the dual product stream, provide key mitigating benefits to address potential adverse product price volatility.

Figure 20: Revenue, operating cost, and margin chart for Phase 1 and 1A

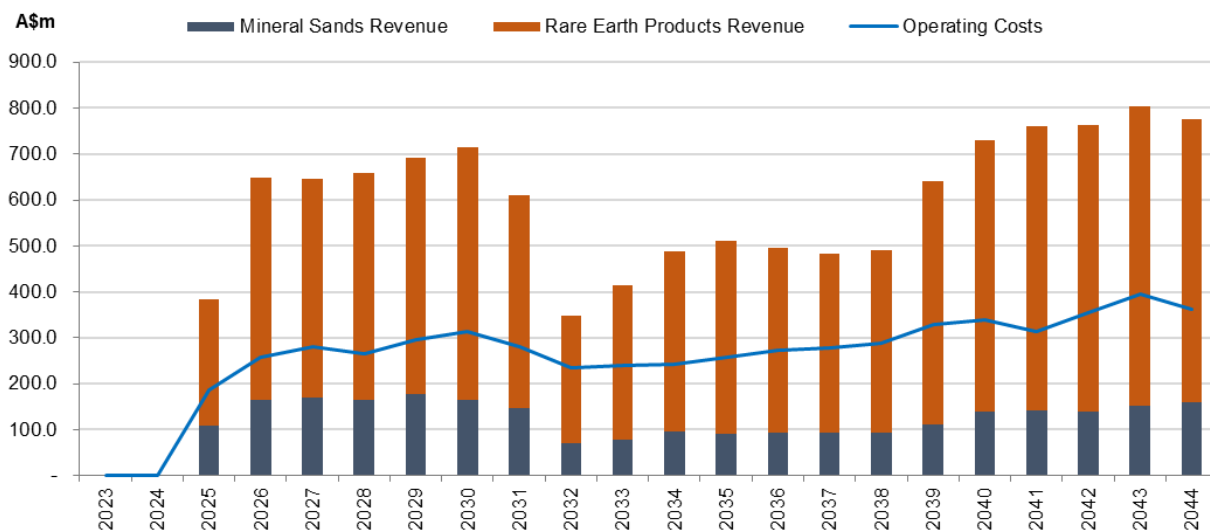

19.3 Estimated cash flow

Estimated average Earnings Before Interest, Taxes, Depreciation, Amortization and Exploration (EBITDAX) for Phase 1 and Phase 1A for the initial 10 years of production is approximately A\$291m per year whilst average annual pre-tax FCF is A\$270m once production commences, which is expected to be in H1 2025.

The DFS illustrates that the Goschen Project has strong and sustained annual FCFs as reflected in Figure 21 below.

Figure 21: Goschen Project Phase 1, and 1A pre-tax FCF

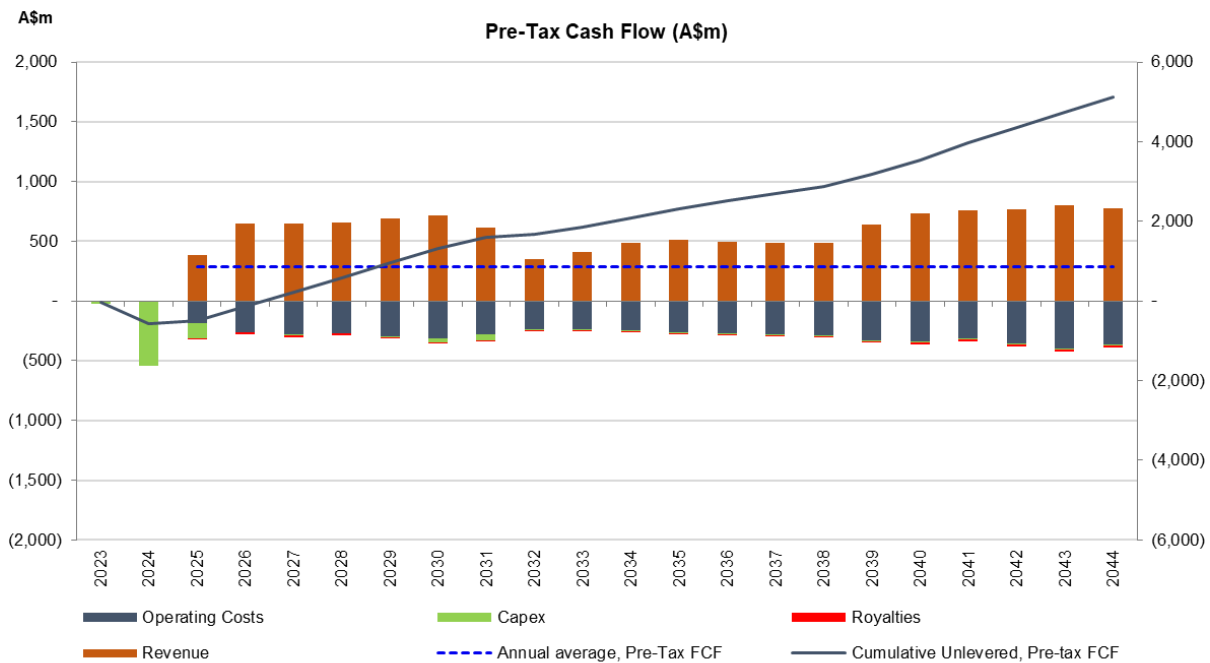

19.4 Sensitivity analysis

A sensitivity analysis of the Goschen Project economics has been carried out considering the forecast product prices, AUD/USD foreign exchange rates, mining, and processing opex and capex costs. The chart below indicates the impact.

As would be anticipated, given the Project's high revenue margin derived in US dollars; largely from sales of rare earth products, the Project's forecast NPV is sensitive to rare earth price movements and exchange rate movements. Conversely the sensitivity analyses indicate that the Project is relatively less sensitive to variances in capital costs, and operating costs, largely as a result of comparatively low development capital costs and low project operating costs.

Sensitivities are applied to key project estimates and assumptions. Favourable and unfavourable movements relative to the Project's unrisks NPV₁₀ value are illustrated in for Phase 1 and 1A.

Figure 22: Sensitivity of NPV applied to key project estimates and assumptions

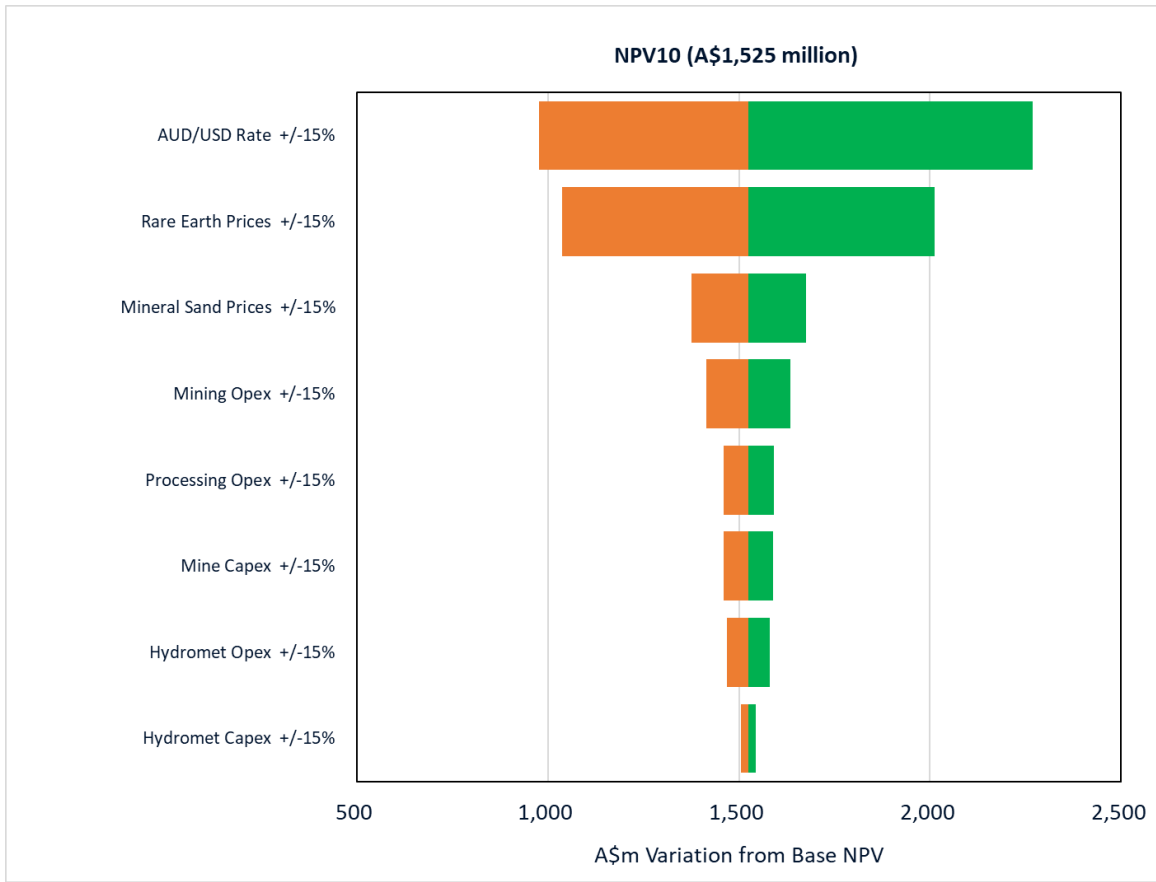

19.5 Financing and funding structure

As noted above, the Project has strong economics with:

- a multiple product suite with growing global demand and projected global supply shortfalls
- forecast strengthening product price support
- large reserves and resources base (both for the Goschen Project and expansion opportunities)
- comparatively low initial and sustaining capex
- relatively modest opex
- generating long life, sustained high-margin free cash flows
- enabling near term payback once production begins

Accordingly, the Project is considered financeable with capital requirements to be met with a combination of equity and debt.

Such potential financial support is further enhanced by the increasing desire of both equity and debt providers to meet their respective environmental, social and governance (ESG) investment mandates. Given that the rare earths to be produced by the Project are the fundamental building blocks for the renewables sector (particularly electric vehicles and wind farms) and the Project has sound financial metrics, it is expected to attract interest from domestic and international managers of globally substantial volumes of ESG capital. There is no guarantee that any debt will be obtained by the Company, or obtained to the extent the Company anticipates it may require for the schedule set out

in this DFS Refresh, including but not limited to, any potential financier's views regarding the Project's proposed dual-fuel generators.

Debt capital funding opportunities may also be available in conjunction with product offtake agreements, either directly by way of pre-payment facilities, or indirectly through credit support arrangements. Finally, the introduction of third parties in the Project as joint venture participants, should that occur, may reduce VHM's development funding requirements, and provide funding solutions assuming consideration for the acquisition of the interest is by way of cash and/or carried expenditure.

Based on the DFS Refresh analysis, aggregate capital requirements to a point at which the Project has completed commissioning, is estimated to be US\$500 million/A\$700 million (nominal).

Debt capacity will be determined taking into account customary project finance debt sizing measures, such as loan life cover ratios, project life cover ratios and a reserves tail, as well as lender views on an appropriate debt-to-equity mix. The ratio of debt-to-equity mix will also depend on VHM's other operational requirements.

VHM will progress discussions with prospective Australian and international commercial lenders during 2023, with the objective of securing a substantial project debt facility with financial completion achieved on receipt of all regulatory approvals. VHM will also progress opportunities for available government supported grant and debt funding and credit support at the same time.

VHM will seek to raise this remaining equity at, or around the time of, the Project FID and finalisation of a committed debt facility, expected to be in H2 2023.

20. Resource and Expansion Upside

20.1 Future exploration and project development

VHM's focus is on the development at Goschen, which is primarily located within RL6806. The estimated Ore Reserves have the potential to underpin a long-life mine; the current Ore Reserves estimated in Area 1 and Area 3 combined (199Mt) are sufficient for a project life of up to 40 years at a throughput rate of 5Mtpa. The DFS Refresh considers a mine life of only half this at 99Mt. Ore Reserves are expected to increase as existing Mineral Resource estimates are drilled to sufficient levels of confidence to sustain upgrading to Ore Reserves, and further mineralisation is defined by extensional and exploratory drilling.

The objective of VHM's exploration has been to discover and delineate further HMS comprising zircon and titania minerals (rutile, leucosene, and ilmenite) and REMs (monazite and xenotime) associated with the sheet-style and strandline deposits that are common throughout the Murray Basin.

20.2 Resource extension exploration

The Company is required as part of its tenement expenditure commitment to advance resource definition programs. VHM intends to continue exploration over its tenements to expand the current Proved and Probable Ore Reserves, and to identify areas of high-grade mineralisation that may be incorporated preferentially within the LoM plan.

Resource definition will be prioritised in Area 2 East, Area 2 West, and Area 4 as these are proximal to the Goschen development. Planned exploration drilling has been extended into the adjacent EL6419.

The Company considers the surrounds of the Goschen development to offer further development opportunities and is highly prospective for the discovery of both sheet and strandline-style deposits. The focus of exploration in the near to middle term will be on resource extension drilling in Area 1, Area 2 West, Area 3, and Area 4, as well as infill drilling to increase resource confidence. Further exploration is planned at Cannie and Nowie.

20.3 Cannie and Nowie prospects

VHM is required (pursuant to the conditions attached to the grant of its ELs) to undertake further exploration drilling and associated activities to meet tenement expenditure commitments. The exploration will be Low Impact Exploration as defined in the *Mineral Resources (Sustainable Development) Act 1990*, which only requires notification to Earth Resources Regulation seven days prior to the commencement of works. However, new land access rights will be required should any drilling be planned on private land.

Cannie and Nowie have been identified as exploration target areas comprising both sheet-style and strandline accumulations of HM. These areas are mostly at a relatively early stage of exploration. In 2021, the Company undertook close-spaced airborne geophysics, which has confirmed a geophysical response occurs over the Cannie and Nowie areas. This response coincides with rare earth and zircon–titanium mineralisation intersected by drill holes in historical exploration.

VHM commenced drilling in January 2023. The planned program comprises up to 120 holes at Cannie and up to 70 at Nowie, totalling 5,700m of AC drilling. It is estimated that the program will take approximately two months to complete. The primary objective is to define the extent of mineralisation and support future maiden Mineral Resource estimates at both sites.

20.4 Goschen Exploration Target (GET 2022)

20.4.1 Background

VHM had previously released an Inferred Mineral Resource estimate for Goschen North, referred to as the 2017 Goschen North Mineral Resource estimate. As there was very limited MA data available for the 2017 Mineral Resource estimate, an assumed MA for valuable heavy mineral was applied to some of the data set greater than 1% THM. In the second quarter of 2022, a review of the 2017 Mineral Resource estimate indicated materially higher grades for THM, valuable heavy mineral and REM assemblages compared to the earlier estimate.

20.4.2 Exploration by VHM

Between 2017 and 2019, new resource definition AC drilling replaced a significant portion of the historical drilling in the Goschen North area. In 2018, LiDAR surveying indicated that the HM mineralised horizons are both closer to the surface and vertically thicker when compared to the 2017 Mineral Resource estimate. The cause of this discrepancy was attributed to survey errors in drill hole collar positions by previous exploration companies. Resurveying the collar coordinates for each historical drill hole confirmed a significant change in the vertical position of the mineralised horizons.

The assay methodology for the data used to support the 2017 Mineral Resource estimate used different screen sizes to generate the SAND fraction for assay, and there was no assaying for REMs. The data was therefore considered inadequate for an assessment of the potential for future expansion at Goschen, and the 2017 Mineral Resource estimate was downgraded to an exploration target, the Goschen Exploration Target (GET) 2022.

As required by the JORC Code, the Company notes that the potential quantity and grade of the GET 2022 are conceptual in nature, that there has been insufficient exploration to estimate a Mineral Resource estimate and that it is uncertain if further exploration will result in the estimation of a Mineral Resource estimate.

20.4.3 Derivation of exploration target

In the AC holes drilled by VHM, the sheet horizons were defined at a 0.8% THM cut-off grade, supported by downhole gamma logging. The sheet horizons are laterally extensive and can be traced over several kilometres both north-south and east-west. Localised strandline deposits were also intersected by close-spaced AC drilling.

Airborne geophysical surveys in 2021 improved the definition of the strandline deposits. The GET 2022 now includes four sheet-style horizons and eight strandlines. The revised mineralised horizons were defined by a 0.8% THM cut-off grade as before. Interpretations within adjacent areas that utilised downhole gamma logging were used to estimate the north-south and east-west extents of the Exploration Target.

The strandlines are typically finer grained to the west of the Goschen deposit and become coarser towards the east. The inclusion of the new Company exploration data and that of the verified pre-VHM historical exploration data has enabled a significant extension of the sheet-style system. The MA in the GET 2022 is limited to valuable heavy minerals, monazite, and xenotime.

VHM elected to use OK to estimate a base block model, which was then factored to derive the lower and upper ranges of tonnes and grades in the GET 2022.

Table 18: GET 2022

Tonnage		THM grade		In situ THM	
Low Case	Upper Case	Low Case	Upper Case	Low Case	Upper Case
2,622 Mt	4,071 Mt	2.05%	2.16%	54 Mt	88 Mt
In situ THM		Zircon grade		In situ zircon	
Low Case	Upper Case	Low Case	Upper Case	Low Case	Upper Case
54 Mt	88 Mt	5.31%	6.03%	3 Mt	5 Mt
In situ THM		Rutile grade		In situ rutile	
Low Case	Upper Case	Low Case	Upper Case	Low Case	Upper Case
54 Mt	88 Mt	2.03%	2.34%	1 Mt	2 Mt
In situ THM		Leucoxene grade		In situ leucoxene	
Low Case	Upper Case	Low Case	Upper Case	Low Case	Upper Case
54 Mt	88 Mt	3.08%	3.46%	2 Mt	3 Mt
In situ THM		Ilmenite grade		In situ ilmenite	
Low Case	Upper Case	Low Case	Upper Case	Low Case	Upper Case
54 Mt	88 Mt	7.13%	8.2%	4 Mt	7 Mt
In situ THM		Monazite grade		In situ monazite	
Low Case	Upper Case	Low Case	Upper Case	Low Case	Upper Case
54 Mt	88 Mt	0.68%	0.76%	0.4 Mt	0.7 Mt
In situ THM		Xenotime grade		In situ xenotime	
Low Case	Upper Case	Low Case	Upper Case	Low Case	Upper Case
54 Mt	88 Mt	0.07%	0.07%	0.04 Mt	6. Mt

21. Legal

21.1 Royalties

Under the Victorian royalties regime, the holder of a mining licence must pay royalties in accordance with the rate or method of assessment and at the times specified in the licence. As such, royalties will be payable by the Company for any commodities to be produced from the proposed operation at the Project, noting first production is targeted in 2025.

Pursuant to the Mineral Resources (Sustainable Development) (Mineral Industries) Amendment Regulations 2019 (Regulations) as at the date of the Prospectus, royalties for any mineral (other than gold or lignite) are payable at the rate of 2.75% of the net market value of the mineral produced under a mining licence. In addition, royalties are payable at the rate of \$1.43 per cubic metre for tailings resulting from work under a licence over Crown land disposed of by the holder of a mining licence. The royalty rates are reviewed on an ad hoc basis by the Victorian Government, with the last variation in rates introduced in January 2020.

If the Company's gold exploration activities are successful, the Company may be subject to further royalties in the future.

For all minerals (other than gold), the royalty return must be submitted once a year. The failure of a licence holder to pay royalties and/or submit royalty returns may result in the issue of penalties under the Regulations. The information provided in respect of royalty returns is used to monitor compliance obligations, including expenditure and the status of the site.

21.2 Material Contracts

21.2.1 Offtakes

VHM has entered a MOU with Shenghe in respect of the take-or-pay offtake arrangements for the Goschen Project Phase 1 products as summarised in the Prospectus. VHM advises that the parties are continuing the detailed contract negotiations. Accordingly, as disclosed on 28 February 2023 and as contemplated in the MOU, the parties have agreed to extend the target date by which the formal agreement is to be finalised by 30 April 2023. There is no guarantee that formal agreement will be reached by this date, or at all.

VHM has developed a robust and forward-looking offtake strategy involving three broad phases as outlined in Figure 23 below. VHM is implementing this strategy with the ultimate objective of selling REO including high-value neodymium and praseodymium oxide.

Considering that China currently holds the overwhelming share of critical minerals processing capacity, with the only processing plants outside of China based in Estonia (owned by Neo Performance Materials) and Malaysia (owned by Lynas Rare Earths), any rare earth processing in the near-term will unavoidably be undertaken in China.

VHM is seeking to achieve the ultimate objective of its offtake strategy by aligning with its phased production development, the development of processing capacity globally, and the Australian Government's Critical Minerals Strategy.

Figure 23: Offtake strategy summary



Near-term

- Key objective of the near-term phase is to secure an offtake partner that:
 - **Globally recognised:** Is globally recognised as a leader in the processing of rare earth mineral concentrates (REMC) and mixed rare earth carbonates (MREC);
 - **Capacity:** Has the capacity to absorb a material volume of the production offtake from Phase 1 and Phase 1A; and
 - **Funding support:** May have an interest in providing additional funding, by way of an equity investment into VHM to facilitate and accelerate its own production development to Phase 2 and Phase 3.
- Based on the key objectives of this Early-Phase strategy and in light of the very limited processing capacity and capability outside of China, VHM has determined the most suitable offtake partner for the Project to be Shenghe Resources.



Medium-term

- VHM's Mid-term offtake strategy will see the unique development of dual supply chains.
- Will include the commencement of offtake into:
 - European and US markets (both ally countries to Australia), whilst;
 - Also continuing to supply to China-based customers, most notably Shenghe.
- The maturing of the Offtake Strategy through this Mid-term Phase aligns with VHM's phased development, such that as the Company progresses towards producing a combination of MREC and premium zircon and titania products, its universe of potential buyers expands.



Long-term

- The Long-term Phase will see the completion of the phased production development, most notably the construction of the Australian Rare Earth Mineral (AREM) Refinery Project.
- The AREM will facilitate the production of rare earth oxides locally in Australia, such as neodymium, praseodymium, and terbium, which are used in the production of high-strength permanent magnets.
 - These permanent magnets are critical components of numerous products across a wide range of applications.
- **Critical Minerals Strategic Alignment:** The production of such rare earth oxides in Australia means that VHM's products can be sold to a multitude of end users and Australia's overseas geopolitical allies.
- This places the Company in the rare position of having multiple supply chains and therefore, being able to optimise and diversify its offtake into (i) the United States, (ii) Europe, as well as (iii) supplying companies domiciled locally in Australia.

The phased development of VHM's offtake strategy complements and supports the phased production development of the Project.

As the Company progresses further down the value-chain, the extent of potential off-takers will expand. Whereas it may be limited in the early phase to China-based processors, such offtake does signal to the market that VHM's products are of superior quality, and in doing so, allows the Company to cross the bridge to the Mid-term Phase of its offtake strategy.

21.2.2 Land Access and Purchase Agreements

The Land Access Agreements are on standard commercial terms, and pertinently are sufficient (in terms of geographic coverage and subject matter) to cover the Company's current activities. The identity of the counterparties is otherwise not material to investors and subject to obligations of confidentiality.

VHM group companies have entered into three land acquisition agreements (with a fourth expected in the H1 CY 2023) with regional landowners, to purchase the freehold title to all land within the proposed operational footprint of the Goschen Project. Once the fourth agreement is entered into, no further land is required or intended for the Goschen Project as the mine footprint will be 100% secured under land purchase agreements.

The three existing land acquisition contracts create legally binding commitments for the vendors to sell the subject land but have long dated settlement dates with flexibility for the Company to control timing of settlement up to agreed end dates (being January 2026 or December 2030). The Company does not intend to complete any of these land acquisition contracts until the land is needed; and for community engagement purposes, would prefer agricultural use of the land continue under the current owners until such time as acquisition of the land is required for mining purposes.

The foregoing arrangements satisfy regulatory requirements with respect to entering into access agreements with affected landowners and address operational requirements during the construction and operational phases of the Goschen Project. Further detail in respect of the foregoing agreements is set out in the Company's Prospectus.

In addition, VHM has land access agreements with numerous private landholders for exploration activities. These agreements meet the requirements of the MRSDA in terms of entering into access agreements with relevant landholders.

22. Risks

Following a risk assessment, the residual risk profile was almost entirely in the low to medium range and no extreme risks were identified.

The key focus of the risk assessment was on those risks deemed to be 'material' to the delivery of the Project. The numerous low-order risks associated with project execution will be addressed within detailed project risk assessments during the execution phase.

There are no individual risks ranked with a score of higher than 13.

Table 19: Summary of residual high and medium risks (ranking ≥ 12)

Risk number	RBS element	Threat/concern	Risk ranking
7	Mining	In-pit instability of deposited tailings materials may occur	12
14	Processing	Processing plant throughput may be less than DFS	13
15	Processing	Processing plant recovery may be below the level defined within the DFS	13
21	Tailings	Tailings deposition / water recovery may not be as predicted	13
22	Tailings	Backfilled tailings material in mined pits may not perform as predicted	13
38	Permits approvals	EES timelines and potential decision-making process)	13
43	HSE	Rare earth metal concentrate (REMC) may not be appropriately contained at the operating site	12
54	Financial funding	Project costs estimate may be exceeded	13
56	Financial funding	Ability to raise project finance for capital costs	13

The Consequence and Likelihood ratings in Table 20 below were used to score the Risk Rankings for the Project.

Table 20: Consequence and likelihood ratings matrix

Consequence of Event	Likelihood or Probability of Event				
	Rare	Unlikely	Possible	Likely	Almost Certain
Critical	M11	M16	H20	E24	E25
Major	L7	M12	H18	H21	E23
Moderate	L4	M10	M13	H19	H22
Minor	L2	L5	M9	M14	M17
Insignificant	L1	L3	L6	L8	M15

23. Future Works

23.1 Phase 1

The Company anticipates appointing Mineral Technologies in Q1 2023 to deliver Detailed Design Part 1 which will progress the engineering design to deliver a target cost estimate for the EPC supply of the Phase 1 process plant prior to the FID.

The following deliverables will be produced as part of Detailed Design Part 1 and a subsequent Part 2 will be required for plant construction. Table 21 has been included as a summary to demonstrate the intent for each of the forthcoming phases of design.

Table 21: Future works program for Phase 1

Phase	Intent	Deliverables
Detailed Design Part 1	To progress engineering design to a sufficient level to support the development of a target cost estimate for the EPC supply of the process plant	Target cost estimate for ECP supply of phase 1 process plant Delivery schedule for phase 1 process plant Preferred vendors included in mechanical equipment list selected from tender bid evaluations
Detailed Design Part 2	Progress detailed engineering required for plant construction	Detailed engineering required for the plant to be constructed

23.2 Phase 1A

The hydromet engineering study will serve to bring up the level of planning, design, understanding and integration of the hydromet circuit and in line with the development level of the remaining facility. The Project will include key activities across a two-stage approach that has been carefully designed to ensure success. The first stage focuses on the study phase, including an engineering study to develop the design and definition to enable a cost accuracy increase from circa $\pm 35\%$ to $\pm 15\%$ for both capital and opex, and a FEED study to develop design and definition that will further enable a cost accuracy increase from circa $\pm 15\%$ to $\pm 5-10\%$ for both capital and opex and implementation planning. While the second stage focuses on implementation, including project management and controls, detailed design, procurement and logistics, construction, and commissioning.

24. DFS Contributors

The DFS incorporates and expands on work already carried out by VHM, with several independent consultants with national and international experience contributing to its delivery. VHM appreciates and acknowledges their significant contributions to this body of work.

Table 22: DFS contributors

Contributor	Area
Adamas Intelligence	Rare earth product pricing and market analysis
AECOM	Environmental and community, power and water supply, closure, and rehabilitation
ANSTO	Metallurgical testwork for hydromet circuit
ATC Williams	AT and Strategy
Auralia	Reserve estimate, mine design and planning
BDO Australia	Remuneration
CDM Smith	Hydrogeology
CSA Global	Independent technical assessment report (ITAR)
Eco-Logical Australia	Cultural and heritage
GPA Engineering	Hydromet Circuit engineering and study work
JRHC Enterprises	Radiation
Mapien	Human resources
Mineral Technologies	Testwork and process design engineering
Nature Advisory	Flora and native vegetation assessment
pitt&sherry	Geotechnical engineering and tailings management
Qube Holdings	Product Transport and Logistics
Right Solutions Australia	Geology and mineral resource, geochemistry, tenement management
RMCG	Water supply
SciDev	Tailings treatment
SLR	Air quality assessment
TZMI	Metallurgical and process management testwork, market analysis
Water Technology	Hydrology

25. Glossary of Terms

Table 23: Glossary of terms

Acronym	Term
AACE	Advancement of Cost Engineering
AC	Aircore
AEP	Annual Exceedance Probability
AusIMM	Australasian Institute of Mining and Metallurgy
Capex	Capital Costs
CAGR	Compound Annual Growth Rate
CBR	California Bearing Ratio
CSEP	Community and Stakeholder Engagement Plan
DD	Detailed Design
DFS	Definitive Feasibility Study
DTP	Department of Transport and Planning
EBITDAX	Earnings Before Interest, Taxes, Depreciation, Amortization and Exploration
EES	Environmental Effects Statement
EE Act	Environment Effects Act 1978 (Victoria)
EL	Exploration Licence
EPA	Environment Protection Authority
EPBC Act	Environment Protection Biodiversity Conservation Act 1999 (Commonwealth)
EPC	Engineering, Procurement and Construction
FOB	Free On Board
FOREX	Foreign Exchange
FCF	Free Cash Flow
FEED	Front-end Engineering and Design
FPP	Feed Preparation Plant
Gl/a	Gigalitres Per Annum
GST	Goods and Services Tax

Ha	Hectare
HAL	Hot Acid Leach
HLS	Heavy Liquid Separation
HMC	Heavy Mineral Concentrate
HTR	High Tension Roll
IAC	Inquiry and Advisory Committee
IDW ²	Inverse Distance Weighting Squared
IRR	Internal Rate of Return
JORC	Joint Ore Reserves Committee
LoM	Life-of-Mine
LiDAR	Light Detection and Ranging
LIMS	Low Intensity Magnetic Separator
LNG	Liquefied Natural Gas
MA	Mineral Assemblage
m/s	Metres per second
Mt	Million Tonnes
Mtpa	Million Tonnes Per Annum
MOU	Memorandum/s of Understanding
MSP	Mineral Separation Plant
MREC	Mixed Rare Earth Carbonate
MRSDA	Mineral Resources Sustainable Development Act
MUP	Mining Unit Plant
NdFeB	Neodymium-iron-boron
NPI	Non-process Infrastructure
NPV	Net Present Value
OK	Ordinary Kriging
OPEX	Operating Costs
PFS	Pre-Feasibility Study
PLC	Programmable Logic Controller

The Project	Goschen Mineral Sands and Rare Earths Project
PSA	Planning Scheme Amendment
QEMSCAN	Quantitative Evaluation of Minerals by Scanning Electron Microscopy
RE	Rare Earth
REE	Rare Earth Element
REM	Rare Earth Minerals
REMC	Rare Earth Mineral Concentrate
REMFC	Rare Earth Mineral Flotation Circuit
REO	Rare Earth Oxides
RER	Rare Earth Roll
RL	Retention Lease
RoM	Run of Mine
SG	Specific Gravity
SL	Slimes
SPT	Standard Penetration Test
THM	Total Heavy Minerals
TREO	Total Rare Earth Oxide
TRG	Technical Reference Group
TSF	Tailings Storage Facility
TSPP	Tetrasodium Pyrophosphate
UIX	Uranium Ion Exchange
VHM or the Company	VHM Limited
WCP	Wet Concentrator Plant
WHIMS	Wet High Intensity Magnetic Separators
WWTP	Wastewater Treatment Plant
XRF	X-ray Fluorescence

Relevant Information regarding DFS Refresh Preparation

The DFS Refresh referred to in this announcement is based on the Mineral Resource and Ore Reserve as released in the Prospectus.

The pricing for commodities used in the DFS Refresh was based on independent market research and the economic analysis results should be treated as preliminary in nature and caution should be exercised in their use as a basis for assessing project feasibility.

Market analysis was commissioned and delivered during Q1 2023 by Adamas Intelligence for the rare earth market and TZ Minerals International Pty Ltd (TZMI) for the titanium mineral and zircon markets.

Production Target

The information in this announcement regarding the Production Target, and forecast financial information derived from that Production Target, was set out in the Prospectus. The Company confirms that all material assumptions underpinning the Production Target and the forecast financial information derived from that Production Target continue to apply and have not materially changed, except to the extent set out in the DFS Refresh with respect to the forecast financial information.

Competent Person's Statement

The information in this announcement that relates to JORC estimates of Mineral Resources was first reported in the Prospectus. The Company confirms that it is not aware of any new information or data that materially affects the Mineral Resource previously reported. The Company confirms that the form and context in which the Competent Persons' findings are presented have not been materially modified.

Forward Looking Statement

This document may contain certain forward-looking statements concerning VHM Limited. Forward-looking statements are not statements of historical fact and actual events, and results may differ materially from those described in the forward-looking statements as a result of a variety of risks, uncertainties, and other factors. Forward-looking statements are inherently subject to business, economic, competitive, political, and social uncertainties, and contingencies. Many factors could cause the Company's actual results to differ materially from those expressed or implied in any forward-looking information provided by the Company, or on behalf of, the Company. Such factors include, among other things, risks relating to additional funding requirements, metal prices, exploration, development and operating risks, competition, production risks, regulatory restrictions, including environmental regulation and liability and potential title disputes.

Forward-looking statements in this document are based on the company's beliefs, opinions and estimates of VHM Limited as of the dates the forward-looking statements are made, and no obligation is assumed to update forward looking statements if these beliefs, opinions, and estimates should change or to reflect other future developments.

ENDS

This announcement has been approved by the Board of VHM.

For Further Information Contact:

Carly O'Regan
General Manager, Investor Relations
M: +61 (0)431 068 814
E: carly.oregan@vhmltd.com.au

Ian Hobson
Company Secretary
M: +61 (0)407 421 185
E: ian.hobson@vhmltd.com.au

Media

James Strong
Citadel-MAGNUS
M: +61 448 881 174
E: jstrong@citadelmagnus.com

Appendix A: JORC Ore Reserves

Table 1: Company Ore Reserves

Area	Date	Classification	Ore	THM	Zircon	Rutile	Leucoxene	Ilmenite	Monazite	Xenotime
			(Mt)	(%)	(%)	(%)	(%)	(%)	(%)	(%)
Area 1	Mar-21	Proved	24.5	5.4	29.9	10.8	9.0	24.7	4.3	0.8
Area 1	Mar-21	Probable	14.6	3.2	29.2	11.7	9.2	25.5	4.5	0.9
Area 3	Feb-21	Probable	159.6	3.5	20.3	9.4	8.1	25.8	3.4	0.6
Total		Proved	24.5	5.4	29.9	10.8	9.0	24.7	4.3	0.8
		Probable	174.2	3.5	21.0	9.6	8.2	25.8	3.5	0.6
Grand Total			198.7	3.7	21.7	9.7	8.2	25.7	3.5	0.6

Area	Date	Classification	CeO ₂	Dy ₂ O ₃	Er ₂ O ₃	Eu ₂ O ₃	Gd ₂ O ₃	La ₂ O ₃	Nd ₂ O ₃	Pr ₆ O ₁₁	Sm ₂ O ₃	Tb ₄ O ₇	Tm ₂ O ₃	Y ₂ O ₃	Yb ₂ O ₃	TREO
			(%)	(%)	(%)	(%)	(%)	(%)	(%)	(%)	(%)	(%)	(%)	(%)	(%)	(%)
Area 1	Mar-21	Proved	0.960	0.070	0.050	0.004	0.060	0.480	0.380	0.110	0.070	0.012	0.008	0.470	0.050	2.720
Area 1	Mar-21	Probable	0.971	0.067	0.047	0.004	0.060	0.468	0.400	0.108	0.072	0.011	0.007	0.458	0.050	2.721
Area 3	Feb-21	Probable	0.805	0.057	0.039	0.003	0.056	0.378	0.339	0.093	0.064	0.009	0.006	0.386	0.040	2.297
Total		Proved	0.960	0.070	0.050	0.004	0.060	0.480	0.380	0.110	0.070	0.012	0.008	0.470	0.050	2.720
		Probable	0.817	0.058	0.039	0.003	0.056	0.385	0.344	0.094	0.065	0.009	0.006	0.391	0.041	2.328
Grand Total			0.844	0.060	0.041	0.003	0.057	0.402	0.351	0.097	0.066	0.010	0.006	0.406	0.043	2.401

Table 2: Goschen DFS Ore Reserves subset of global Company Ore Reserves

Area	Date	Classification	Ore	THM	Zircon	Rutile	Leucoxene	Ilmenite	Monazite	Xenotime
			(Mt)	(%)	(%)	(%)	(%)	(%)	(%)	(%)
Area 1	Mar-21	Proved	25.5	5.6	29.6	10.8	9.1	24.7	4.3	0.8
Area 1	Mar-21	Probable	7.6	2.2	27.6	12.7	10.5	25.9	4.3	0.9
Area 3	Feb-21	Probable	65.7	3.6	19.7	9.1	7.9	25.3	3.3	0.6
Total		Proved	25.5	5.6	29.6	10.8	9.1	24.7	4.3	0.8
		Probable	73.3	3.4	20.2	9.3	8.1	25.4	3.4	0.6
Grand Total			98.8	4.0	23.6	9.9	8.5	25.1	3.7	0.7

Area	Date	Classification	CeO ₂	Dy ₂ O ₃	Er ₂ O ₃	Eu ₂ O ₃	Gd ₂ O ₃	La ₂ O ₃	Nd ₂ O ₃	Pr ₆ O ₁₁	Sm ₂ O ₃	Tb ₄ O ₇	Tm ₂ O ₃	Y ₂ O ₃	Yb ₂ O ₃	TREO
			(%)	(%)	(%)	(%)	(%)	(%)	(%)	(%)	(%)	(%)	(%)	(%)	(%)	(%)
Area 1	Mar-21	Proved	0.960	0.070	0.050	0.004	0.060	0.480	0.380	0.110	0.070	0.012	0.008	0.470	0.050	2.720
Area 1	Mar-21	Probable	0.957	0.065	0.045	0.003	0.059	0.454	0.398	0.104	0.071	0.012	0.007	0.456	0.050	2.682
Area 3	Feb-21	Probable	0.795	0.056	0.038	0.003	0.055	0.373	0.335	0.091	0.063	0.009	0.006	0.383	0.039	2.271
Total		Proved	0.960	0.070	0.050	0.004	0.060	0.480	0.380	0.110	0.070	0.012	0.008	0.470	0.050	2.720
		Probable	0.806	0.056	0.039	0.003	0.055	0.379	0.339	0.092	0.064	0.009	0.006	0.388	0.040	2.298
Grand Total			0.862	0.061	0.043	0.003	0.057	0.415	0.354	0.099	0.066	0.010	0.007	0.417	0.044	2.451

Competent Person Statement: The information in this announcement that relates to the Company's Ore Reserves are based on information collated and evaluated by, and fairly represents information and supporting documentation compiled by Anthony Keers who is a member of the Australasian Institute of Mining and Metallurgy and has sufficient experience which is relevant to the style of mineralisation and type of deposit under consideration and to the activity which he has undertaken to qualify as a Competent Person as defined in the JORC Code. Mr Keers is a full-time employee of Auralia Mining Consulting Pty Ltd. Mr Keers consents to the inclusion in this announcement of the matters based on his information in the form and context in which it appears.

Accompanying JORC Tables can be found at Appendix D of this Announcement.

Appendix B: Area 1 – JORC Table 1 (JORC Code, 2012 Edition)

Competent Person:	Graham Howard (JORC Table 1 Sections 1, 2, 3)
Report Title:	Area 1 Mineral Resource Estimate Report
Report Reference:	RPP780
Date Reported:	29 November 2020

Section 1: Sampling Techniques and Data

(Criteria in this section apply to all succeeding sections)

Criteria	JORC Code Explanation	Commentary
Sampling techniques	<p><i>Nature and quality of sampling (e.g. cut channels, random chips, or specific specialised industry standard measurement tools appropriate to the minerals under investigation, such as down hole gamma sondes, or handheld XRF instruments, etc.). These examples should not be taken as limiting the broad meaning of sampling. Include reference to measures taken to ensure sample representivity and the appropriate calibration of any measurement tools or systems used. Aspects of the determination of mineralisation that are Material to the Public Report.</i></p> <p><i>In cases where 'industry standard' work has been done this would be relatively simple (e.g. 'reverse circulation drilling was used to obtain 1 m samples from which 3 kg was pulverised to produce a 30 g charge for fire assay'). In other cases more explanation may be required, such as where there is coarse gold that has inherent sampling problems. Unusual commodities or mineralisation types (e.g. submarine nodules) may warrant disclosure of detailed information.</i></p>	<p>Aircore (AC) drilling was used to obtain samples at 1 m intervals. The following information covers the sampling process:</p> <ul style="list-style-type: none"> • The full 1 m drill samples were split down to approximately ~1,000 g to ~2,500 g by rotary splitter mounted on the drilling rig. • Each 1 m composite subsample was homogenised by manually mixing the sample within the sample bag. • Bulk sample reject for each metre was retained. The 2018 bulk rejects were included in the Area 1 metallurgy sampling program. • A sample of sand of approximately 20 g is scooped from the sample bag for visual estimation of heavy mineral and slimes content and sample description. The same mass of sample is consistently used for each panned sample to ensure calibration is maintained for consistency in visual estimation. • Sample logging software is used at the drill rig for recording sample intervals and descriptions. • The sample bag is sealed and dispatched to a commercial laboratory for analysis. • The laboratory sample was oven dried at 105°C for a minimum of 2 hours (and then re-dried for up to 12 hours if required), and split down to 100 g subsamples via a rotating splitter fed by a vibrating screen. A laboratory repeat was taken at ~1:25 samples. • All drillhole subsamples were screened using vibrating screens with a top screen of either 1 mm or 2 mm mesh and a bottom screen of either 20 µm or 38 µm. Oversize (+1 mm or 2 mm fraction) was removed and the -20 µm or -38 µm fraction (SLIMES) discarded. The sand fraction (1 mm or 2 mm to +20 µm or 38 µm) was then submitted for heavy liquid separation (HLS) using TBE to determine total heavy mineral (THM) content. Samples screened at the bottom screen of 20 micron at ALS Laboratories employed the use of a centrifuge-assisted separation. All other HLS samples used static-fall gravity separation. • Duplicates were taken at the drill rig by hanging sample bags side-by-side on the rotary splitter at a rate of ~1:20. • Duplicates were taken within mineralisation zones as the waste material was excluded from sampling. • Commercially obtained standards were inserted by the laboratory at a rate of ~1:40.

Criteria	JORC Code Explanation	Commentary
Drilling techniques	<i>Drill type (e.g. core, reverse circulation, open-hole hammer, rotary air blast, auger, Bangka, sonic, etc) and details (e.g. core diameter, triple or standard tube, depth of diamond tails, face-sampling bit, or other type, whether core is oriented and if so, by what method, etc.).</i>	<p>Wallis Drilling was the contractor used for the 2017 and 2018 AC drilling and sampling program upon which the Goschen Area 1 Mineral Resource estimate (MRE) was based.</p> <p>AC drilling, which is a standard technique for the heavy mineral sand industry, was used. AC drilling is a form of reverse circulation drilling where the sample is collected at the face and returned inside the inner tube.</p> <p>All drillholes were vertical and were drilled using NQ-sized drill string and bits. Drill rods were 3 m long.</p>
Drill sample recovery	<p><i>Method of recording and assessing core and chip sample recoveries and results assessed.</i></p> <p><i>Measures taken to maximise sample recovery and ensure representative nature of the samples.</i></p> <p><i>Whether a relationship exists between sample recovery and grade and whether sample bias may have occurred due to preferential loss/gain of fine/coarse material.</i></p>	<p>Drill sample recovery is monitored by recording sample condition from “dry good” to “wet poor”.</p> <p>While initially collaring the hole, limited sample recovery can occur in the initial 0–1 m sample interval owing to sample and air loss into the surrounding loose soil. The initial 0–1 m sample interval is drilled very slowly to achieve optimum sample recovery.</p> <p>Each entire 1 m sample apart from the subsample taken for logging and analysis) is collected at the drill rig in large, numbered plastic bags for dispatch to the initial split preparation facility.</p> <p>At the end of each drill rod, the drill string is cleaned by blowing down with air to remove any clay and silt potentially built up in the sample tubes.</p> <p>The twin-tube AC drilling technique is known to provide high-quality samples from the face of the drillhole (in ideal conditions).</p>
Logging	<p><i>Whether core and chip samples have been geologically and geotechnically logged to a level of detail to support appropriate Mineral Resource estimation, mining studies and metallurgical studies.</i></p> <p><i>Whether logging is qualitative or quantitative in nature. Core (or costean, channel, etc) photography.</i></p> <p><i>The total length and percentage of the relevant intersections logged.</i></p>	<p>Each AC sample was qualitatively logged into a field-validated data capture software package, and later uploaded to the AcQuire database.</p> <p>The samples were logged for lithology, colour, grain size, sorting, hardness, sample condition, washability, estimated heavy mineral content, estimated slimes content and any relevant comments such as slope, vegetation, or cultural activity.</p> <p>Every drillhole was logged in full.</p> <p>Logging is undertaken with reference to a Drilling Guideline with codes prescribed and guidance on description to ensure consistent and systematic data collection.</p> <p>Downhole gamma probe logging was completed in 2018 program. This technique provided spatial indication of valuable heavy minerals (VHM) mineral concentrations based on occurrence of radioactive minerals associated with VHM deposits.</p>
Subsampling techniques and sample preparation	<p><i>If core, whether cut or sawn and whether quarter, half or all core taken.</i></p> <p><i>If non-core, whether riffled, tube sampled, rotary split, etc and whether sampled wet or dry.</i></p> <p><i>For all sample types, the nature, quality, and appropriateness of the sample preparation technique.</i></p> <p><i>Quality control procedures adopted for all subsampling stages to maximise representivity of samples.</i></p>	<p>The 1 m sample interval is rotary split at the drill rig. A total of ~1.2 kg to ~2.5 kg of each sample was placed into calico sample bags and exported to either Diamantina or ALS Laboratory for THM analysis.</p> <p>The water table depth, if intersected, was noted in all geological logs and when water injection was required to aid sample recovery the sample was logged as “wet poor”.</p> <p>Almost all the samples are silty sand, sand, sandy clay, clayey sand, or clay and this sample preparation method is considered appropriate.</p> <p>The sample sizes were deemed suitable to reliably capture THM, slime, and oversize characteristics, based on industry experience of the geologists involved and consultation with laboratory staff.</p>

Criteria	JORC Code Explanation	Commentary
	<p><i>Measures taken to ensure that the sampling is representative of the in-situ material collected, including for instance results for field duplicate/second-half sampling.</i></p> <p><i>Whether sample sizes are appropriate to the grain size of the material being sampled.</i></p>	<p>Field duplicates of the samples were completed at a frequency of 1:20 primary samples.</p> <p>Bulk sample rejects (5–8 kg) retained for further testwork.</p>
<p>Quality of assay data and laboratory tests</p>	<p><i>The nature, quality and appropriateness of the assaying and laboratory procedures used and whether the technique is considered partial or total.</i></p> <p><i>For geophysical tools, spectrometers, handheld XRF instruments, etc, the parameters used in determining the analysis including instrument make and model, reading times, calibrations factors applied and their derivation, etc.</i></p> <p><i>Nature of quality control procedures adopted (e.g. standards, blanks, duplicates, external laboratory checks) and whether acceptable levels of accuracy (i.e. lack of bias) and precision have been established.</i></p>	<p>Both the 2017 and 2018 programs undertook the following sample logging process:</p> <ul style="list-style-type: none"> • The wet panning at the drill site provides an estimate of the THM % which is sufficient for the purpose of determining approximate concentrations of THM in the first instance. <p>AC sample:</p> <ul style="list-style-type: none"> • The individual 1 m AC subsamples were assayed by either Diamantina Laboratories or ALS Global in Perth, Western Australia. Samples were initially oven dried at 105°C for two hours (and then up to 12 hours for very wet samples) then reduced on a rotary splitter by 15%. Samples were then riffle split to 100 g sub-splits (weighed and captured) and then left to soak overnight. • All samples were then wet washed and sieved on vibrating screens using a top screen of +1 mm or +2 mm to remove the very coarse sand, pebbles, or grits. The bottom screen used either a 20 µm or 38 µm mesh for removal and determination of the -SLIMES fraction. The remaining sand fraction was then submitted to HLS process using either centrifuge assisted separation (ALS-20 micron), or static-gravity drop. (Diamantina – all). • The laboratories used TBE as the heavy liquid medium – with density range between 2.92 g/ml and 2.96 g/ml. The density of the heavy liquid was checked every day. • This is an industry standard technique. • Field duplicates of the samples were collected and submitted for assay at a frequency of 1 per 20 primary samples. • Both laboratories completed their own internal quality assurance and quality control (QAQC) checks that included laboratory standards every 40th sample and a Laboratory repeat every 25th sample prior to the results being released. • Analysis of QAQC samples show the laboratory data to be of acceptable accuracy and precision. • The adopted QAQC protocols are acceptable for this stage of test work. • Assay methodology research and development was completed in parallel using samples from various areas of the Goschen deposit using different THM assaying and mineral assemblage analytical methods. This included round robin submissions to different assay laboratories. Testwork included analysis of different analytical methods to determine appropriate THM analytical method.
<p>Verification of sampling and assaying</p>	<p><i>The verification of significant intersections by either independent or alternative company personnel.</i></p> <p><i>The use of twinned holes.</i></p>	<p>All results were checked by the Company's Geology Manager.</p> <p>The Company's Geology Manager and an independent Resource Geologist made periodic visits to the laboratories to observe sample processing and procedure.</p>

Criteria	JORC Code Explanation	Commentary
	<p><i>Documentation of primary data, data entry procedures, data verification, data storage (physical and electronic) protocols.</i></p> <p><i>Discuss any adjustment to assay data.</i></p>	<p>A process of laboratory data validation using mass balance is undertaken to identify entry errors or questionable data.</p> <p>Field and laboratory duplicate data pairs (THM/OS/SLIME) of each batch are plotted to identify potential quality control issues.</p> <p>Standard Reference Material sample results are checked from each sample batch to ensure they are within tolerance (<3SD) and that there is no bias.</p> <p>The field and laboratory data were exported from the VHM Limited (VHML) AcQuire database and imported into Datamine by a geologist contracted to VHML, which is appropriate for this stage in the program. Data validation criteria are included to check for overlapping sample intervals, end of hole match between "Lithology", "Sample", "Survey" files and other common errors.</p>
Location of data points	<p><i>Accuracy and quality of surveys used to locate drillholes (collar and downhole surveys), trenches, mine workings and other locations used in Mineral Resource estimation.</i></p> <p><i>Specification of the grid system used.</i></p> <p><i>Quality and adequacy of topographic control.</i></p>	<p>Drillhole collar locations were surveyed by an independent surveyor using industry standard equipment. Three permanent survey marks in the area provided survey control, allowing for repeatable and accurate survey readings across the project area.</p> <p>The datum used is GDA 94 and coordinates are projected as MGA Zone 54.</p> <p>A digital topographic surface was generated by VHML from data collected during a light detection and ranging (LiDAR) survey commissioned by VHML. The accuracy of the locations is sufficient for this stage of exploration.</p>
Data spacing and distribution	<p><i>Data spacing for reporting of Exploration Results.</i></p> <p><i>Whether the data spacing, and distribution is sufficient to establish the degree of geological and grade continuity appropriate for the Mineral Resource and Ore Reserve estimation procedure(s) and classifications applied.</i></p> <p><i>Whether sample compositing has been applied.</i></p>	<p>454 drillholes were used to inform the resource estimate. All holes were completed in drilling campaigns conducted in 2018 or 2019. Drillholes are spaced on a grid of lines spaced at 200 m in the north-south direction and typically between 100 m and 200 m in the east-west direction with some close-spaced drilling as close as 50 m along traverses.</p> <p>The collar spacing is sufficient to provide a high degree of confidence in geological model and grade continuity within the holes at this stage.</p> <p>Each AC drill sample is a single 1 m sample of sediment intersected down the hole. 16,446 samples were used to inform the MRE.</p> <p>No downhole compositing has been applied to models for values of THM, slime, and oversize.</p> <p>Compositing of samples was undertaken on THM concentrates for mineral assemblage determination. Composite samples were determined by geological domains.</p>
Orientation of data in relation to geological structure	<p><i>Whether the orientation of sampling achieves unbiased sampling of possible structures and the extent to which this is known, considering the deposit type.</i></p> <p><i>If the relationship between the drilling orientation and the orientation of key mineralised structures is considered to have introduced a sampling bias, this should be assessed and reported if material.</i></p>	<p>The mineralisation at the Goschen Area 1 project is a largely flat-lying (with some soft sediment deformation across a basement fault) sedimentary package which does not display a strong orientation of mineralisation at the current sample spacing.</p>
Sample security	<p><i>The measures taken to ensure sample security.</i></p>	<p>AC samples were stored on site (at a dedicated warehouse in Kerang).</p>

Criteria	JORC Code Explanation	Commentary
		<p>The samples were then dispatched to Perth using Swan Hill Freight agents and delivered directly to the laboratories.</p> <p>The laboratory inspected the packages and did not report tampering of the samples</p>
Audits or reviews	<i>The results of any audits or reviews of sampling techniques and data.</i>	Internal reviews were undertaken during the geological interpretation and throughout the modelling process.

Section 2: Reporting of Exploration Results

(Criteria listed in the preceding section also apply to this section)

Criteria	JORC Code Explanation	Commentary
Mineral tenement and land tenure status	<p><i>Type, reference name/number, location and ownership including agreements or material issues with third parties such as joint ventures, partnerships, overriding royalties, native title interests, historical sites, wilderness or national park and environmental settings.</i></p> <p><i>The security of the tenure held at the time of reporting along with any known impediments to obtaining a licence to operate in the area.</i></p>	<p>The exploration work was completed on tenements that are 100% owned by VHML in Victoria, Australia.</p> <p>The drill samples for this MRE were drilled and collected from Exploration Licence 5520.</p> <p>The Exploration Licence original date of grant was 10 October 2014 with an expiry date of 9 October 2019. A Retention Licence to replace the Exploration Licence was granted by Earth Resources Regulation, which is the responsible statutory body and part of Victorian Department of Jobs, Precincts and Regions, in January 2020.</p>
Exploration done by other parties	<i>Acknowledgment and appraisal of exploration by other parties.</i>	<p>Historical exploration work was completed by previous exploration companies including Austiex (1977–1978), CRA Exploration (1981–1987), Renison Goldfields Consolidated (1980–1991), WJ Holdings (1998), RZM Group (1999), Basin Minerals (2001), Providence Gold and Minerals (2004–2005), and Iluka (2009).</p> <p>The Company has obtained the hardcopy reports and maps in relation to this information as part of its historical review in preparation for their current work program.</p> <p>The historical data comprises surface sampling, limited AC drilling and mapping.</p> <p>The current resource estimate is based solely on work conducted by VHML.</p>
Geology	<i>Deposit type, geological setting, and style of mineralisation.</i>	<p>The heavy mineral sands at the Goschen Project is a fine-grained deposit hosted within the offshore depositional paleo-environment of the Loxton Parilla Sands. The Loxton-Parilla Sand is common within the Murray Basin and hosts all known mineral sand deposits in the Basin. Alluvial sediments of the Shepparton Formation have been deposited over the Loxton-Parilla Sand and the Bookpurnong Formation consisting of shallow marine clays and marls is positioned below within the lithological sequence.</p>
Drill hole information	<p><i>A summary of all information material to the understanding of the exploration results including a tabulation of the following information for all Material drillholes:</i></p> <ul style="list-style-type: none"> • <i>easting and northing of the drillhole collar</i> • <i>elevation or RL (Reduced Level - elevation above sea level in metres) of the drillhole collar</i> • <i>dip and azimuth of the hole</i> • <i>downhole length and interception depth</i> 	<p>Company completed LiDAR survey of the Area 1 Mineral Resource area. All drillholes collar RL adjusted to LiDAR surface.</p> <p>Hole collar surveyed both by global positioning system and surveyor.</p> <p>Holes were vertical.</p> <p>All drillholes were surveyed by downhole gamma probe.</p> <p>Drillhole depth cross verified with drilling reports and geologist log for each hole.</p> <p>The field and laboratory data were exported into the VHML's Acquire database.</p>

Criteria	JORC Code Explanation	Commentary
	<ul style="list-style-type: none"> hole length. <p><i>If the exclusion of this information is justified on the basis that the information is not Material and this exclusion does not detract from the understanding of the report, the Competent Person should clearly explain why this is the case.</i></p>	Drill data verified by light table evaluation during interpretation of 2020 Mineral Resource domains.
Data aggregation methods	<p><i>In reporting Exploration Results, weighting averaging techniques, maximum and/or minimum grade truncations (e.g. cutting of high grades) and cut-off grades are usually Material and should be stated.</i></p> <p><i>Where aggregate intercepts incorporate short lengths of high-grade results and longer lengths of low-grade results, the procedure used for such aggregation should be stated and some typical examples of such aggregations should be shown in detail.</i></p> <p><i>The assumptions used for any reporting of metal equivalent values should be clearly stated.</i></p>	No data aggregation methods were utilised, no top cuts were employed, and all cut-off grades have been reported.
Relationship between mineralisation widths and intercept lengths	<p><i>These relationships are particularly important in the reporting of Exploration Results.</i></p> <p><i>If the geometry of the mineralisation with respect to the drillhole angle is known, its nature should be reported.</i></p> <p><i>If it is not known and only the downhole lengths are reported, there should be a clear statement to this effect (e.g. 'downhole length, true width not known').</i></p>	<p>The nature of the mineralisation is horizontal, thus vertical AC holes represent the true thicknesses of the mineralisation.</p> <p>Downhole widths are reported.</p>
Diagrams	<p><i>Appropriate maps and sections (with scales) and tabulations of intercepts should be included for any significant discovery being reported. These should include, but not be limited to a plan view of drillhole collar locations and appropriate sectional views.</i></p>	Plan view and typical cross sections provided in resource report.
Balanced reporting	<p><i>Where comprehensive reporting of all Exploration Results is not practicable, representative reporting of both low and high grades and/or widths should be practiced to avoid misleading reporting of Exploration Results.</i></p>	Exploration Results have been reported in resource report at THM >1% to indicate a range of potential tonnes and grade
Other substantive exploration data	<p><i>Other exploration data, if meaningful and material, should be reported including (but not limited to): geological observations; geophysical survey results; geochemical survey results; bulk samples – size and method of treatment; metallurgical test results; bulk density, groundwater, geotechnical and rock characteristics; potential deleterious or contaminating substances.</i></p>	Detailed mineral assemblage work was undertaken on composite samples for the Project by ALS Metallurgy Services, Perth and by Bureau Veritas in Adelaide. ALS applied an integrated mineralogical approach using both x-ray fluorescence (XRF) analysis and Quantitative Evaluation of Minerals by Scanning Electron Microscopy (QEMSCAN). Bureau Veritas also use QEMSCAN for mineralogical determinations but use a combination of XRF and laser ablation techniques for chemical assay. These techniques were used to gain a quantitative understanding of the elemental composition and mineralogical assemblage.

Criteria	JORC Code Explanation	Commentary
		<p>The XRF and laser ablation techniques provide measurements of relative elemental abundances (down to limits of a few parts per million) which allows for a quantifiable basis for determination of mineralogy, provenance, depositional environment, and diagenetic history. The XRF analysis was utilised to apply assay data to the geological model for grade interpretation.</p> <p>The QEMSCAN method of analysis required the samples to be screened into +150 µm and -150 µm screen fraction prior to sample preparation and QEMSCAN analysis.</p> <p>Sample preparation required each subsample was mixed with size-graded, high-purity graphite to ensure particle separation and discourage density segregation. These sample-graphite mixtures were then set into moulds using a two-part epoxy resin, producing a representative subsample of randomly orientated particles. Once cured, the resin blocks were then cut to expose a fresh surface which is then gradually ground and polished. Once QAQC checks are completed, the sections are then carbon coated for electron beam conductivity and presented to QEMSCAN for analysis.</p> <p>The samples were analysed using QEMSCAN technology in Field Scan mode and Particle Mineralogical Analysis mode.</p> <p>Detailed sachet scanning of heavy mineral sinks from the drill assay process was carried out to determine regions of gross mineralogy as well as an overall consideration of VHM content. Other considerations undertaken during this sachet logging were the presence of iron oxide coatings on THM, and any gross composition of trash heavy minerals. Sachet logging then had partial input into the geological/mineralogical/THM grade interpretation which then assisted with domain control for modelling, as well as providing guidance for the allocation of mineral assemblage composites where it was not possible to get gamma data due to hole collapse.</p> <p>Early composite samples were generated solely on heavy mineral grades, which were used to generate geological domain boundaries. These composite samples frequently cross later interpretations of domain boundaries. As a result, many of the early composites are not representative of the interpreted mineralised domains. Many of these sample were, therefore, omitted from the dataset used to inform the resource estimate.</p> <p>Once the sample compositing was completed, the sample identification and mineral assemblage composite number was submitted to the labs listed above for mineralogical determination.</p> <p>In mid-2018, a 9.1-tonne bulk sample was created by compositing 429 excess drill sample cuttings (6,843 kg) from the mineralised zones of 107 holes which were drilled in 2018. The bulk of the sample was also complimented with 214 samples (2,238 kg) the mineralised drill-core from 35 holes that were generated by a specifically targeted sonic drilling program across the Area 1 deposit. The bulk sample was treated to a program of work to remove oversize and de-slime the parent sample in preparation for metallurgical testwork. The testwork was undertaken by Mineral Technologies.</p> <p>In addition to a THM head-grade, and slimes and oversize content details, the testwork produced a concentrate whose mineral assemblage was determined by ALS using QEMSCAN as described above.</p>

Criteria	JORC Code Explanation	Commentary
		Details of summary drillhole composite is presented in the appendices of the MRE report.
Further work	<p><i>The nature and scale of planned further work (e.g. tests for lateral extensions or depth extensions or large-scale step-out drilling).</i></p> <p><i>Diagrams clearly highlighting the areas of possible extensions, including the main geological interpretations and future drilling areas, provided this information is not commercially sensitive.</i></p>	<p>Additional work is required to provide further detailed information on the mineral assemblage of the THM.</p> <p>Further drilling may be planned if an economic analysis of the resource provides justification for such work.</p>

Section 3: Estimation and Reporting of Mineral Resources

(Criteria listed in section 1, and where relevant in section 2, also apply to this section)

Criteria	JORC Code Explanation	Commentary
Database integrity	<p><i>Measures taken to ensure that data has not been corrupted by, for example, transcription or keying errors, between its initial collection and its use for Mineral Resource estimation purposes.</i></p> <p><i>Data validation procedures used.</i></p>	<p>Exploration data is collected in the field using a data collection software package that uses validation routines to ensure no incorrect codes can be used during logging. That field data is uploaded the Company's Acquire database using validation routines.</p> <p>Laboratory assay files are also uploaded to the VHML database via routines the check the validity of the data.</p> <p>All data used in the resource estimate was downloaded directly from the VHML database in the form of csv files and then converted to Datamine files.</p> <p>Checks of data by visually inspecting on screen to identify translation of samples.</p> <p>Visual and statistical comparison was undertaken to check the validity of results.</p>
Site visits	<p><i>Comment on any site visits undertaken by the Competent Person and the outcome of those visits.</i></p> <p><i>If no site visits have been undertaken indicate why this is the case.</i></p>	<p>An extended site visit during the 2018 resource drilling phase in EL5220 (now RL6806) was converted to RL6806) was undertaken by Competent Person (Geology Manager) to observe the drilling data collection and sampling activities. No deficiencies were identified during the visit.</p>
Geological interpretation	<p><i>Confidence in (or conversely, the uncertainty of) the geological interpretation of the mineral deposit.</i></p> <p><i>Nature of the data used and of any assumptions made.</i></p> <p><i>The effect, if any, of alternative interpretations on Mineral Resource estimation.</i></p> <p><i>The use of geology in guiding and controlling Mineral Resource estimation.</i></p> <p><i>The factors affecting continuity both of grade and geology.</i></p>	<p>The geological interpretation was undertaken by VHML's Geologists using all logging, downhole gamma responses, and sampling data and observations.</p> <p>Current data spacing and quality is sufficient to indicate grade continuity.</p> <p>Interpretation of modelling domains was restricted to the main mineralised envelopes utilising THM, oversize, slimes, and geology logging. The interpretation of the domains was also aided by the utilisation of downhole gamma signatures produced by the geophysical logging which assisted with distinguishing domain boundaries in the Area 1 area. The Area 1 West resource area is defined by data generated using a 38 µm lower screen only. The Area 1 East Resource area incorporates data generated using both 38 µm and 20 µm lower screen sizes. To remove the possibility of mixed data populations, the 38 µm data was excluded from the Area 1 East MRE.</p> <p>Sachet logging was also undertaken by the company in relation to specific areas within the project to provide greater understanding of mineralogical domain (e.g. where it was not possible to obtain gamma signatures below the water table due to hole collapse).</p>

Criteria	JORC Code Explanation	Commentary
		<p>The MRE was controlled by the topographic surface and a series of wireframed surfaces delineating the mineralised domain.</p> <p>The mineralisation is apparently open to the north, south, east, and west.</p>
Dimensions	<p><i>The extent and variability of the Mineral Resource expressed as length (along strike or otherwise), plan width, and depth below surface to the upper and lower limits of the Mineral Resource.</i></p>	<p>The current resource has been defined as being approximately 2,000 m (north-south) on average, and 4,000 m wide east-west). It is approximately 10–12 m thick and is buried by an average of 16 m of overburden.</p>
Estimation and modelling techniques	<p><i>The nature and appropriateness of the estimation technique(s) applied and key assumptions, including treatment of extreme grade values, domaining, interpolation parameters and maximum distance of extrapolation from data points. If a computer assisted estimation method was chosen include a description of computer software and parameters used.</i></p> <p><i>The availability of check estimates, previous estimates and/or mine production records and whether the Mineral Resource estimate takes appropriate account of such data.</i></p> <p><i>The assumptions made regarding recovery of by-products.</i></p> <p><i>Estimation of deleterious elements or other non-grade variables of economic significance (e.g. sulphur for acid mine drainage characterisation).</i></p> <p><i>In the case of block model interpolation, the block size in relation to the average sample spacing and the search employed.</i></p> <p><i>Any assumptions behind modelling of selective mining units.</i></p> <p><i>Any assumptions about correlation between variables.</i></p> <p><i>Description of how the geological interpretation was used to control the resource estimates.</i></p> <p><i>Discussion of basis for using or not using grade cutting or capping.</i></p> <p><i>The process of validation, the checking process used, the comparison of model data to drillhole data, and use of reconciliation data if available.</i></p>	<p>The MRE was conducted using Datamine Studio RM. Ordinary Kriging was used to interpolate assay grades from drillhole samples into most of the block model.</p> <p>A metallurgical bulk sample was created from drillhole samples (as described below). An envelope, that encapsulated the samples used to create the bulk sample and the aircore samples around them, was created as a “3D solid” (wireframe) in Datamine and used to constrain the application of the metallurgical testwork data in the MRE. THM grades of model cells within the envelope from where the samples used to create the 9.1-tonne bulk sample were taken were set to a fixed grade of 5.72% THM, which was determined during the metallurgical testwork that was conducted using the 9.1-tonne bulk sample. This was appropriate as the bulk sample is representative of that envelope. The metallurgical testwork used a screen size of 20 µm and showed considerable uplift in recovery of heavy mineral compared to the individual sample grades of the “as-drilled” samples.</p> <p>Nearest neighbour techniques were used to interpolate mineral assemblage, index values and non-numeric sample identification into the block model.</p> <p>As with the THM, slimes and oversize values, the mineral assemblage, which was derived by the bulk sample testwork, was used to overwrite, and inform the model cells within the bulk sample envelope.</p> <p>The mostly regular dimensions of the drill grid and the isotropy of the drilling and sampling grid allowed for the use of Ordinary Kriging.</p> <p>A Kriging Neighbourhood Analysis was undertaken to guide the selection of model parent block size, discretisation point arrays, required sample population information etc. The parent cell size used for the interpolation was approximately half the standard drillhole width and half the standard drillhole section line spacing.</p> <p>Variography was used to develop search directions and extents.</p> <p>Appropriate search ellipses were used to search for data for the interpolation and suitable limitations on the number of samples and the impact of those samples was maintained. Hard domain boundaries were used, and these were defined by the geological outlines that were interpreted.</p> <p>No assumptions were made during the resource estimation as to the recovery of by-products.</p> <p>Slimes and oversize contents are estimated at the same time as estimating the THM grade.</p> <p>Further detailed geochemistry is required to ascertain deleterious elements that may affect the marketability of the heavy mineral products.</p>

Criteria	JORC Code Explanation	Commentary
		<p>No assumptions were made regarding the modelling of selective mining units; however, it is assumed that a form of dry mining will be undertaken, and the cell size and the sub-cell splitting will allow for an appropriate dry mining preliminary reserve to be prepared. Any other mining methodology will be more than adequately catered for with the parent cell size that was selected for the modelling exercise.</p> <p>No assumptions were made about correlation between variables.</p> <p>Grade cutting or capping was not used during the interpolation because of the regular nature of sample spacing and the fact that samples were not clustered nor wide spaced to an extent where elevated samples could have a deleterious impact on the resource estimation.</p> <p>Sample distributions were reviewed, and no extreme outliers were identified either high or low that necessitated any grade cutting or capping.</p> <p>The sample length of 1 m does result in a degree of grade smoothing also negating the requirement for grade cutting or capping.</p> <p>Validation of grade interpolations were done visually in Datamine software by loading model and drillhole files and annotating and colouring and using filtering to check for the appropriateness of interpolations.</p> <p>Statistical distributions were prepared for model zones from drillhole and model files to compare the effectiveness of the interpolation for each mineralised domain.</p> <p>Along-strike distributions of section line averages (swath plots) for drillholes and models were also prepared for comparison purposes.</p>
Moisture	<i>Whether the tonnages are estimated on a dry basis or with natural moisture, and the method of determination of the moisture content.</i>	Tonnages were estimated on an assumed dry basis as the mineralisation is located above the current water table.
Cut-off parameters	<i>The basis of the adopted cut-off grade(s) or quality parameters applied.</i>	Cut-off grade for THM was used to prepare the reported resource estimates. A 1.0% cut-off grade was used at the suggestion of VHML's Geology Manager.
Mining factors or assumptions	<i>Assumptions made regarding possible mining methods, minimum mining dimensions and internal (or, if applicable, external) mining dilution. It is always necessary as part of the process of determining reasonable prospects for eventual economic extraction to consider potential mining methods, but the assumptions made regarding mining methods and parameters when estimating Mineral Resources may not always be rigorous. Where this is the case, this should be reported with an explanation of the basis of the mining assumptions made.</i>	No specific mining method is assumed other than potentially the use of dry mining methods.

Criteria	JORC Code Explanation	Commentary
Metallurgical factors or assumptions	<i>The basis for assumptions or predictions regarding metallurgical amenability. It is always necessary as part of the process of determining reasonable prospects for eventual economic extraction to consider potential metallurgical methods, but the assumptions regarding metallurgical treatment processes and parameters made when reporting Mineral Resources may not always be rigorous. Where this is the case, this should be reported with an explanation of the basis of the metallurgical assumptions made.</i>	<p>A metallurgical testwork program was undertaken on a 9.1-tonne bulk sample by Mineral Technologies.</p> <p>The processing of a 9.1-tonne bulk sample of Area 1 ore through a feed preparation circuit used a combination of scrubbing, screening, and de-sliming to prepare feed suitable for subsequent beneficiation. The data showed:</p> <ul style="list-style-type: none"> • The calculated FPC feed assayed 2.7% TiO₂, 1.3% ZrO₂ and 0.08% CeO₂ and agreed with the characterisation testwork grade. • The prepared sample after scrubbing, screening and de-sliming accounted for 80% by weight of the feed; with 5.7% by weight of the feed sample reporting to the oversize stream and 14.3% by weight of the feed sample reporting to the slimes. • Testwork recovery of -1.0+0.020 mm TiO₂ to the de-slimed and screened sample was 90.7% relative to the FPC feed. • Testwork recovery of -1.0+0.020 mm ZrO₂ to the de-slimed and screened sample was 96.9% relative to the FPC feed. • Testwork recovery of -1.0+0.020 mm CeO₂ to the de-slimed and screened sample was 93.6% relative to the FPC feed. • The very high recovery of +20 µm TiO₂, ZrO₂ and CeO₂ validated the suitability of the FPC to produce feed for beneficiation with minimal loss of valuable to slimes or oversize. <p>No recoveries were used or accounted for in the reporting of the MRE.</p>
Environmental factors or assumptions	<i>Assumptions made regarding possible waste and process residue disposal options. It is always necessary as part of the process of determining reasonable prospects for eventual economic extraction to consider the potential environmental impacts of the mining and processing operation. While at this stage the determination of potential environmental impacts, particularly for a greenfields project, may not always be well advanced, the status of early consideration of these potential environmental impacts should be reported. Where these aspects have not been considered this should be reported with an explanation of the environmental assumptions made.</i>	<p>No assumptions have been made regarding possible waste and process residue; however, disposal of by products such as SLIMES, sand and oversize are normally part of capture and disposal back into the mining void for eventual rehabilitation. This also applies to gangue mineral products recovered and waste products recovered from metallurgical processing of heavy mineral.</p>
Bulk density	<i>Whether assumed or determined. If assumed, the basis for the assumptions. If determined, the method used, whether wet or dry, the frequency of the measurements, the nature, size, and representativeness of the samples.</i> <i>The bulk density for bulk material must have been measured by methods that adequately account for void spaces (vugs, porosity, etc.), moisture and differences between rock and alteration zones within the deposit.</i>	<p>A bulk density algorithm was prepared using first principles techniques coupled with industry experience. It is believed that the bulk density formula is conservative and fit for purpose at this level of confidence for the MREs and based on our experience however bulk density testwork should be undertaken going forward.</p> <p>A bulk density was applied to the model using a standard linear formula originally described by Baxter (1977). This regression formula was then used to calculate the conversion of tonnes from each cell volume and from there the calculation of material, THM and SLIMES tonnes.</p> <p>The bulk density formula is described as: Bulk Density = (0.009 * THM) + 1.698.</p>

Criteria	JORC Code Explanation	Commentary
	<i>Discuss assumptions for bulk density estimates used in the evaluation process of the different materials.</i>	
Classification	<p><i>The basis for the classification of the Mineral Resources into varying confidence categories.</i></p> <p><i>Whether appropriate account has been taken of all relevant factors (i.e. relative confidence in tonnage/grade estimations, reliability of input data, confidence in continuity of geology and metal values, quality, quantity, and distribution of the data).</i></p> <p><i>Whether the result appropriately reflects the Competent Person's view of the deposit.</i></p>	<p>The resource classification for the Goschen Area 1 deposit was based on the following criteria: drillhole spacing, geological and grade continuity, variography of primary assay grades and the distribution of composited assemblage data.</p> <p>The classification of the Measured and Indicated Mineral Resources was supported by all the criteria as noted above.</p> <p>The Company used both Snowden's 2017 recommendations for classification of mineral resource and VHML's internal geostatistical evaluation as input to classification process.</p> <p>Competent Persons reviewed geological data from cross sections and associated plan view maps as part of the classification process. Combinations of geological data were viewed both on light table and as 3D models on screen.</p> <p>The Company considers that the use of metallurgical data complied with JORC 2012 clause 49 and ensures resource aligns with metallurgy outcomes.</p>
Audits or reviews	<i>The results of any audits or reviews of Mineral Resource estimates.</i>	<p>CSA Global has undertaken a preliminary review of the draft MRE Report and raised issues with the quality of aspects of the variography (remedied), the methods used to validate the resource estimate (improved statistics) and the inclusion of the metallurgical testwork as part of the MRE. The Company has addressed all the issues raised by CSA Global. A review of the final MRE and associated report by CSA Global is pending.</p>
Discussion of relative accuracy/ confidence	<p><i>Where appropriate a statement of the relative accuracy and confidence level in the Mineral Resource estimate using an approach or procedure deemed appropriate by the Competent Person. For example, the application of statistical or geostatistical procedures to quantify the relative accuracy of the resource within stated confidence limits, or, if such an approach is not deemed appropriate, a qualitative discussion of the factors that could affect the relative accuracy and confidence of the estimate.</i></p> <p><i>The statement should specify whether it relates to global or local estimates, and, if local, state the relevant tonnages, which should be relevant to technical and economic evaluation. Documentation should include assumptions made and the procedures used.</i></p> <p><i>These statements of relative accuracy and confidence of the estimate should be compared with production data, where available.</i></p>	<p>The regular nature of the drillhole spacing means that no local variations were produced or able to be analysed during the mineral resource estimation process.</p> <p>Validation of the model vs drillhole grades by sectional comparisons, statistical evaluation, swathe plot and population distribution analysis were favourable.</p> <p>The statement refers to global estimates for the entire known extent of the Goschen Area 1 deposit.</p> <p>No production data is available for comparison with the deposit.</p>

Appendix C: Area 3 Extended – JORC Table 1 (JORC Code, 2012 Edition)

Competent Person:	Graham Howard
Report Title:	Areas 3 Extended Mineral Resource Estimate Report
Report Reference:	RPP727
Date Reported:	21 August 2020

Section 1: Sampling Techniques and Data

(Criteria in this section apply to all succeeding sections)

Criteria	JORC Code Explanation	Commentary
Sampling techniques	<p><i>Nature and quality of sampling (e.g. cut channels, random chips, or specific specialised industry standard measurement tools appropriate to the minerals under investigation, such as down hole gamma sondes, or handheld XRF instruments, etc.). These examples should not be taken as limiting the broad meaning of sampling.</i></p> <p><i>Include reference to measures taken to ensure sample representivity and the appropriate calibration of any measurement tools or systems used.</i></p> <p><i>Aspects of the determination of mineralisation that are Material to the Public Report.</i></p> <p><i>In cases where 'industry standard' work has been done this would be relatively simple (e.g. 'reverse circulation drilling was used to obtain 1 m samples from which 3 kg was pulverised to produce a 30 g charge for fire assay'). In other cases, more explanation may be required, such as where there is coarse gold that has inherent sampling problems. Unusual commodities or mineralisation types (e.g. submarine nodules) may warrant disclosure of detailed information.</i></p>	<p>Aircore (AC) drilling was used to obtain samples at 1 m intervals for 2019 drilling. The following information covers the sampling process:</p> <ul style="list-style-type: none"> The full 1 m drill samples were split down to approximately ~1,000 g to ~2500 g by rotary splitter mounted on the drilling rig. Each 1 m composite subsample was homogenised by manually mixing the sample within the sample bag. A sample of sand of approximately 20 g is scooped from the sample bag for visual estimation of heavy mineral and slimes content and sample description. The same mass of sample is consistently used for each panned sample to ensure calibration is maintained for consistency in visual estimation. Sample logging software is used at the drill rig for recording sample intervals and descriptions. The sample bag is sealed and dispatched to a commercial laboratory for analysis. The laboratory sample was oven dried at 105°C for a minimum of 2 hours (and then re-dried for up to 12 hours if required), and split down to 100 g subsamples via a rotating splitter fed by a vibrating screen. A laboratory repeat was taken at ~1:25 samples. All drillhole subsamples were screened using vibrating screens with a top screen of either 1 mm or 2 mm mesh and a bottom screen of 38 µm. Oversize (+1 mm or 2 mm fraction) was removed and -38 µm fraction (SLIMES) discarded. The sand fraction (1 mm or 2 mm to +38 µm) was then submitted for heavy liquid separation (HLS) using TBE to determine total heavy mineral (THM) content. Duplicates were taken at the drill rig by hanging sample bags side-by-side on the rotary splitter at a rate of ~1:20. Duplicates were taken within mineralisation zones as the waste material was excluded from sampling. Commercially obtained standards were inserted by the laboratory at a rate of ~1:40.
Drilling techniques	<p><i>Drill type (e.g. core, reverse circulation, open-hole hammer, rotary air blast, auger, Bangka, sonic, etc.) and details (e.g. core diameter, triple or standard tube, depth of diamond tails, face-sampling bit, or other type, whether core is oriented and if so, by what method, etc.).</i></p>	<p>Wallis Drilling was the contractor used for the drilling and sampling program upon which the Goschen Area 3 Extended Mineral Resource estimate (MRE) was based. AC drilling, which is a standard technique for the heavy mineral sand industry, was used. AC drilling is a form of reverse circulation drilling where the sample is collected at the face and returned inside the inner tube.</p> <p>All drillholes were vertical and were drilled using NQ-sized drill string and bits. Drill rods were three metres long.</p>

Criteria	JORC Code Explanation	Commentary
Drill sample recovery	<p><i>Method of recording and assessing core and chip sample recoveries and results assessed.</i></p> <p><i>Measures taken to maximise sample recovery and ensure representative nature of the samples.</i></p> <p><i>Whether a relationship exists between sample recovery and grade and whether sample bias may have occurred due to preferential loss/gain of fine/coarse material.</i></p>	<p>Drill sample recovery is monitored by recording sample condition from “dry good” to “wet poor”.</p> <p>While initially collaring the hole, limited sample recovery can occur in the initial 0–1 m sample interval owing to sample and air loss into the surrounding loose soil. The initial 0–1 m sample interval is drilled very slowly in order to achieve optimum sample recovery.</p> <p>Each entire 1 m sample apart from the subsample taken for logging and analysis) is collected at the drill rig in large, numbered plastic bags for dispatch to the initial split preparation facility.</p> <p>At the end of each drill rod, the drill string is cleaned by blowing down with air to remove any clay and silt potentially built up in the sample tubes.</p> <p>The twin-tube AC drilling technique is known to provide high-quality samples from the face of the drillhole (in ideal conditions).</p>
Logging	<p><i>Whether core and chip samples have been geologically and geotechnically logged to a level of detail to support appropriate Mineral Resource estimation, mining studies and metallurgical studies.</i></p> <p><i>Whether logging is qualitative or quantitative in nature. Core (or costean, channel, etc) photography.</i></p> <p><i>The total length and percentage of the relevant intersections logged.</i></p>	<p>Each AC sample was qualitatively logged into a field-validated data capture software package, and later uploaded to the AcQuire database.</p> <p>The samples were logged for lithology, colour, grain size, sorting, hardness, sample condition, washability, estimated heavy mineral content, estimated slimes content and any relevant comments - such as slope, vegetation, or cultural activity.</p> <p>Every drillhole was logged in full.</p> <p>Logging is undertaken with reference to a Drilling Guideline with codes prescribed and guidance on description to ensure consistent and systematic data collection.</p>
Subsampling techniques and sample preparation	<p><i>If core, whether cut or sawn and whether quarter, half or all core taken.</i></p> <p><i>If non-core, whether riffled, tube sampled, rotary split, etc and whether sampled wet or dry.</i></p> <p><i>For all sample types, the nature, quality, and appropriateness of the sample preparation technique.</i></p> <p><i>Quality control procedures adopted for all subsampling stages to maximise representivity of samples.</i></p> <p><i>Measures taken to ensure that the sampling is representative of the in-situ material collected, including for instance results for field duplicate/second-half sampling.</i></p> <p><i>Whether sample sizes are appropriate to the grain size of the material being sampled.</i></p>	<p>The 1 m sample interval is rotary split at the drill rig. A total of ~1.2 kg to ~2.5 kg of each sample was placed into calico sample bags and exported to Diamantina Laboratory for THM analysis.</p> <p>The water table depth, if intersected, was noted in all geological logs and when water injection was required to aid sample recovery the sample was logged as “wet poor”.</p> <p>Almost all the samples are silty sand, sand, sandy clay, clayey sand, or clay and this sample preparation method is considered appropriate.</p> <p>The sample sizes were deemed suitable to reliably capture THM, slime, and oversize characteristics, based on industry experience of the geologists involved and consultation with laboratory staff.</p> <p>Field duplicates of the samples were completed at a frequency of 1:20 primary samples.</p>
Quality of assay data and laboratory tests	<p><i>The nature, quality and appropriateness of the assaying and laboratory procedures used and whether the technique is considered partial or total.</i></p> <p><i>For geophysical tools, spectrometers, handheld XRF instruments, etc., the parameters used in determining the analysis including instrument make and model, reading times, calibrations factors applied and their derivation, etc.</i></p>	<p>The wet panning at the drill site provides an estimate of the THM % which is sufficient for the purpose of determining approximate concentrations of THM in the first instance.</p> <p>AC sample:</p> <ul style="list-style-type: none"> • The individual 1 m AC subsamples were assayed by Diamantina Laboratories in Perth, Western Australia, which is considered the Primary laboratory. • The samples were initially oven dried at 105°C for 2 hours (and then up to 12 hours for very wet samples) then reduced on a rotary splitter by 15%. Samples were then riffle split to 100 g sub-splits (weighed and captured) and then left to soak overnight.

Criteria	JORC Code Explanation	Commentary
	<i>Nature of quality control procedures adopted (e.g. standards, blanks, duplicates, external laboratory checks) and whether acceptable levels of accuracy (i.e. lack of bias) and precision have been established.</i>	<ul style="list-style-type: none"> All samples were then wet washed and sieved on vibrating screens using a top screen of +1 or +2 mm to remove the very coarse sand, pebbles, or grits. The bottom screen used 38 µm mesh for removal and determination of the -38 µm fraction (SLIMES). The remaining sand fraction (-2 mm +38 µm) was then submitted to HLS. The laboratory used TBE as the heavy liquid medium – with density range between 2.92 g/ml and 2.96 g/ml. The density of the heavy liquid was checked every day. This is an industry standard technique. Field duplicates of the samples were collected and submitted at a frequency of 1:20 primary samples. Diamantina Laboratories completed its own internal quality assurance and quality control (QAQC) checks that included laboratory standards every 40th sample and a Laboratory repeat every 25th sample prior to the results being released. Analysis of QAQC samples show the laboratory data to be of acceptable accuracy and precision. The adopted QAQC protocols are acceptable for this stage of testwork.
Verification of sampling and assaying	<p><i>The verification of significant intersections by either independent or alternative company personnel.</i></p> <p><i>The use of twinned holes.</i></p> <p><i>Documentation of primary data, data entry procedures, data verification, data storage (physical and electronic) protocols.</i></p> <p><i>Discuss any adjustment to assay data.</i></p>	<p>All results were checked by the Company's Geology Manager.</p> <p>The Company's Geology Manager and an independent Resource Geologist made periodic visits to Diamantina Laboratories to observe sample processing and procedure. A process of laboratory data validation using mass balance is undertaken to identify entry errors or questionable data. Field and laboratory duplicate data pairs (THM/OS/SLIME) of each batch are plotted to identify potential quality control issues.</p> <p>Standard Reference Material sample results are checked from each sample batch to ensure they are within tolerance (<3SD) and that there is no bias.</p> <p>The field and laboratory data were exported from the VHM's AcQuire database and imported into Datamine by a geologist contracted to VHM Limited (VHML), which is appropriate for this stage in the program. Data validation criteria are included to check for overlapping sample intervals, end of hole match between "Lithology", "Sample", "Survey" files and other common errors.</p>
Location of data points	<p><i>Accuracy and quality of surveys used to locate drillholes (collar and downhole surveys), trenches, mine workings and other locations used in Mineral Resource estimation.</i></p> <p><i>Specification of the grid system used.</i></p> <p><i>Quality and adequacy of topographic control.</i></p>	<p>Drillhole collar locations were surveyed by an independent surveyor using industry standard equipment. Three permanent survey marks in the area provided survey control, allowing for repeatable and accurate survey readings across the project area.</p> <p>The datum used is GDA 94 and coordinates are projected as MGA Zone 54.</p> <p>A digital topographic surface was generated by VHML from data collected during a light detection and ranging (LiDAR) survey commissioned by VHML. The accuracy of the locations is sufficient for this stage of exploration.</p>
Data spacing and distribution	<i>Data spacing for reporting of Exploration Results.</i>	160 drillholes were used to inform the resource estimate. 91 were drilled in 2017, two were drilled in 2018 and the remaining 67 were completed in January/February 2019.

Criteria	JORC Code Explanation	Commentary
	<p><i>Whether the data spacing, and distribution is sufficient to establish the degree of geological and grade continuity appropriate for the Mineral Resource and Ore Reserve estimation procedure(s) and classifications applied.</i></p> <p><i>Whether sample compositing has been applied.</i></p>	<p>Holes drilled in 2017 were drilled on an offset pattern with spacing between collars of 300–400 m. The program conducted during 2019 comprised holes drilled at 100/50m spacing along east-west traverses which were spaced at 400 m.</p> <p>The collar spacing is sufficient to provide a high degree of confidence in geological model and grade continuity within the holes at this stage.</p> <p>Each AC drill sample is a single 1 m sample of sediment intersected down the hole.</p> <p>No downhole compositing has been applied to models for values of THM, slime and oversize.</p> <p>Compositing of samples was undertaken on THM concentrates for mineral assemblage determination. Composite samples were determined by geological domains</p>
Orientation of data in relation to geological structure	<p><i>Whether the orientation of sampling achieves unbiased sampling of possible structures and the extent to which this is known, considering the deposit type.</i></p> <p><i>If the relationship between the drilling orientation and the orientation of key mineralised structures is considered to have introduced a sampling bias, this should be assessed and reported if material.</i></p>	<p>The mineralisation at the Goschen Area 3 prospect is a largely flat-lying (with some soft sediment deformation across a basement fault) sedimentary package which does not display a strong orientation of mineralisation at the current sample spacing.</p>
Sample security	<p><i>The measures taken to ensure sample security.</i></p>	<p>Aircore samples were stored on site (at a dedicated warehouse in Kerang).</p> <p>The samples were then dispatched to Perth using Swan Hill Freight agents and delivered directly to the Diamantina Laboratory.</p> <p>The laboratory inspected the packages and did not report tampering of the samples.</p>
Audits or reviews	<p><i>The results of any audits or reviews of sampling techniques and data.</i></p>	<p>Internal reviews were undertaken during the geological interpretation and throughout the modelling process.</p>

Section 2: Reporting of Exploration Results

(Criteria listed in the preceding section also apply to this section)

Criteria	JORC Code Explanation	Commentary
Mineral tenement and land tenure status	<p><i>Type, reference name/number, location and ownership including agreements or material issues with third parties such as joint ventures, partnerships, overriding royalties, native title interests, historical sites, wilderness or national park and environmental settings.</i></p> <p><i>The security of the tenure held at the time of reporting along with any known impediments to obtaining a licence to operate in the area.</i></p>	<p>The exploration work was completed on tenements that are 100% owned by VHML in Victoria, Australia.</p> <p>The drill samples for this MRE were drilled and collected from Exploration Licence 5520.</p> <p>The exploration licence original date of grant was 10 October 2014 with an expiry date of 9 October 2019. A Retention Licence to replace the exploration licence was granted by Earth Resources Regulation, which is the responsible statutory body and part of Victorian Department of Jobs, Precincts and Regions, in January 2020.</p>
Exploration done by other parties	<p><i>Acknowledgment and appraisal of exploration by other parties.</i></p>	<p>Historic exploration work was completed by previous exploration companies including Austiex (1977–1978), CRA Exploration (1981–1987), Renison Goldfields Consolidated (1980–1991), WJ Holdings (1998), RZM Group (1999), Basin Minerals (2001), Providence Gold and Minerals (2004–2005), and Iluka (2009).</p>

Criteria	JORC Code Explanation	Commentary
		<p>The Company has obtained the hardcopy reports and maps in relation to this information as part of its historical review in preparation for their current work program.</p> <p>The historical data comprises surface sampling, limited AC drilling and mapping.</p> <p>The current resource estimate is based solely on work conducted by VHML.</p>
Geology	<i>Deposit type, geological setting, and style of mineralisation.</i>	<p>The heavy mineral sands at the Goschen Project is a fine-grained deposit hosted within the offshore depositional paleo-environment of the Loxton Parilla Sands. The Loxton-Parilla Sand is common within the Murray Basin and hosts all known mineral sand deposits in the Basin. Alluvial sediments of the Shepparton Formation have been deposited over the Loxton-Parilla Sand and the Bookpurnong Formation consisting of shallow marine clays and marls is positioned below within the lithological sequence.</p>
Drillhole information	<p><i>A summary of all information material to the understanding of the exploration results including a tabulation of the following information for all Material drillholes:</i></p> <ul style="list-style-type: none"> • <i>easting and northing of the drillhole collar</i> • <i>elevation or RL (Reduced Level – elevation above sea level in metres) of the drillhole collar</i> • <i>dip and azimuth of the hole</i> • <i>downhole length and interception depth</i> • <i>hole length.</i> <p><i>If the exclusion of this information is justified on the basis that the information is not Material and this exclusion does not detract from the understanding of the report, the Competent Person should clearly explain why this is the case.</i></p>	<p>All relevant drillhole data is reported in the Resource Report describing the resource estimate for the Goschen Area 3 Extended project.</p>
Data aggregation methods	<p><i>In reporting Exploration Results, weighting averaging techniques, maximum and/or minimum grade truncations (e.g. cutting of high grades) and cut-off grades are usually Material and should be stated.</i></p> <p><i>Where aggregate intercepts incorporate short lengths of high grade results and longer lengths of low grade results, the procedure used for such aggregation should be stated and some typical examples of such aggregations should be shown in detail.</i></p> <p><i>The assumptions used for any reporting of metal equivalent values should be clearly stated.</i></p>	<p>No data aggregation methods were utilised, no top cuts were employed, and all cut-off grades have been reported.</p>
Relationship between mineralisation widths and intercept lengths	<p><i>These relationships are particularly important in the reporting of Exploration Results.</i></p>	<p>The nature of the mineralisation is horizontal, thus vertical AC holes represent the true thicknesses of the mineralisation.</p> <p>Downhole widths are reported.</p>

Criteria	JORC Code Explanation	Commentary
	<p><i>If the geometry of the mineralisation with respect to the drillhole angle is known, its nature should be reported.</i></p> <p><i>If it is not known and only the downhole lengths are reported, there should be a clear statement to this effect (e.g. 'downhole length, true width not known').</i></p>	
Diagrams	<p><i>Appropriate maps and sections (with scales) and tabulations of intercepts should be included for any significant discovery being reported. These should include, but not be limited to a plan view of drillhole collar locations and appropriate sectional views.</i></p>	Plan view and typical cross sections provided in resource report.
Balanced reporting	<p><i>Where comprehensive reporting of all Exploration Results is not practicable, representative reporting of both low and high grades and/or widths should be practiced to avoid misleading reporting of Exploration Results.</i></p>	Exploration Results have been reported in resource report at THM >1% to indicate a range of potential tonnes and grade.
Other substantive exploration data	<p><i>Other exploration data, if meaningful and material, should be reported including (but not limited to): geological observations; geophysical survey results; geochemical survey results; bulk samples – size and method of treatment; metallurgical test results; bulk density, groundwater, geotechnical and rock characteristics; potential deleterious or contaminating substances.</i></p>	<p>Detailed mineral assemblage work was undertaken on composite samples for the Project by ALS Metallurgy Services, Perth and by Bureau Veritas in Adelaide. ALS applied an integrated mineralogical approach using both x-ray fluorescence (XRF) analysis and Quantitative Evaluation of Minerals by Scanning Electron Microscopy (QEMSCAN). Bureau Veritas also use QEMSCAN for mineralogical determinations but use a combination of XRF and laser ablation techniques for chemical assay. These techniques were used to gain a quantitative understanding of the elemental composition and mineralogical assemblage.</p> <p>The XRF and laser ablation techniques provide measurements of relative elemental abundances (down to limits of a few parts per million) which allows for a quantifiable basis for determination of mineralogy, provenance, depositional environment, and diagenetic history. The XRF analysis was utilised to apply assay data to the geological model for grade interpretation.</p> <p>The QEMSCAN method of analysis required the samples to be screened into +150 µm and -150 µm screen fraction prior to sample preparation and QEMSCAN analysis.</p> <p>Sample preparation required each subsample was mixed with size-graded, high purity graphite to ensure particle separation and discourage density segregation. These sample-graphite mixtures were then set into moulds using a two-part epoxy resin, producing a representative subsample of randomly orientated particles. Once cured, the resin blocks were then cut to expose a fresh surface which is then gradually ground and polished. Once QAQC checks are completed the sections are then carbon coated for electron beam conductivity and presented to QEMSCAN for analysis.</p> <p>The samples were analysed using QEMSCAN technology in Field Scan mode and Particle Mineralogical Analysis mode.</p>

Criteria	JORC Code Explanation	Commentary
		<p>For the samples acquired in 2019 detailed sachet scanning of heavy mineral sinks from the drill assay process was carried out to determine regions of gross mineralogy as well as an overall consideration of valuable heavy mineral (VHM) content. Other considerations undertaken during this sachet logging were the presence of iron oxide coatings on THM, and any gross composition of trash heavy minerals. Sachet logging then had partial input into the geological/mineralogical/THM grade interpretation which then assisted with domain control for modelling, as well as providing guidance for the allocation of mineral assemblage composites where it was not possible to get gamma data due to hole collapse.</p> <p>Pre-2019 composite samples were generated solely on heavy mineral grades, which were used to generate geological domain boundaries. These composite samples frequently include zones of high gangue content and iron cemented sand. As a result, many of the early composites are not representative of the true mineralised zones and mineralogical results are downgraded by trash and iron oxide. Many of these sample were, therefore, omitted from the dataset used to inform the resource estimate.</p> <p>Once the sample compositing was completed, the sample identification and mineral assemblage composite number was submitted to the labs listed above for mineralogical determination.</p> <p>In 2018, a 1.8-tonne bulk sample was created by compositing 343, 5–6 kg, excess drill cuttings from the mineralised zones of 86 holes which were drilled in 2017. The bulk sample was treated to a program of work to remove oversize and de-slime the parent sample in preparation for metallurgical testwork. The testwork was undertaken by Mineral Technologies.</p> <p>In addition to a THM head-grade, and slimes and oversize content details, the testwork produced a concentrate whose mineral assemblage was determined by ALS using QEMSCAN as described above.</p> <p>Details of summary drillhole composite is presented in the appendices of the MRE report.</p>
Further work	<p><i>The nature and scale of planned further work (e.g. tests for lateral extensions or depth extensions or large-scale step-out drilling).</i></p> <p><i>Diagrams clearly highlighting the areas of possible extensions, including the main geological interpretations and future drilling areas, provided this information is not commercially sensitive.</i></p>	<p>Additional work is required to provide further detailed information on the mineral assemblage of the THM.</p> <p>Further drilling may be planned if an economic analysis of the resource provides justification for such work.</p>

Section 3: Estimation and Reporting of Mineral Resources

(Criteria listed in section 1, and where relevant in section 2, also apply to this section)

Criteria	JORC Code Explanation	Commentary
Database integrity	<p><i>Measures taken to ensure that data has not been corrupted by, for example, transcription or keying errors, between its initial collection and its use for Mineral Resource estimation purposes.</i></p> <p><i>Data validation procedures used.</i></p>	<p>Exploration data is collected in the field using a data collection software package that uses validation routines to ensure no incorrect codes can be used during logging. That field data is uploaded the Company's AcQuire database using validation routines.</p> <p>Laboratory assay files are also uploaded to the VHML database via routines the check the validity of the data.</p>

Criteria	JORC Code Explanation	Commentary
		<p>All data used in the resource estimate was downloaded directly from the VHML database in the form of csv files and then converted to Datamine files.</p> <p>Checks of data by visually inspecting on screen to identify translation of samples.</p> <p>Visual and statistical comparison was undertaken to check the validity of results.</p>
Site visits	<p><i>Comment on any site visits undertaken by the Competent Person and the outcome of those visits.</i></p> <p><i>If no site visits have been undertaken indicate why this is the case.</i></p>	<p>An extended site visit during the 2019 resource drilling phase in EL5220 (now RL6806) was undertaken by Competent Person (Geology Manager) to observe the drilling data collection and sampling activities. No deficiencies were identified during the visit.</p>
Geological interpretation	<p><i>Confidence in (or conversely, the uncertainty of) the geological interpretation of the mineral deposit.</i></p> <p><i>Nature of the data used and of any assumptions made.</i></p> <p><i>The effect, if any, of alternative interpretations on Mineral Resource estimation.</i></p> <p><i>The use of geology in guiding and controlling Mineral Resource estimation.</i></p> <p><i>The factors affecting continuity both of grade and geology.</i></p>	<p>The geological interpretation was undertaken by VHML's Geologists using all logging, downhole gamma responses, and sampling data and observations.</p> <p>Current data spacing and quality is sufficient to indicate grade continuity.</p> <p>Interpretation of modelling domains was restricted to the main mineralised envelopes utilising THM, oversize, slimes, and geology logging. The interpretation of the domains was also aided by the utilisation of downhole gamma signatures produced by the geophysical logging which assisted with distinguishing domain boundaries in the Area 3 Extended area.</p> <p>Sachet logging was also undertaken by the company in relation to specific areas within the project to provide greater understanding of mineralogical domain (e.g. where it was not possible to obtain gamma signatures below the water table due to hole collapse).</p> <p>The MRE was controlled by the topographic surface and a wireframed solid describing the mineralised domain.</p> <p>The mineralisation is apparently open to the north, south, east, and west.</p>
Dimensions	<p><i>The extent and variability of the Mineral Resource expressed as length (along strike or otherwise), plan width, and depth below surface to the upper and lower limits of the Mineral Resource.</i></p>	<p>The current resource has been defined as being approximately 5,000 m (north-south) and 7,000 m wide (east-west). It is approximately 20 m thick and is buried by an average of 22 m of overburden.</p>
Estimation and modelling techniques	<p><i>The nature and appropriateness of the estimation technique(s) applied and key assumptions, including treatment of extreme grade values, domaining, interpolation parameters and maximum distance of extrapolation from data points. If a computer assisted estimation method was chosen include a description of computer software and parameters used.</i></p> <p><i>The availability of check estimates, previous estimates and/or mine production records and whether the Mineral Resource estimate takes appropriate account of such data.</i></p> <p><i>The assumptions made regarding recovery of by-products.</i></p> <p><i>Estimation of deleterious elements or other non-grade variables of economic significance (e.g. sulphur for acid mine drainage characterisation).</i></p>	<p>The MRE was conducted using Datamine Studio RM. Inverse distance weighting techniques were used to interpolate assay grades from drillhole samples into most of the block model. THM grades within Zone 1 of the Indicated Resource were set to a fixed grade of 5.42% THM, which was determined during the metallurgical testwork that was conducted using the 1.8-tonne bulk sample. This was appropriate as the bulk sample was largely composed of samples from within Zone 1 of the Indicated Resource. The metallurgical testwork used a screen size of 20 micron and showed considerable uplift in recovery of heavy mineral compared to the individual sample grades of the "as-drilled" samples, which used a screen size of 38 micron.</p>

Criteria	JORC Code Explanation	Commentary
	<p><i>In the case of block model interpolation, the block size in relation to the average sample spacing and the search employed.</i></p> <p><i>Any assumptions behind modelling of selective mining units.</i></p> <p><i>Any assumptions about correlation between variables.</i></p> <p><i>Description of how the geological interpretation was used to control the resource estimates.</i></p> <p><i>Discussion of basis for using or not using grade cutting or capping.</i></p> <p><i>The process of validation, the checking process used, the comparison of model data to drillhole data, and use of reconciliation data if available.</i></p>	<p>Nearest neighbour techniques were used to interpolate mineral assemblage, index values and nonnumeric sample identification into the block model. Due to the poor quality of the mineralogical data (QEMSCAN) related to incorrect composite selection, the mineral assemblage, which was derived by the bulk sample testwork, was used to inform the two main mineralised domains. These data were supported by the more carefully chosen mineral composites created from the 2019 drilling and so, along with the very large number of samples used from the mineralised domains to create the bulk sample, this step is considered as being appropriate.</p> <p>The mostly regular dimensions of the drill grid and the anisotropy of the drilling and sampling grid allowed for the use of inverse distance methodologies as no de-clustering of samples was required. Appropriate and industry standard search ellipses were used to search for data for the interpolation and suitable limitations on the number of samples and the impact of those samples was maintained. An inverse distance weighting power of 2 was used so as not to over smooth the grade interpolations. Hard domain boundaries were used, and these were defined by the geological outlines that were interpreted.</p> <p>No assumptions were made during the resource estimation as to the recovery of by-products.</p> <p>Slimes and oversize contents are estimated at the same time as estimating the THM grade.</p> <p>Further detailed geochemistry is required to ascertain deleterious elements that may affect the marketability of the heavy mineral products.</p> <p>The average parent cell size used for the interpolation was approximately half the standard drillhole width and half the standard drillhole section line spacing.</p> <p>No assumptions were made regarding the modelling of selective mining units; however, it is assumed that a form of dry mining will be undertaken, and the cell size and the sub cell splitting will allow for an appropriate dry mining preliminary reserve to be prepared. Any other mining methodology will be more than adequately catered for with the parent cell size that was selected for the modelling exercise.</p> <p>No assumptions were made about correlation between variables.</p> <p>Grade cutting or capping was not used during the interpolation because of the regular nature of sample spacing and the fact that samples were not clustered nor wide spaced to an extent where elevated samples could have a deleterious impact on the resource estimation.</p> <p>Sample distributions were reviewed, and no extreme outliers were identified either high or low that necessitated any grade cutting or capping.</p> <p>The sample length of 1 m does result in a degree of grade smoothing also negating the requirement for grade cutting or capping.</p> <p>Validation of grade interpolations were done visually in Datamine software by loading model and drillhole files and annotating and colouring and using filtering to check for the appropriateness of interpolations.</p>

Criteria	JORC Code Explanation	Commentary
		Statistical distributions were prepared for model zones from drillhole and model files to compare the effectiveness of the interpolation. Along strike distributions of section line averages (swath plots) for drillholes and models were also prepared for comparison purposes.
Moisture	<i>Whether the tonnages are estimated on a dry basis or with natural moisture, and the method of determination of the moisture content.</i>	Tonnages were estimated on an assumed dry basis as the mineralisation is located above the current water table.
Cut-off parameters	<i>The basis of the adopted cut-off grade(s) or quality parameters applied.</i>	Cut-off grade for THM was used to prepare the reported resource estimates. A 1.0% cut-off grade was used at the suggestion of VHML's Geology Manager.
Mining factors or assumptions	<i>Assumptions made regarding possible mining methods, minimum mining dimensions and internal (or, if applicable, external) mining dilution. It is always necessary as part of the process of determining reasonable prospects for eventual economic extraction to consider potential mining methods, but the assumptions made regarding mining methods and parameters when estimating Mineral Resources may not always be rigorous. Where this is the case, this should be reported with an explanation of the basis of the mining assumptions made.</i>	No specific mining method is assumed other than potentially the use of dry mining methods.
Metallurgical factors or assumptions	<i>The basis for assumptions or predictions regarding metallurgical amenability. It is always necessary as part of the process of determining reasonable prospects for eventual economic extraction to consider potential metallurgical methods, but the assumptions regarding metallurgical treatment processes and parameters made when reporting Mineral Resources may not always be rigorous. Where this is the case, this should be reported with an explanation of the basis of the metallurgical assumptions made.</i>	<p>A metallurgical testwork program was undertaken on a 1.8-tonne bulk sample by Mineral Technologies.</p> <p>The processing of a 1.8-tonne bulk sample of Area 3 ore through a feed preparation circuit (FPC) used a combination of scrubbing, screening, and de-sliming to prepare feed suitable for subsequent beneficiation. The data showed:</p> <ul style="list-style-type: none"> • The calculated FPC feed assayed 1.4% TiO₂, 0.6% ZrO₂ and 0.05% CeO₂ and agreed with the characterisation testwork grade. • The prepared sample after scrubbing, screening and de-sliming accounted for 79% by weight of the feed; with 7.5% by weight of the feed sample reporting to the oversize stream and 13.6% by weight of the feed sample reporting to the slimes. • The prepared sample assayed 1.7% TiO₂, 0.9% ZrO₂ and 0.06% CeO₂. • Testwork recovery of -1.0+0.020 mm TiO₂ to the de-slimed and screened sample was 98.2% relative to the FPC feed. • Testwork recovery of -1.0+0.020 mm ZrO₂ to the de-slimed and screened sample was 99.5% relative to the FPC feed. • Testwork recovery of -1.0+0.020 mm CeO₂ to the de-slimed and screened sample was 99.3% relative to the FPC feed. • The very high recovery of +20 µm TiO₂, ZrO₂ and CeO₂ validated the suitability of the FPC to produce feed for beneficiation with minimal loss of valuable to slimes or oversize. <p>No recoveries were used or accounted for in the reporting of the MRE.</p>

Criteria	JORC Code Explanation	Commentary
Environmental factors or assumptions	<i>Assumptions made regarding possible waste and process residue disposal options. It is always necessary as part of the process of determining reasonable prospects for eventual economic extraction to consider the potential environmental impacts of the mining and processing operation. While at this stage the determination of potential environmental impacts, particularly for a greenfields project, may not always be well advanced, the status of early consideration of these potential environmental impacts should be reported. Where these aspects have not been considered this should be reported with an explanation of the environmental assumptions made.</i>	No assumptions have been made regarding possible waste and process residue, however, disposal of by products such as SLIMES, sand and oversize are normally part of capture and disposal back into the mining void for eventual rehabilitation. This also applies to gangue mineral products recovered and waste products recovered from metallurgical processing of heavy mineral.
Bulk density	<i>Whether assumed or determined. If assumed, the basis for the assumptions. If determined, the method used, whether wet or dry, the frequency of the measurements, the nature, size, and representativeness of the samples. The bulk density for bulk material must have been measured by methods that adequately account for void spaces (vugs, porosity, etc), moisture and differences between rock and alteration zones within the deposit. Discuss assumptions for bulk density estimates used in the evaluation process of the different materials.</i>	A bulk density algorithm was prepared using first principles techniques coupled with industry experience. It is believed that the bulk density formula is conservative and fit for purpose at this level of confidence for the MREs and based on our experience, however, bulk density testwork should be undertaken going forward. A bulk density was applied to the model using a standard linear formula originally described by Baxter (1977). This regression formula was then used to calculate the conversion of tonnes from each cell volume and from there the calculation of material, THM and SLIMES tonnes. The bulk density formula is described as: Bulk Density = (0.009 * THM) + 1.698.
Classification	<i>The basis for the classification of the Mineral Resources into varying confidence categories. Whether appropriate account has been taken of all relevant factors (i.e. relative confidence in tonnage/grade estimations, reliability of input data, confidence in continuity of geology and metal values, quality, quantity, and distribution of the data). Whether the result appropriately reflects the Competent Person's view of the deposit.</i>	The resource classification for the Goschen Area 3 Extended deposit was based on the following criteria: drillhole spacing, geological and grade continuity, variography of primary assay grades and the distribution of composited assemblage data. The classification of the Indicated Mineral Resources was supported by all the supporting criteria as noted above. Inferred Mineral Resource classification was conferred on the parts of the resource where drilling spacing was wider yet still supported by variography and geological continuity. As a Competent Person, Graham Howard considers that the result appropriately reflects a reasonable view of the deposit.
Audits or reviews	<i>The results of any audits or reviews of Mineral Resource estimates.</i>	No audits or reviews of the MRE have been undertaken at this point in time.
Discussion of relative accuracy/ confidence	<i>Where appropriate a statement of the relative accuracy and confidence level in the Mineral Resource estimate using an approach or procedure deemed appropriate by the Competent Person. For example, the application of statistical or geostatistical procedures to quantify the relative accuracy of the resource within stated confidence limits, or, if such an approach is not deemed appropriate, a qualitative discussion of the factors that could affect the relative accuracy and confidence of the estimate.</i>	The regular nature of the drillhole spacing means that no local variations were produced or able to be analysed during the mineral resource estimation process. Validation of the model vs drillhole grades by sectional comparisons, swathe plot and population distribution analysis was favourable. The statement refers to global estimates for the entire known extent of the Goschen Area 3 Extended deposit. No production data is available for comparison with the deposit.

Criteria	JORC Code Explanation	Commentary
	<p><i>The statement should specify whether it relates to global or local estimates, and, if local, state the relevant tonnages, which should be relevant to technical and economic evaluation.</i></p> <p><i>Documentation should include assumptions made and the procedures used.</i></p> <p><i>These statements of relative accuracy and confidence of the estimate should be compared with production data, where available.</i></p>	

Appendix D: Area 1 and 3 – JORC Table (Section 4)

March 2023

Criteria	JORC Code Explanation	Commentary																																																																																																																																																																																																																																																																																																									
Mineral Resource estimate for conversion to Ore Reserves	<ul style="list-style-type: none"> Description of the Mineral Resource estimate used as a basis for the conversion to an Ore Reserve. Clear statement as to whether the Mineral Resources are reported additional to, or inclusive of, the Ore Reserves. 	<ul style="list-style-type: none"> The following comprises the Mineral Resources as at 30 June 2021: <table border="1"> <thead> <tr> <th>Area</th> <th>Resource Category</th> <th>Material (Mt)</th> <th>In situ THM (kt)</th> <th>Density (g/cm³)</th> <th>THM (%)</th> <th>Slimes (%)</th> <th>OS (%)</th> <th>Zircon (%)</th> <th>Rutile (%)</th> <th>LX (%)</th> <th>Ilmenite (%)</th> <th>Monsazite (%)</th> <th>Xenotime (%)</th> </tr> </thead> <tbody> <tr> <td rowspan="3">Area 1</td> <td>Measured</td> <td>30.7</td> <td>1.8</td> <td>1.76</td> <td>5.72</td> <td>15</td> <td>5</td> <td>29.9</td> <td>10.8</td> <td>9.0</td> <td>24.7</td> <td>4.3</td> <td>0.8</td> </tr> <tr> <td>Indicated</td> <td>62.2</td> <td>1.4</td> <td>1.72</td> <td>2.31</td> <td>18</td> <td>2</td> <td>26.6</td> <td>11.5</td> <td>9.2</td> <td>25.0</td> <td>4.6</td> <td>0.9</td> </tr> <tr> <td>Total</td> <td>92.9</td> <td>3.2</td> <td>1.73</td> <td>3.44</td> <td>17</td> <td>3</td> <td>27.7</td> <td>11.2</td> <td>9.1</td> <td>24.9</td> <td>4.5</td> <td>0.8</td> </tr> <tr> <td rowspan="2">Area 2 West</td> <td>Indicated</td> <td>26.0</td> <td>0.7</td> <td>1.72</td> <td>2.80</td> <td>20</td> <td>8</td> <td>22.0</td> <td>16.0</td> <td>12.0</td> <td>25.0</td> <td>3.0</td> <td>1.0</td> </tr> <tr> <td>Total</td> <td>26.0</td> <td>0.7</td> <td>1.72</td> <td>2.80</td> <td>20</td> <td>8</td> <td>22.0</td> <td>16.0</td> <td>12.0</td> <td>25.0</td> <td>3.0</td> <td>1.0</td> </tr> <tr> <td rowspan="3">Area 3</td> <td>Indicated</td> <td>204.1</td> <td>6.9</td> <td>1.73</td> <td>3.38</td> <td>19</td> <td>3</td> <td>19.2</td> <td>9.0</td> <td>8.0</td> <td>25.0</td> <td>3.2</td> <td>0.6</td> </tr> <tr> <td>Inferred</td> <td>287.7</td> <td>6.7</td> <td>1.72</td> <td>2.32</td> <td>18</td> <td>3</td> <td>17.2</td> <td>8.7</td> <td>7.5</td> <td>22.7</td> <td>2.9</td> <td>0.5</td> </tr> <tr> <td>Total</td> <td>491.8</td> <td>13.6</td> <td>1.73</td> <td>2.76</td> <td>18</td> <td>3</td> <td>18.2</td> <td>8.7</td> <td>7.7</td> <td>23.9</td> <td>3.0</td> <td>0.6</td> </tr> <tr> <td rowspan="2">Area 4</td> <td>Indicated</td> <td>18.0</td> <td>0.8</td> <td>1.74</td> <td>4.60</td> <td>20</td> <td>5</td> <td>19.0</td> <td>11.0</td> <td>10.0</td> <td>24.0</td> <td>3.0</td> <td>1.0</td> </tr> <tr> <td>Total</td> <td>18.0</td> <td>0.8</td> <td>1.74</td> <td>4.60</td> <td>20</td> <td>5</td> <td>19.0</td> <td>11.0</td> <td>10.0</td> <td>24.0</td> <td>3.0</td> <td>1.0</td> </tr> <tr> <td rowspan="3">Totals</td> <td>Measured</td> <td>30.7</td> <td>1.8</td> <td>1.76</td> <td>5.72</td> <td>15</td> <td>5</td> <td>29.9</td> <td>10.8</td> <td>9.0</td> <td>24.7</td> <td>4.3</td> <td>0.8</td> </tr> <tr> <td>Indicated</td> <td>310.3</td> <td>9.8</td> <td>1.73</td> <td>3.19</td> <td>19</td> <td>3</td> <td>20.5</td> <td>10.0</td> <td>8.6</td> <td>24.9</td> <td>3.4</td> <td>0.7</td> </tr> <tr> <td>Inferred</td> <td>287.7</td> <td>6.7</td> <td>1.72</td> <td>2.32</td> <td>18</td> <td>3</td> <td>17.2</td> <td>8.7</td> <td>7.5</td> <td>22.7</td> <td>2.9</td> <td>0.5</td> </tr> <tr> <td colspan="2">Grand Total</td> <td>628.7</td> <td>18.3</td> <td>1.73</td> <td>2.92</td> <td>18</td> <td>3</td> <td>20.2</td> <td>9.6</td> <td>8.2</td> <td>24.1</td> <td>3.3</td> <td>0.6</td> </tr> </tbody> </table> <table border="1"> <thead> <tr> <th>Area</th> <th>Resource Category</th> <th>Material (Mt)</th> <th>THM (%)</th> <th>In Situ THM (Mt)</th> <th>GeO₂ (%)</th> <th>Dy₂O₃ (%)</th> <th>Er₂O₃ (%)</th> <th>BaO (%)</th> <th>Gd₂O₃ (%)</th> <th>La₂O₃ (%)</th> <th>Nd₂O₃ (%)</th> <th>Pr₂O₃ (%)</th> <th>Sm₂O₃ (%)</th> <th>Tb₂O₃ (%)</th> <th>Tm₂O₃ (%)</th> <th>Y₂O₃ (%)</th> <th>Yb₂O₃ (%)</th> <th>TREO (%)</th> </tr> </thead> <tbody> <tr> <td>Area 1</td> <td>Measured</td> <td>30.7</td> <td>5.72</td> <td>1.76</td> <td>0.96</td> <td>0.07</td> <td>0.05</td> <td>0.004</td> <td>0.06</td> <td>0.48</td> <td>0.38</td> <td>0.11</td> <td>0.07</td> <td>0.012</td> <td>0.008</td> <td>0.47</td> <td>0.05</td> <td>2.72</td> </tr> <tr> <td>Area 1,2W, 3, 4</td> <td>Indicated</td> <td>310.3</td> <td>3.19</td> <td>9.89</td> <td>0.74</td> <td>0.09</td> <td>0.06</td> <td>0.005</td> <td>0.10</td> <td>0.75</td> <td>0.67</td> <td>0.19</td> <td>0.12</td> <td>0.017</td> <td>0.009</td> <td>0.59</td> <td>0.05</td> <td>3.38</td> </tr> <tr> <td>Area 3</td> <td>Inferred</td> <td>287.7</td> <td>2.32</td> <td>6.68</td> <td>0.67</td> <td>0.08</td> <td>0.05</td> <td>0.005</td> <td>0.09</td> <td>0.73</td> <td>0.65</td> <td>0.18</td> <td>0.12</td> <td>0.015</td> <td>0.008</td> <td>0.56</td> <td>0.05</td> <td>3.21</td> </tr> <tr> <td colspan="2">Grand Total</td> <td>628.7</td> <td>2.92</td> <td>18.33</td> <td>0.72</td> <td>0.09</td> <td>0.05</td> <td>0.005</td> <td>0.09</td> <td>0.73</td> <td>0.64</td> <td>0.18</td> <td>0.12</td> <td>0.016</td> <td>0.008</td> <td>0.57</td> <td>0.05</td> <td>3.27</td> </tr> </tbody> </table> <ul style="list-style-type: none"> Additional Mineral Resources have been estimated for the Goschen Project, however are due for upgrade and as such have not been subject to Ore Reserve calculation. The following tables comprise the Company Ore Reserves for the Goschen Project as at March 2022. This represents the Ore Reserve of the unconstrained project (Global Reserve). 	Area	Resource Category	Material (Mt)	In situ THM (kt)	Density (g/cm ³)	THM (%)	Slimes (%)	OS (%)	Zircon (%)	Rutile (%)	LX (%)	Ilmenite (%)	Monsazite (%)	Xenotime (%)	Area 1	Measured	30.7	1.8	1.76	5.72	15	5	29.9	10.8	9.0	24.7	4.3	0.8	Indicated	62.2	1.4	1.72	2.31	18	2	26.6	11.5	9.2	25.0	4.6	0.9	Total	92.9	3.2	1.73	3.44	17	3	27.7	11.2	9.1	24.9	4.5	0.8	Area 2 West	Indicated	26.0	0.7	1.72	2.80	20	8	22.0	16.0	12.0	25.0	3.0	1.0	Total	26.0	0.7	1.72	2.80	20	8	22.0	16.0	12.0	25.0	3.0	1.0	Area 3	Indicated	204.1	6.9	1.73	3.38	19	3	19.2	9.0	8.0	25.0	3.2	0.6	Inferred	287.7	6.7	1.72	2.32	18	3	17.2	8.7	7.5	22.7	2.9	0.5	Total	491.8	13.6	1.73	2.76	18	3	18.2	8.7	7.7	23.9	3.0	0.6	Area 4	Indicated	18.0	0.8	1.74	4.60	20	5	19.0	11.0	10.0	24.0	3.0	1.0	Total	18.0	0.8	1.74	4.60	20	5	19.0	11.0	10.0	24.0	3.0	1.0	Totals	Measured	30.7	1.8	1.76	5.72	15	5	29.9	10.8	9.0	24.7	4.3	0.8	Indicated	310.3	9.8	1.73	3.19	19	3	20.5	10.0	8.6	24.9	3.4	0.7	Inferred	287.7	6.7	1.72	2.32	18	3	17.2	8.7	7.5	22.7	2.9	0.5	Grand Total		628.7	18.3	1.73	2.92	18	3	20.2	9.6	8.2	24.1	3.3	0.6	Area	Resource Category	Material (Mt)	THM (%)	In Situ THM (Mt)	GeO ₂ (%)	Dy ₂ O ₃ (%)	Er ₂ O ₃ (%)	BaO (%)	Gd ₂ O ₃ (%)	La ₂ O ₃ (%)	Nd ₂ O ₃ (%)	Pr ₂ O ₃ (%)	Sm ₂ O ₃ (%)	Tb ₂ O ₃ (%)	Tm ₂ O ₃ (%)	Y ₂ O ₃ (%)	Yb ₂ O ₃ (%)	TREO (%)	Area 1	Measured	30.7	5.72	1.76	0.96	0.07	0.05	0.004	0.06	0.48	0.38	0.11	0.07	0.012	0.008	0.47	0.05	2.72	Area 1,2W, 3, 4	Indicated	310.3	3.19	9.89	0.74	0.09	0.06	0.005	0.10	0.75	0.67	0.19	0.12	0.017	0.009	0.59	0.05	3.38	Area 3	Inferred	287.7	2.32	6.68	0.67	0.08	0.05	0.005	0.09	0.73	0.65	0.18	0.12	0.015	0.008	0.56	0.05	3.21	Grand Total		628.7	2.92	18.33	0.72	0.09	0.05	0.005	0.09	0.73	0.64	0.18	0.12	0.016	0.008	0.57	0.05	3.27
Area	Resource Category	Material (Mt)	In situ THM (kt)	Density (g/cm ³)	THM (%)	Slimes (%)	OS (%)	Zircon (%)	Rutile (%)	LX (%)	Ilmenite (%)	Monsazite (%)	Xenotime (%)																																																																																																																																																																																																																																																																																														
Area 1	Measured	30.7	1.8	1.76	5.72	15	5	29.9	10.8	9.0	24.7	4.3	0.8																																																																																																																																																																																																																																																																																														
	Indicated	62.2	1.4	1.72	2.31	18	2	26.6	11.5	9.2	25.0	4.6	0.9																																																																																																																																																																																																																																																																																														
	Total	92.9	3.2	1.73	3.44	17	3	27.7	11.2	9.1	24.9	4.5	0.8																																																																																																																																																																																																																																																																																														
Area 2 West	Indicated	26.0	0.7	1.72	2.80	20	8	22.0	16.0	12.0	25.0	3.0	1.0																																																																																																																																																																																																																																																																																														
	Total	26.0	0.7	1.72	2.80	20	8	22.0	16.0	12.0	25.0	3.0	1.0																																																																																																																																																																																																																																																																																														
Area 3	Indicated	204.1	6.9	1.73	3.38	19	3	19.2	9.0	8.0	25.0	3.2	0.6																																																																																																																																																																																																																																																																																														
	Inferred	287.7	6.7	1.72	2.32	18	3	17.2	8.7	7.5	22.7	2.9	0.5																																																																																																																																																																																																																																																																																														
	Total	491.8	13.6	1.73	2.76	18	3	18.2	8.7	7.7	23.9	3.0	0.6																																																																																																																																																																																																																																																																																														
Area 4	Indicated	18.0	0.8	1.74	4.60	20	5	19.0	11.0	10.0	24.0	3.0	1.0																																																																																																																																																																																																																																																																																														
	Total	18.0	0.8	1.74	4.60	20	5	19.0	11.0	10.0	24.0	3.0	1.0																																																																																																																																																																																																																																																																																														
Totals	Measured	30.7	1.8	1.76	5.72	15	5	29.9	10.8	9.0	24.7	4.3	0.8																																																																																																																																																																																																																																																																																														
	Indicated	310.3	9.8	1.73	3.19	19	3	20.5	10.0	8.6	24.9	3.4	0.7																																																																																																																																																																																																																																																																																														
	Inferred	287.7	6.7	1.72	2.32	18	3	17.2	8.7	7.5	22.7	2.9	0.5																																																																																																																																																																																																																																																																																														
Grand Total		628.7	18.3	1.73	2.92	18	3	20.2	9.6	8.2	24.1	3.3	0.6																																																																																																																																																																																																																																																																																														
Area	Resource Category	Material (Mt)	THM (%)	In Situ THM (Mt)	GeO ₂ (%)	Dy ₂ O ₃ (%)	Er ₂ O ₃ (%)	BaO (%)	Gd ₂ O ₃ (%)	La ₂ O ₃ (%)	Nd ₂ O ₃ (%)	Pr ₂ O ₃ (%)	Sm ₂ O ₃ (%)	Tb ₂ O ₃ (%)	Tm ₂ O ₃ (%)	Y ₂ O ₃ (%)	Yb ₂ O ₃ (%)	TREO (%)																																																																																																																																																																																																																																																																																									
Area 1	Measured	30.7	5.72	1.76	0.96	0.07	0.05	0.004	0.06	0.48	0.38	0.11	0.07	0.012	0.008	0.47	0.05	2.72																																																																																																																																																																																																																																																																																									
Area 1,2W, 3, 4	Indicated	310.3	3.19	9.89	0.74	0.09	0.06	0.005	0.10	0.75	0.67	0.19	0.12	0.017	0.009	0.59	0.05	3.38																																																																																																																																																																																																																																																																																									
Area 3	Inferred	287.7	2.32	6.68	0.67	0.08	0.05	0.005	0.09	0.73	0.65	0.18	0.12	0.015	0.008	0.56	0.05	3.21																																																																																																																																																																																																																																																																																									
Grand Total		628.7	2.92	18.33	0.72	0.09	0.05	0.005	0.09	0.73	0.64	0.18	0.12	0.016	0.008	0.57	0.05	3.27																																																																																																																																																																																																																																																																																									

Criteria	JORC Code Explanation	Commentary																																																																																																																																																																																																																																																																																									
		<table border="1"> <thead> <tr> <th>Area</th> <th>Date</th> <th>Class.</th> <th>Ore (Mt)</th> <th>THM%</th> <th>ZIR%</th> <th>RUT%</th> <th>LX%</th> <th>ILM%</th> <th>MON%</th> <th>XEN%</th> </tr> </thead> <tbody> <tr> <td>1</td> <td>Mar-22</td> <td>Proved</td> <td>24.5</td> <td>5.4</td> <td>29.9</td> <td>10.8</td> <td>9</td> <td>24.7</td> <td>4.3</td> <td>0.8</td> </tr> <tr> <td>1</td> <td>Mar-22</td> <td>Probable</td> <td>14.6</td> <td>3.2</td> <td>29.2</td> <td>11.7</td> <td>9.2</td> <td>25.5</td> <td>4.5</td> <td>0.9</td> </tr> <tr> <td>3</td> <td>Mar-22</td> <td>Probable</td> <td>159.6</td> <td>3.5</td> <td>20.3</td> <td>9.4</td> <td>8.1</td> <td>25.8</td> <td>3.4</td> <td>0.6</td> </tr> <tr> <td colspan="3" rowspan="2">Total</td> <td>Proved</td> <td>24.5</td> <td>5.4</td> <td>29.9</td> <td>10.8</td> <td>9</td> <td>24.7</td> <td>4.3</td> <td>0.8</td> </tr> <tr> <td>Probable</td> <td>174.2</td> <td>3.5</td> <td>21</td> <td>9.6</td> <td>8.2</td> <td>25.8</td> <td>3.5</td> <td>0.6</td> </tr> <tr> <td colspan="3">Grand Total</td> <td></td> <td>198.7</td> <td>3.7</td> <td>21.7</td> <td>9.7</td> <td>8.2</td> <td>25.7</td> <td>3.5</td> <td>0.6</td> </tr> </tbody> </table> <table border="1"> <thead> <tr> <th>Area</th> <th>Class.</th> <th>Ore (Mt)</th> <th>THM %</th> <th>CeO₂ %</th> <th>Dy₂O₃ %</th> <th>Er₂O₃ %</th> <th>Eu₂O₃ %</th> <th>Gd₂O₃ %</th> <th>La₂O₃ %</th> <th>Nd₂O₃ %</th> <th>Pf₆O₁₁ %</th> <th>Sm₂O₃ %</th> <th>Tb₄O₇ %</th> <th>Tm₂O₃ %</th> <th>Y₂O₃ %</th> <th>Yb₂O₃ %</th> <th>TREO %</th> </tr> </thead> <tbody> <tr> <td>1</td> <td>Prov</td> <td>24.5</td> <td>5.4</td> <td>0.960</td> <td>0.070</td> <td>0.050</td> <td>0.004</td> <td>0.060</td> <td>0.480</td> <td>0.380</td> <td>0.110</td> <td>0.070</td> <td>0.012</td> <td>0.008</td> <td>0.470</td> <td>0.050</td> <td>2.720</td> </tr> <tr> <td>1</td> <td>Prob</td> <td>14.6</td> <td>3.2</td> <td>0.971</td> <td>0.067</td> <td>0.047</td> <td>0.004</td> <td>0.060</td> <td>0.468</td> <td>0.400</td> <td>0.108</td> <td>0.072</td> <td>0.011</td> <td>0.007</td> <td>0.458</td> <td>0.050</td> <td>2.721</td> </tr> <tr> <td>3</td> <td>Prob</td> <td>159.6</td> <td>3.5</td> <td>0.805</td> <td>0.057</td> <td>0.039</td> <td>0.003</td> <td>0.056</td> <td>0.378</td> <td>0.339</td> <td>0.093</td> <td>0.064</td> <td>0.009</td> <td>0.006</td> <td>0.386</td> <td>0.040</td> <td>2.297</td> </tr> <tr> <td colspan="2" rowspan="2">Total</td> <td>Prov</td> <td>24.5</td> <td>5.4</td> <td>0.960</td> <td>0.070</td> <td>0.050</td> <td>0.004</td> <td>0.060</td> <td>0.480</td> <td>0.380</td> <td>0.110</td> <td>0.070</td> <td>0.012</td> <td>0.008</td> <td>0.470</td> <td>0.050</td> <td>2.720</td> </tr> <tr> <td>Prob</td> <td>174.2</td> <td>3.5</td> <td>0.817</td> <td>0.058</td> <td>0.039</td> <td>0.003</td> <td>0.056</td> <td>0.385</td> <td>0.344</td> <td>0.094</td> <td>0.065</td> <td>0.009</td> <td>0.006</td> <td>0.391</td> <td>0.041</td> <td>2.328</td> </tr> <tr> <td colspan="2">Grand Total</td> <td></td> <td>198.7</td> <td>3.7</td> <td>0.844</td> <td>0.060</td> <td>0.041</td> <td>0.003</td> <td>0.057</td> <td>0.402</td> <td>0.351</td> <td>0.097</td> <td>0.066</td> <td>0.010</td> <td>0.006</td> <td>0.406</td> <td>0.043</td> <td>2.401</td> </tr> </tbody> </table> <ul style="list-style-type: none"> The Global Reserve is due for an update in H2 CY2023 following an update to Mineral Resources. The following tables comprise the Area 1 and 3 Ore Reserves as defined by the terms of the DFS Refresh for the Goschen Project. This Ore Reserve represents a subset of the above Global Ore Reserves and only cover the area over which VHM has sought mining approvals as of March 2023 (DFS Refresh Reserve). <table border="1"> <thead> <tr> <th>Area</th> <th>Date</th> <th>Class.</th> <th>Ore (Mt)</th> <th>THM%</th> <th>ZIR%</th> <th>RUT%</th> <th>LX%</th> <th>ILM%</th> <th>MON%</th> <th>XEN%</th> </tr> </thead> <tbody> <tr> <td>1</td> <td>Mar-23</td> <td>Proved</td> <td>25.5</td> <td>5.6</td> <td>29.6</td> <td>10.8</td> <td>9.1</td> <td>24.7</td> <td>4.3</td> <td>0.8</td> </tr> <tr> <td>1</td> <td>Mar-23</td> <td>Probable</td> <td>7.6</td> <td>2.2</td> <td>27.6</td> <td>12.7</td> <td>10.5</td> <td>25.9</td> <td>4.3</td> <td>0.9</td> </tr> <tr> <td>3</td> <td>Mar-23</td> <td>Probable</td> <td>65.7</td> <td>3.6</td> <td>19.7</td> <td>9.1</td> <td>7.9</td> <td>25.3</td> <td>3.3</td> <td>0.6</td> </tr> <tr> <td colspan="3" rowspan="2">Total</td> <td>Proved</td> <td>25.5</td> <td>5.6</td> <td>29.6</td> <td>10.8</td> <td>9.1</td> <td>24.7</td> <td>4.3</td> <td>0.8</td> </tr> <tr> <td>Probable</td> <td>73.3</td> <td>3.4</td> <td>20.2</td> <td>9.3</td> <td>8.1</td> <td>25.4</td> <td>3.4</td> <td>0.6</td> </tr> <tr> <td colspan="3">Grand Total</td> <td></td> <td>98.8</td> <td>4</td> <td>23.6</td> <td>9.9</td> <td>8.5</td> <td>25.1</td> <td>3.7</td> <td>0.7</td> </tr> </tbody> </table>	Area	Date	Class.	Ore (Mt)	THM%	ZIR%	RUT%	LX%	ILM%	MON%	XEN%	1	Mar-22	Proved	24.5	5.4	29.9	10.8	9	24.7	4.3	0.8	1	Mar-22	Probable	14.6	3.2	29.2	11.7	9.2	25.5	4.5	0.9	3	Mar-22	Probable	159.6	3.5	20.3	9.4	8.1	25.8	3.4	0.6	Total			Proved	24.5	5.4	29.9	10.8	9	24.7	4.3	0.8	Probable	174.2	3.5	21	9.6	8.2	25.8	3.5	0.6	Grand Total				198.7	3.7	21.7	9.7	8.2	25.7	3.5	0.6	Area	Class.	Ore (Mt)	THM %	CeO ₂ %	Dy ₂ O ₃ %	Er ₂ O ₃ %	Eu ₂ O ₃ %	Gd ₂ O ₃ %	La ₂ O ₃ %	Nd ₂ O ₃ %	Pf ₆ O ₁₁ %	Sm ₂ O ₃ %	Tb ₄ O ₇ %	Tm ₂ O ₃ %	Y ₂ O ₃ %	Yb ₂ O ₃ %	TREO %	1	Prov	24.5	5.4	0.960	0.070	0.050	0.004	0.060	0.480	0.380	0.110	0.070	0.012	0.008	0.470	0.050	2.720	1	Prob	14.6	3.2	0.971	0.067	0.047	0.004	0.060	0.468	0.400	0.108	0.072	0.011	0.007	0.458	0.050	2.721	3	Prob	159.6	3.5	0.805	0.057	0.039	0.003	0.056	0.378	0.339	0.093	0.064	0.009	0.006	0.386	0.040	2.297	Total		Prov	24.5	5.4	0.960	0.070	0.050	0.004	0.060	0.480	0.380	0.110	0.070	0.012	0.008	0.470	0.050	2.720	Prob	174.2	3.5	0.817	0.058	0.039	0.003	0.056	0.385	0.344	0.094	0.065	0.009	0.006	0.391	0.041	2.328	Grand Total			198.7	3.7	0.844	0.060	0.041	0.003	0.057	0.402	0.351	0.097	0.066	0.010	0.006	0.406	0.043	2.401	Area	Date	Class.	Ore (Mt)	THM%	ZIR%	RUT%	LX%	ILM%	MON%	XEN%	1	Mar-23	Proved	25.5	5.6	29.6	10.8	9.1	24.7	4.3	0.8	1	Mar-23	Probable	7.6	2.2	27.6	12.7	10.5	25.9	4.3	0.9	3	Mar-23	Probable	65.7	3.6	19.7	9.1	7.9	25.3	3.3	0.6	Total			Proved	25.5	5.6	29.6	10.8	9.1	24.7	4.3	0.8	Probable	73.3	3.4	20.2	9.3	8.1	25.4	3.4	0.6	Grand Total				98.8	4	23.6	9.9	8.5	25.1	3.7	0.7
Area	Date	Class.	Ore (Mt)	THM%	ZIR%	RUT%	LX%	ILM%	MON%	XEN%																																																																																																																																																																																																																																																																																	
1	Mar-22	Proved	24.5	5.4	29.9	10.8	9	24.7	4.3	0.8																																																																																																																																																																																																																																																																																	
1	Mar-22	Probable	14.6	3.2	29.2	11.7	9.2	25.5	4.5	0.9																																																																																																																																																																																																																																																																																	
3	Mar-22	Probable	159.6	3.5	20.3	9.4	8.1	25.8	3.4	0.6																																																																																																																																																																																																																																																																																	
Total			Proved	24.5	5.4	29.9	10.8	9	24.7	4.3	0.8																																																																																																																																																																																																																																																																																
			Probable	174.2	3.5	21	9.6	8.2	25.8	3.5	0.6																																																																																																																																																																																																																																																																																
Grand Total				198.7	3.7	21.7	9.7	8.2	25.7	3.5	0.6																																																																																																																																																																																																																																																																																
Area	Class.	Ore (Mt)	THM %	CeO ₂ %	Dy ₂ O ₃ %	Er ₂ O ₃ %	Eu ₂ O ₃ %	Gd ₂ O ₃ %	La ₂ O ₃ %	Nd ₂ O ₃ %	Pf ₆ O ₁₁ %	Sm ₂ O ₃ %	Tb ₄ O ₇ %	Tm ₂ O ₃ %	Y ₂ O ₃ %	Yb ₂ O ₃ %	TREO %																																																																																																																																																																																																																																																																										
1	Prov	24.5	5.4	0.960	0.070	0.050	0.004	0.060	0.480	0.380	0.110	0.070	0.012	0.008	0.470	0.050	2.720																																																																																																																																																																																																																																																																										
1	Prob	14.6	3.2	0.971	0.067	0.047	0.004	0.060	0.468	0.400	0.108	0.072	0.011	0.007	0.458	0.050	2.721																																																																																																																																																																																																																																																																										
3	Prob	159.6	3.5	0.805	0.057	0.039	0.003	0.056	0.378	0.339	0.093	0.064	0.009	0.006	0.386	0.040	2.297																																																																																																																																																																																																																																																																										
Total		Prov	24.5	5.4	0.960	0.070	0.050	0.004	0.060	0.480	0.380	0.110	0.070	0.012	0.008	0.470	0.050	2.720																																																																																																																																																																																																																																																																									
		Prob	174.2	3.5	0.817	0.058	0.039	0.003	0.056	0.385	0.344	0.094	0.065	0.009	0.006	0.391	0.041	2.328																																																																																																																																																																																																																																																																									
Grand Total			198.7	3.7	0.844	0.060	0.041	0.003	0.057	0.402	0.351	0.097	0.066	0.010	0.006	0.406	0.043	2.401																																																																																																																																																																																																																																																																									
Area	Date	Class.	Ore (Mt)	THM%	ZIR%	RUT%	LX%	ILM%	MON%	XEN%																																																																																																																																																																																																																																																																																	
1	Mar-23	Proved	25.5	5.6	29.6	10.8	9.1	24.7	4.3	0.8																																																																																																																																																																																																																																																																																	
1	Mar-23	Probable	7.6	2.2	27.6	12.7	10.5	25.9	4.3	0.9																																																																																																																																																																																																																																																																																	
3	Mar-23	Probable	65.7	3.6	19.7	9.1	7.9	25.3	3.3	0.6																																																																																																																																																																																																																																																																																	
Total			Proved	25.5	5.6	29.6	10.8	9.1	24.7	4.3	0.8																																																																																																																																																																																																																																																																																
			Probable	73.3	3.4	20.2	9.3	8.1	25.4	3.4	0.6																																																																																																																																																																																																																																																																																
Grand Total				98.8	4	23.6	9.9	8.5	25.1	3.7	0.7																																																																																																																																																																																																																																																																																

Criteria	JORC Code Explanation	Commentary																																																																																																																													
		<table border="1"> <thead> <tr> <th>Area</th> <th>Class.</th> <th>Ore (Mt)</th> <th>THM %</th> <th>CeO₂ %</th> <th>Dy₂O₃ %</th> <th>Er₂O₃ %</th> <th>Eu₂O₃ %</th> <th>Gd₂O₃ %</th> <th>La₂O₃ %</th> <th>Nd₂O₃ %</th> <th>Pr₆O₁₁ %</th> <th>Sm₂O₃ %</th> <th>Tb₄O₇ %</th> <th>Tm₂O₃ %</th> <th>Y₂O₃ %</th> <th>Yb₂O₃ %</th> <th>TREO %</th> </tr> </thead> <tbody> <tr> <td>1</td> <td>Prov</td> <td>25.5</td> <td>5.6</td> <td>0.960</td> <td>0.070</td> <td>0.050</td> <td>0.004</td> <td>0.060</td> <td>0.480</td> <td>0.380</td> <td>0.110</td> <td>0.070</td> <td>0.012</td> <td>0.008</td> <td>0.470</td> <td>0.050</td> <td>2.720</td> </tr> <tr> <td>1</td> <td>Prob</td> <td>7.6</td> <td>2.2</td> <td>0.957</td> <td>0.065</td> <td>0.045</td> <td>0.003</td> <td>0.059</td> <td>0.454</td> <td>0.398</td> <td>0.104</td> <td>0.071</td> <td>0.012</td> <td>0.007</td> <td>0.456</td> <td>0.050</td> <td>2.682</td> </tr> <tr> <td>3</td> <td>Prob</td> <td>65.7</td> <td>3.6</td> <td>0.795</td> <td>0.056</td> <td>0.038</td> <td>0.003</td> <td>0.055</td> <td>0.373</td> <td>0.335</td> <td>0.091</td> <td>0.063</td> <td>0.009</td> <td>0.006</td> <td>0.383</td> <td>0.039</td> <td>2.271</td> </tr> <tr> <td rowspan="2">Total</td> <td>Prov</td> <td>25.5</td> <td>5.6</td> <td>0.960</td> <td>0.070</td> <td>0.050</td> <td>0.004</td> <td>0.060</td> <td>0.480</td> <td>0.380</td> <td>0.110</td> <td>0.070</td> <td>0.012</td> <td>0.008</td> <td>0.470</td> <td>0.050</td> <td>2.720</td> </tr> <tr> <td>Prob</td> <td>73.3</td> <td>3.4</td> <td>0.806</td> <td>0.056</td> <td>0.039</td> <td>0.003</td> <td>0.055</td> <td>0.379</td> <td>0.339</td> <td>0.092</td> <td>0.064</td> <td>0.009</td> <td>0.006</td> <td>0.388</td> <td>0.040</td> <td>2.298</td> </tr> <tr> <td colspan="2">Grand Total</td> <td>98.8</td> <td>4.0</td> <td>0.862</td> <td>0.061</td> <td>0.043</td> <td>0.003</td> <td>0.057</td> <td>0.415</td> <td>0.354</td> <td>0.099</td> <td>0.066</td> <td>0.010</td> <td>0.007</td> <td>0.417</td> <td>0.044</td> <td>2.451</td> </tr> </tbody> </table> <p>Notes:</p> <ul style="list-style-type: none"> The Proved DFS Refresh Reserves stated in the March 2023 table are larger than that stated in the Global Reserve table due to a reduction in the required offset between the pit crest and vegetation to be conserved around the pit. Figures in Tables may not sum due to rounding. The Mineral Resources are reported as wholly inclusive of the Ore Reserves Despite changes to the inputs used to generate the DFS Ore Reserves between March 2022 and March 2023, the DFS Ore Reserve is unchanged largely due to physical limitations relating to the approvals process and project footprint. The Resource model was regularised to have uniform cells of 25 m x 25 m x 1 m in size, the process of regularising created a diluted model suitable for use in mine planning and Ore Reserve estimation with no further mining dilution or mining recovery applicable. 	Area	Class.	Ore (Mt)	THM %	CeO ₂ %	Dy ₂ O ₃ %	Er ₂ O ₃ %	Eu ₂ O ₃ %	Gd ₂ O ₃ %	La ₂ O ₃ %	Nd ₂ O ₃ %	Pr ₆ O ₁₁ %	Sm ₂ O ₃ %	Tb ₄ O ₇ %	Tm ₂ O ₃ %	Y ₂ O ₃ %	Yb ₂ O ₃ %	TREO %	1	Prov	25.5	5.6	0.960	0.070	0.050	0.004	0.060	0.480	0.380	0.110	0.070	0.012	0.008	0.470	0.050	2.720	1	Prob	7.6	2.2	0.957	0.065	0.045	0.003	0.059	0.454	0.398	0.104	0.071	0.012	0.007	0.456	0.050	2.682	3	Prob	65.7	3.6	0.795	0.056	0.038	0.003	0.055	0.373	0.335	0.091	0.063	0.009	0.006	0.383	0.039	2.271	Total	Prov	25.5	5.6	0.960	0.070	0.050	0.004	0.060	0.480	0.380	0.110	0.070	0.012	0.008	0.470	0.050	2.720	Prob	73.3	3.4	0.806	0.056	0.039	0.003	0.055	0.379	0.339	0.092	0.064	0.009	0.006	0.388	0.040	2.298	Grand Total		98.8	4.0	0.862	0.061	0.043	0.003	0.057	0.415	0.354	0.099	0.066	0.010	0.007	0.417	0.044	2.451
Area	Class.	Ore (Mt)	THM %	CeO ₂ %	Dy ₂ O ₃ %	Er ₂ O ₃ %	Eu ₂ O ₃ %	Gd ₂ O ₃ %	La ₂ O ₃ %	Nd ₂ O ₃ %	Pr ₆ O ₁₁ %	Sm ₂ O ₃ %	Tb ₄ O ₇ %	Tm ₂ O ₃ %	Y ₂ O ₃ %	Yb ₂ O ₃ %	TREO %																																																																																																														
1	Prov	25.5	5.6	0.960	0.070	0.050	0.004	0.060	0.480	0.380	0.110	0.070	0.012	0.008	0.470	0.050	2.720																																																																																																														
1	Prob	7.6	2.2	0.957	0.065	0.045	0.003	0.059	0.454	0.398	0.104	0.071	0.012	0.007	0.456	0.050	2.682																																																																																																														
3	Prob	65.7	3.6	0.795	0.056	0.038	0.003	0.055	0.373	0.335	0.091	0.063	0.009	0.006	0.383	0.039	2.271																																																																																																														
Total	Prov	25.5	5.6	0.960	0.070	0.050	0.004	0.060	0.480	0.380	0.110	0.070	0.012	0.008	0.470	0.050	2.720																																																																																																														
	Prob	73.3	3.4	0.806	0.056	0.039	0.003	0.055	0.379	0.339	0.092	0.064	0.009	0.006	0.388	0.040	2.298																																																																																																														
Grand Total		98.8	4.0	0.862	0.061	0.043	0.003	0.057	0.415	0.354	0.099	0.066	0.010	0.007	0.417	0.044	2.451																																																																																																														
Site visits	<ul style="list-style-type: none"> A site visit is to be carried out by the competent person(s) signing off on the Ore Reserve. 	<ul style="list-style-type: none"> Mr Anthony Keers carried out a site visit in August 2019. 																																																																																																																													
Study status	<ul style="list-style-type: none"> The type and level of study undertaken to enable Mineral Resources to be converted to Ore Reserves. The Code requires that a study to at least Pre-Feasibility Study level has been undertaken to convert Mineral Resources to Ore Reserves. Such studies will have been carried out and will have determined a mine plan that is technically achievable and economically viable, and that material Modifying Factors have been considered. 	<ul style="list-style-type: none"> This work was undertaken at Definitive Feasibility Study level, the Ore Reserve portion of which was carried out on supplied Mineral Resource models. The process flow sheet including the MUP, FPP, WCP and rare earth flotation circuit (Phase 1) was used as the basis for OPEX, process recovery and product sell price inputs which informed the Ore Reserve estimation process. The outcomes of the Hydromet Engineering (Phase 1A) have not been used to inform the Ore Reserve estimation process. This will be further assessed as part of ongoing Engineering studies as part of the Hydromet Program in 2023. 																																																																																																																													

Criteria	JORC Code Explanation	Commentary
		<ul style="list-style-type: none"> Any material classified as an Inferred Mineral Resource was not included in the Ore Reserve calculations.
Cut-off parameters	<ul style="list-style-type: none"> The basis of the cut-off grade(s) or quality parameters applied. 	<ul style="list-style-type: none"> A single cut-off grade (using thm or tvhm) was found to not accurately reflect the optimisation results, as such a calculation was undertaken to classify each block as ore or waste. The ore/waste classification was performed in three steps: calculating the revenue of each block, calculating the processing cost of each block and ultimately the cash flow of each block. If the block revenue was greater than the processing cost, the block was treated as ore, otherwise the block was treated as waste.
Mining factors or assumptions	<ul style="list-style-type: none"> The method and assumptions used as reported in the Pre-Feasibility or Feasibility Study to convert the Mineral Resource to an Ore Reserve (i.e. either by application of appropriate factors by optimisation or by preliminary or detailed design). The choice, nature and appropriateness of the selected mining method(s) and other mining parameters including associated design issues such as pre-strip, access, etc. The assumptions made regarding geotechnical parameters (e.g. pit slopes, stope sizes, etc), grade control and pre-production drilling. The major assumptions made, and Mineral Resource model used for pit and stope optimisation (if appropriate). The mining dilution factors used. The mining recovery factors used. Any minimum mining widths used. The manner in which Inferred Mineral Resources are utilised in mining studies and the sensitivity of the outcome to their inclusion. The infrastructure requirements of the selected mining methods. 	<ul style="list-style-type: none"> Pit optimisations were completed using Whittle software. Complete extraction of ore within pit designs is planned. Exclusion Zones have been determined to minimise the impact of operations on the environment and community. Potentially economic material within the exclusion zone may be included in future Ore Reserve estimates. Ore will be trucked to an MUP ROM on the surface close to the mining face. The MUP will be relocated at as required to optimise truck haulage and slurry pumping. Waste material will be used to create in-pit bunds to contain tailings or dump to fill mined voids. No drill and blast operations will be required, cross ripping of cemented sand horizons by dozers may be required. Mining will be undertaken in as a strip/block-mining operation. Each block will be approximately 500m x 150m. An overall wall angle of 30° has been proposed based on completed geotechnical studies. A batter angle of 40° was applied to the uppermost bench (in the topsoil / clayey-sand material), with a 6 m wide berm created at the base of the clayey material or 10 m below surface, whichever produces the lower berm level (i.e. a maximum depth of 10 m). Beneath this berm, a single slope was designed to the pit floor; the slope angle used for this bench was either 34° in Area 1 East (overall pit depth generally <= 32 m) and 32° in Area 1 West and Area 3 (overall pit depth generally > 32 m).

Criteria	JORC Code Explanation	Commentary
		<ul style="list-style-type: none"> • Mining recovery and dilution were not applied following the block model regularisation process. • Inferred material was treated as waste during optimisations, designs and scheduling. • External temporary waste dumps and tailings storage facilities will be required during early operations until sufficient mined voids are available to commence backfilling.
Metallurgical factors or assumptions	<ul style="list-style-type: none"> • The metallurgical process proposed and the appropriateness of that process to the style of mineralisation. • Whether the metallurgical process is well-tested technology or novel in nature. • The nature, amount and representativeness of metallurgical test work undertaken, the nature of the metallurgical domaining applied and the corresponding metallurgical recovery factors applied. • Any assumptions or allowances made for deleterious elements. • The existence of any bulk sample or pilot scale test work and the degree to which such samples are considered representative of the orebody as a whole. • For minerals that are defined by a specification, has the ore reserve estimation been based on the appropriate mineralogy to meet the specifications? 	<ul style="list-style-type: none"> • Ore material will undergo processing through a Mining Unit Plant (MUP), Feed Preparation Plant (FPP), Wet Concentrator Plant (WCP) and Rare Earth Flotation circuit. • An additional rare earth hydromet process was included in the financial analysis, the economic impact of this circuit is noticeably better than without, however has not been included in the pit optimisation, pit design or Ore Reserve estimation as they were not generated to a DFS level of confidence. • Industry standard metallurgical processes and equipment are proposed for the Project. • A representative bulk sample taken from the mining area was used for testwork. • The bulk sample was processed through a pilot scale testwork laboratory.
Environmental	<ul style="list-style-type: none"> • The status of studies of potential environmental impacts of the mining and processing operation. Details of waste rock characterisation and the consideration of potential sites, status of design options considered and, where applicable, the status of approvals for process residue storage and waste dumps should be reported. 	<ul style="list-style-type: none"> • The DFS Refresh Reserve is constrained within an area over which an Environmental Effects Statement (EES) has been submitted to gain regulatory approval to commence operations. • Some saleable products generated through processing may have elevated levels of radioactivity, these products will be taken off site following appropriate regulations. • Waste material remaining on site are not considered to pose any environmental risk. • Ongoing consultation between the company and the State of Victoria is required to determine land clearing allowances/requirements.
Infrastructure	<ul style="list-style-type: none"> • The existence of appropriate infrastructure: availability of land for plant development, power, water, transportation (particularly for bulk commodities), labour, accommodation; 	<ul style="list-style-type: none"> • The Project is located in an agricultural area of northern Victoria and is well serviced by road, rail, power, and water, with nearby communities able to provide labour and accommodation. • Additional infrastructure or upgrades may be required for the Project.

Criteria	JORC Code Explanation	Commentary																																																																		
	or the ease with which the infrastructure can be provided, or accessed.	<ul style="list-style-type: none"> The Company has engaged with landowners as required to secure access for drilling, environmental surveys, and ultimately project footprints. 																																																																		
Costs	<ul style="list-style-type: none"> The derivation of, or assumptions made, regarding projected capital costs in the study. The methodology used to estimate operating costs. Allowances made for the content of deleterious elements. The derivation of assumptions made of metal or commodity price(s), for the principal minerals and co- products. The source of exchange rates used in the study. Derivation of transportation charges. The basis for forecasting or source of treatment and refining charges, penalties for failure to meet specification, etc. The allowances made for royalties payable, both Government and private. 	<ul style="list-style-type: none"> Capital costs for processing infrastructure was completed by Mineral Technologies Pty Ltd (MTPL) based on testwork undertaken by them for the Company. Non-process infrastructure capital costs were provided by TZMI based on existing, similar projects. Processing operating costs were estimated by MTPL based on testwork. Mining operating costs were sourced from mining contractors by way of a Request For Quotation. A long term exchange rate of US\$0.7:A\$1 was selected and provided by the Company, only commodity reference prices were provided in US\$, all capital and operating costs were estimated in A\$. The Company undertook a study to estimate freight and logistics costs for both land and sea transport. A state royalty of 2.75% of product revenue was applied to the Project. 																																																																		
Revenue factors	<ul style="list-style-type: none"> The derivation of, or assumptions made regarding revenue factors including head grade, metal or commodity price(s) exchange rates, transportation and treatment charges, penalties, net smelter returns, etc. The derivation of assumptions made of metal or commodity price(s), for the principal metals, minerals, and co-products. 	<ul style="list-style-type: none"> Adamas Intelligence (rare earths) and TZMI (zircon and titania minerals) completed independent market reviews and provided long term reference prices in real USD: <table border="1"> <thead> <tr> <th></th> <th>Unit</th> <th>2022</th> <th>2023</th> <th>2024</th> <th>2025</th> <th>2026</th> <th>2027</th> <th>2028</th> <th>2029</th> <th>2030</th> </tr> </thead> <tbody> <tr> <td>REMC</td> <td>USD/kg</td> <td>11.15</td> <td>11.04</td> <td>13.12</td> <td>15.93</td> <td>16.49</td> <td>16.34</td> <td>16.06</td> <td>16.54</td> <td>17.33</td> </tr> <tr> <td>Zircon</td> <td>USD/t</td> <td>1,877</td> <td>1,822</td> <td>1,625</td> <td>1,515</td> <td>1,531</td> <td>1,510</td> <td>1,483</td> <td>1,463</td> <td>1,418</td> </tr> <tr> <td>Rutile</td> <td>USD/t</td> <td>1,345</td> <td>1,424</td> <td>1,352</td> <td>1,417</td> <td>1,391</td> <td>1,314</td> <td>1,286</td> <td>1,274</td> <td>1,267</td> </tr> <tr> <td>Leucoxene</td> <td>USD/t</td> <td>249</td> <td>286</td> <td>289</td> <td>300</td> <td>307</td> <td>292</td> <td>287</td> <td>288</td> <td>294</td> </tr> <tr> <td>Ilmenite</td> <td>USD/t</td> <td>287</td> <td>300</td> <td>243</td> <td>229</td> <td>228</td> <td>228</td> <td>235</td> <td>238</td> <td>237</td> </tr> </tbody> </table> <ul style="list-style-type: none"> Commodity prices used for the study made allowances for transport costs and quality adjustments with input from TZMI regarding the quality of Goschen products. Pit optimisations used commodity prices based on the 2030 reference prices. 		Unit	2022	2023	2024	2025	2026	2027	2028	2029	2030	REMC	USD/kg	11.15	11.04	13.12	15.93	16.49	16.34	16.06	16.54	17.33	Zircon	USD/t	1,877	1,822	1,625	1,515	1,531	1,510	1,483	1,463	1,418	Rutile	USD/t	1,345	1,424	1,352	1,417	1,391	1,314	1,286	1,274	1,267	Leucoxene	USD/t	249	286	289	300	307	292	287	288	294	Ilmenite	USD/t	287	300	243	229	228	228	235	238	237
	Unit	2022	2023	2024	2025	2026	2027	2028	2029	2030																																																										
REMC	USD/kg	11.15	11.04	13.12	15.93	16.49	16.34	16.06	16.54	17.33																																																										
Zircon	USD/t	1,877	1,822	1,625	1,515	1,531	1,510	1,483	1,463	1,418																																																										
Rutile	USD/t	1,345	1,424	1,352	1,417	1,391	1,314	1,286	1,274	1,267																																																										
Leucoxene	USD/t	249	286	289	300	307	292	287	288	294																																																										
Ilmenite	USD/t	287	300	243	229	228	228	235	238	237																																																										
Market assessment	<ul style="list-style-type: none"> The demand, supply and stock situation for the particular commodity, consumption trends and factors likely to affect supply and demand into the future. A customer and competitor analysis along with the identification of likely market windows for the product. 	<ul style="list-style-type: none"> A market analysis was conducted by TZMI, which indicated that demand will outweigh supply in the short to medium term and should be at least neutral in the long term. TZMI has endorsed that all products generated from Goschen are potentially marketable subject to successful conclusion of final FS testwork and off take agreements. 																																																																		

Criteria	JORC Code Explanation	Commentary
	<ul style="list-style-type: none"> Price and volume forecasts and the basis for these forecasts. For industrial minerals the customer specification, testing and acceptance requirements prior to a supply contract. 	<ul style="list-style-type: none"> Preliminary discussions with customers have indicated that 100% of products from Goschen will be subject to off take agreements. Further product testing is scheduled to confirm product specifications and realised product prices.
Economic	<ul style="list-style-type: none"> The inputs to the economic analysis to produce the net present value (NPV) in the study, the source and confidence of these economic inputs including estimated inflation, discount rate, etc. NPV ranges and sensitivity to variations in the significant assumptions and inputs. 	<ul style="list-style-type: none"> A discount rate of 10% was applied to the optimisation works and financial analysis for this study. Inputs to the economic analysis include Modifying Factors as described above. Sensitivity studies were carried out. Standard linear deviations were observed for all tested variables.
Social	<ul style="list-style-type: none"> The status of agreements with key stakeholders and matters leading to social licence to operate. 	<ul style="list-style-type: none"> Substantial consultation with the community and regulatory agencies in relation to the Goschen Project has commenced, involving consultation activities with identified key stakeholders. Regular meetings have been held with a Technical Reference Group and a Stakeholder Reference Group.
Other	<ul style="list-style-type: none"> To the extent relevant, the impact of the following on the project and/or on the estimation and classification of the Ore Reserves: Any identified material naturally occurring risks. The status of material legal agreements and marketing arrangements. The status of governmental agreements and approvals critical to the viability of the project, such as mineral tenement status, and government and statutory approvals. There must be reasonable grounds to expect that all necessary Government approvals will be received within the timeframes anticipated in the Pre-Feasibility or Feasibility study. Highlight and discuss the materiality of any unresolved matter that is dependent on a third party on which extraction of the reserve is contingent. 	<ul style="list-style-type: none"> There are no known significant naturally occurring risks to the project. In January 2015, Exploration Licence (EL) 5520 was granted to VHM Exploration Pty Ltd for a period of five years. In January 2020, Retention Licence 6806 was granted to the Company for a period of seven years to replace the expired EL5520. The DFS Refresh Reserve is constrained within an area over which an Environmental Effects Statement (EES) has been submitted to gain regulatory approval to commence operations. Alterations to this EES, including material changes to the Reserve has the potential to significantly delay the approval process.
Classification	<ul style="list-style-type: none"> The basis for the classification of the Ore Reserves into varying confidence categories. 	<ul style="list-style-type: none"> Measured Resources have been converted to Proved Reserves within (3) paddocks over which VHM have land access agreements and to Probable Reserves outside these paddocks, Indicated Resources have been converted to Probable Reserves.

Criteria	JORC Code Explanation	Commentary
	<ul style="list-style-type: none"> Whether the result appropriately reflects the Competent Person's view of the deposit. The proportion of Probable Ore Reserves that have been derived from Measured Mineral Resources (if any). 	<ul style="list-style-type: none"> The estimated Ore Reserves are, in the opinion of the Competent Person, appropriate for this style of deposit.
Audits or reviews	<ul style="list-style-type: none"> The results of any audits or reviews of Ore Reserve estimates. 	<ul style="list-style-type: none"> Auralia Mining Consulting Pty Ltd has completed an internal review of the Ore Reserve estimate resulting from this study.
Discussion of relative accuracy/ confidence	<ul style="list-style-type: none"> Where appropriate a statement of the relative accuracy and confidence level in the Ore Reserve estimate using an approach or procedure deemed appropriate by the Competent Person. For example, the application of statistical or geostatistical procedures to quantify the relative accuracy of the reserve within stated confidence limits, or, if such an approach is not deemed appropriate, a qualitative discussion of the factors which could affect the relative accuracy and confidence of the estimate. The statement should specify whether it relates to global or local estimates, and, if local, state the relevant tonnages, which should be relevant to technical and economic evaluation. Documentation should include assumptions made and the procedures used. Accuracy and confidence discussions should extend to specific discussions of any applied Modifying Factors that may have a material impact on Ore Reserve viability, or for which there are remaining areas of uncertainty at the current study stage. It is recognised that this may not be possible or appropriate in all circumstances. These statements of relative accuracy and confidence of the estimate should be compared with production data, where available. 	<ul style="list-style-type: none"> The level of study carried out as part of the March 2023 Ore Reserve is to a Definitive-Feasibility Study level. The relative accuracy of the estimate is reflected in the reporting of the Ore Reserves as per the guidelines re: modifying factors, study levels and Competent Persons contained in the JORC 2012 Code. This statement relates to global estimates of tonnes and grade. Sensitivity studies were carried out. Standard linear deviations were observed. Globally, the project is susceptible to fluctuations in commodity price. Further product testing is scheduled to confirm product specifications, this information will be relayed to potential customers to determine realised product prices.